

CARPYEN

creativity concept

2008 / 2009



WWW.CARPYEN.COM

**LA LUZ DETERMINA MÁS
ELEMENTO, LA PERSONALIDAD
EL AMBIENTE.
LA ILUMINACIÓN REFLEJA
ESTADOS DE ÁNIMO, SUGIERE
PROVOCA CALMA O ACCIÓN,
INQUIETUD, ILUSIÓN, SENSUALIDAD,
CARÁCTER, PAZ.**

LIGHT DEFINES, MORE THAN ANY OTHER ELEMENT THE PERSONALITY OF WHOEVER LIVES IN THAT SPACE.

LIGHTING REFLECTS THE SPIRIT, CREATES A MOOD, SUGGESTS EMOTIONS, BRINGS CALM OR ACTION, SILENCE, CONCERN, ILLUSION, SENSUALITY, PEACE, MOVEMENT.

**QUE NINGÚN OTRO
DAD DE QUIEN HABITA**

**EL ESPÍRITU, PRODUCE
ERE SENTIMIENTOS,
SILENCIO, SERENIDAD,
SUALIDAD, MOVIMIENTO,**

DISEÑADORES



GABRIEL TEIXIDÓ



PASCUAL SALVADOR



JORDI MILÀ



JONATHAN DAIFUKU



TONI PALLEJÀ, PORCUATRO



NOVA +



L'ESTUDI

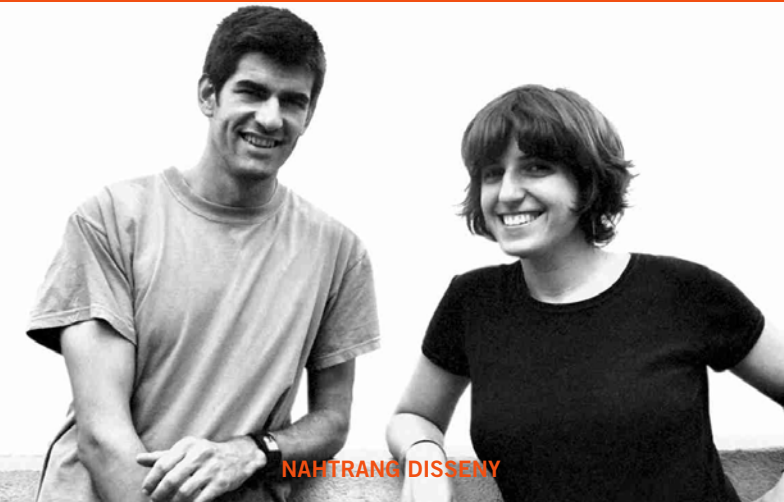

NAHTRANG DISSENY

HOTELS & RESTAURANTS

AC

Turino. Italy

ACCOR

- SOFITEL
Paris. France
- NOVOTEL
Leeds. UK

BARCELÓ

- BARCELÓ CABO DE GATA
Almería. Spain
- BARCELÓ AVENIDA
Bilbao. Spain

CATALONIA

- CATALONIA RIVIERA MAYA HOTEL
Puerto Aventuras. Mexico
- Barcelona. Spain

HILTON

- HILTON LA DEFENSE
Paris. France
- HILTON DUSSELDORF
Dusseldorf. Germany
- HILTON MUNICH
Munich. Germany
- HILTON NUREMBERG
Nuremberg. Germany
- HILTON DOUBLETREE
Moscow. Russia
- HILTON BARCELONA
Barcelona. Spain
- HILTON GENEVA
Geneva. Switzerland
- HILTON ZURICH
Zurich. Switzerland
- HILTON BIRMINGHAM
Birmingham. UK
- HILTON BRIGHTON
Brighton. UK
- HILTON LEICESTER
Leicester. UK
- HILTON WATDFORD
Watford. UK

HOLIDAY INN

Rugby, Portsmouth, Gloucester, Coventry, Oxford, Birmingham City and Reading. UK

HYATT

- HYATT REGENCY HOTEL
Coolum Queensland. Australia

INTERCONTINENTAL

- INTERCONTINENTAL SYDNEY HOTEL
Sydney. Australia
- INTERCONTINENTAL PARK LANE
London. UK

LE MÉRIDIEN

- New Delhi. India
- Minneapolis. USA
- Sunny Isles, Florida. USA

MELIÀ

- MELIÀ MAR HOTEL
Palma de Mallorca. Spain
- MELIÀ CONFORT HOTEL
Montevideo. Uruguay

NH

- Several in Barcelona, Cádiz, Madrid, etc.
Spain
- NH CONSTANZA HOTEL
Barcelona. Spain
- NH BARBIZON PALACE HOTEL
Amsterdam. The Netherlands

SANA

- SANA MALHOA HOTEL
Lisboa. Portugal
- SANA METROPOLITAN HOTEL
Lisboa. Portugal

SHERATON

SHERATON ON THE PARK
Sydney. Australia

Europe

MORE HOTEL
Dubrovnik. Croacia

FIAT RESTAURANT
Copenhagen. Denmark

CAYRE SA HOTEL
Paris. France

RAMADA HOTEL
Engelberg. Germany

ALEXANDER BEACH HOTEL
Alexandroupoli. Greece

FITZWILLIAM HOTEL
Dublin. Ireland

FELS POINT HOTEL
Trale. Ireland

RAMADA ORANMORE HOTEL
Galway. Ireland

BRITANNIA HOTEL
Trondheim. Norway

THON HOTEL GARDENMOEN
Jessheim. Norway

THON HOTEL GILDEVANGEN
Trondheim. Norway

THON HOTEL POLAR
Tromso. Norway

QUALITY HOTEL GRAND
Steinkjaer. Norway

DA TORRE HOTEL
Restelo. Portugal

INATEL HOTEL
Oeiras, Lisboa. Portugal

LUTECIA HOTEL
Lisboa. Portugal

QUINTA DA MARINHA HOTEL
Cascais. Portugal

THALASIA HOTEL
San Pedro del Pinatar, Alicante. Spain

TRAIÑA HOTEL
San Pedro del Pinatar, Alicante. Spain

CATALONIA RAMBLAS HOTEL
Barcelona. Spain

CITY IBEROSTAR HOTEL
Cádiz. Spain

CONDES DE BARCELONA HOTEL
Barcelona. Spain

DERBY HOTEL
Barcelona. Spain

DIPLOMATIC HOTEL
Barcelona. Spain

FONTANALS HOTEL
Barcelona. Spain

REY JUAN CARLOS I HOTEL
Barcelona. Spain

RIVOLI HOTEL
Barcelona. Spain

SKIPPER HOTEL
Barcelona. Spain

TARO BEACH HOTEL
Fuerteventura. Canary Island

AGUAMARINA HOTELS
Menorca. Spain

DEL ALBA HOTEL
Campo de golf Bonalba, Murcia. Spain

CLUB DE GOLF DE LAYOS HOTEL
Toledo. Spain

PARADOR NACIONAL EL SALER
Valencia. Spain

SAVOY HOTEL
Jönköping. Sweden

RIDDARGATAN HOTEL
Stockholm. Sweden

ADULA HOTEL
Fims. Switzerland

SCHWEIZERHOF HOTEL
Lenzerheide. Switzerland

SOFA HOTEL
Istanbul, Turkey

THREE SWANS HOTEL
Berkshire. UK

EXPRESS BY HOLIDAY INN
Bristol. UK

MOAT HOUSE HOTEL
Cambridge. UK

THE COUNTY HOTEL
Canterbury. UK

ANGEL HOUSE
Cardiff. UK

DART MARINA HOTEL
Dartmouth. UK

NORTON HOUSE
Edinburg. UK

CAESAR HOTEL. Derby Chain
London. UK

CAFE FISH
London. UK

CUMBERLAND HOTEL
London. UK

GREAT EASTERN HOTEL
Bishopsgate, London. UK

WINTHROP HALL HOTEL
Kent. UK

ALDERMAN FENWICK HOUSE
Newcastle upon Tyne. UK

DEVERE DUNSTAN HALL HOTEL
Norwich. UK

REVOLUTION BAR
Richmond, Surrey. UK

MOUNT COUNTRY HOUSE HOTEL
Rugby. UK

SOMERSTON HOTEL
Stratford-upon-Avon. UK

ROYAL YORK HOTEL
York. UK

America

FIESTA AMERICANA SANTA FE HOTEL
Mexico city. Mexico

FIESTA AMERICANA QUERÉTARO HOTEL
Querétaro. Mexico

MANDARIN ORIENTAL RIVIERA MAYA
Playa del Carmen. Mexico

LA SOURCE HOTEL&SPA. Great House Rest.
St. Georges, Grenada. West Indies

CAPITOL HOTEL
Florida. USA

HARD ROCK HOTEL&CASINO
Hollywood, Florida. USA

Asia

GINZA EAST RESIDENTIAL COMPLEX
Tokyo. Japan

MARINA MANDARIN HOTEL
Singapore

ROTANA HOTEL
Al Ain. United Arab Emirates

Oceania

REEF VIEW HOTEL
Hamilton Island Queensland. Australia

AIRPORTS VIP LOUNGES & TRAIN STATIONS

MUNICH AIRPORT
Germany

MADRID AND BARCELONA
Spain

MADRID-ZARAGOZA
Spain

PARK INN. HEATHROW AIRPORT
London. UK

MANCHESTER
UK

BANKS

ING
Throughout the country. Belgium

BANCO BILBAO VIZCAYA BBVA
Almost all branches. Spain

BANCO SABADELL ATLÁNTICO
Spain

LA CAIXA
Spain

RABO BANK
Eindhoven. The Netherlands

COMMERCE BANK
Throughout the country. USA

OFFICES BUILDINGS

SKYPE OFFICE
Tallinn. Estonia

MINISTRY OF FOREIGN AFFAIRS
Paris. France

CORPORATIVO SEE
Mexico city. Mexico

DIRECCIÓN GENERAL LA VISTA COUNTRY
CLUB PUEBLA. Puebla. Mexico

OFICINA LUÍS RIVERA
Mexico city. Mexico

NASTA
Moscow. Russia

NOVOSIBIRSK ENERGO OFFICE
Novosibirsk. Russia

UNITED EUROPE
Moscow. Russia

ICELAND FROZEN FOODS HEAD OFFICE
Chester. UK

MITTAL STEEL HEAD OFFICE
London. UK

PALL MALL COURT
Manchester. UK

ENTERTAINMENT & CULTURAL PLACES

METAL WORKERS MURIKKA INSTITUTE
Teisko. Finland

CITY HALL
Cologne. Germany

DUNKERRON WOODS HOLIDAY HOUSES
Kerry. Ireland

AUCKLAND CASINO
Auckland. New Zealand

ESTORIL CASINO
Estoril. Portugal

CLUB DE GOLF SANT CUGAT
Barcelona. Spain

CLUB DE GOLF FONTANALS
Girona. Spain

BIBLIOTECA UNIVERSIDAD REY JUAN CARLOS I
Fuenlabrada, Madrid. Spain

DAVID LLOYD TENNIS CLUB
Woking, Epsom, Oxford, Kingston, Finchley, Bromsgrove, Fulham. UK

LONDON BUSINESS SCHOOL
London. UK

SPA HILTON ROYAL PALACE
Jeddah. Saudi Arabia

OTHERS

BOOKSTORE BOG & IDE
Copenhagen. Denmark

DROUGSTORE MATAS HJØRRING
Hjørring. Denmark

PUNKT 1
Retail Shops in major cities. Denmark

KÄTKÄNKIISA PRIVATE HOLIDAY VILLA
Levi. Finland

VAASA CENTRAL HOSPITAL
Vaasa. Finland

DESARROLLO RESIDENCIAL LO ALTO
Mexico

CHARLOTTE RUSSE
Throughout the country. USA

HBO - TV CHAIN
Northridge, California. USA

AITAAITANAALADINA AURA
AURITACANDEL CITY
DOUGLAS GALAGALILEA
GILDA JAPAN MASTER
NAIROBINA OMINIRVANA
POPPY POPPY TEALIGHT
TEMA

SOBREMESAS, VELAS
TABLE LAMPS, CANDLES
TISCHLEUCHTEN, LEUCHTER

Sobremesa metálico con pantalla en algodón.

BOMBILLAS
1x100 W máx. (E-27)

ACABADOS
Cromo y plomo metalizado.

PANTALLAS
Blanca, beige y negra.

Metallic table lamp with cotton shade.

BULBS
1x100 W max. (E-27)

FINISHES
Chrome and metallic lead.

LAMPSHADES
White, beige and black.

Tischleuchte aus Metall mit Baumwoll-Schirm.

LAMPE
1x100 W max. (E-27)

OBERFLÄCHE
Chrom oder grau-metallic.

LAMPENSCHIRM
Weiß, beige oder schwarz.

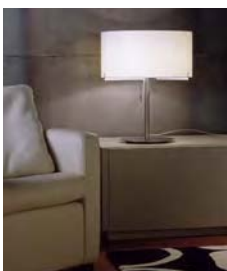

p.14



p.62



p.98

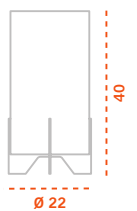



Sobremesa metálico con pantalla de tela en algodón. Interruptor en el mismo portalámparas.

BOMBILLAS
2x100 W máx. (E-27)

ACABADOS
Cromo y plomo metalizado.

PANTALLAS
Blanca, beige y negra.

Metallic table lamp with cotton shade. Switch on the same socket.

BULBS
2x100 W max. (E-27)

FINISHES
Chrome and metallic lead.

LAMPSHADES
White, beige and black.

Tischleuchte aus Metall mit Baumwoll-Schirm.

LAMPE
2x100 W max. (E-27)

OBERFLÄCHE
Chrom oder grau-metallic.

LAMPENSCHIRM
Weiß, beige oder schwarz.

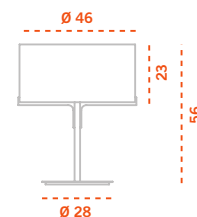



ALADINA

GABRIEL TEIXIDÓ

Lámpara articulada con uno o dos brazos. Accesorios: base mesa, pinza, soporte pared y pie.

BOMBILLAS
1x75 W máx. (G9) Halógena.

ACABADOS
Negro y plomo metalizado.

Articulated lamp with one or two arms. Accessories: table base, clamp, wall set and floor base.

BULBS
1x75 W max. (G9) Halogen.

FINISHES
Black and metallic lead.

Tischleuchte mit einem oder zwei dreh- und schwenkbaren Armen. Auch als Stehleuchte.

LAMPE
1x75 W max. (G9) Halogen.

OBERFLÄCHE
Schwarz oder grau-metallic.



ACCESORIOS ACCESSORIES ZUBEHÖR



Base sobremesa
Table base
Tischleuchte



Pinza
Clamp
Klemme



Soporte pared
Wall set
Wandleuchte



Pie
Floor base
Stehleuchte

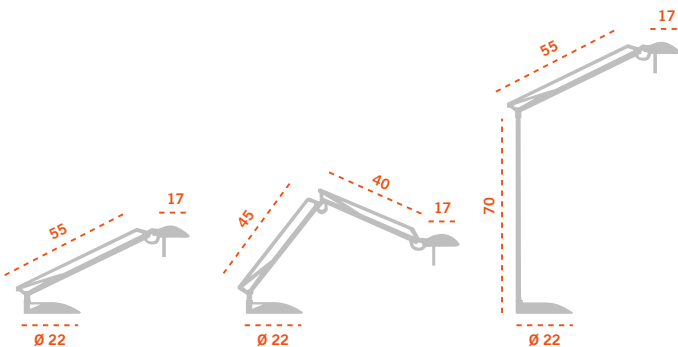







Sobremesa metálico con pantalla de tela en algodón. Interruptor en el mismo portalámparas.

BOMBILLAS
2x100 W máx. (E-27)

ACABADOS
Cromo y plomo metalizado.

PANTALLAS
- Lisa: blanca, beige y negra.
- Plisada: beige.

Table lamp with cotton fabric shade. Switch on the same socket.

BULBS
2x100 W max. (E-27)

FINISHES
Chrome and metallic lead.

LAMPSHADES
- Flat: white, beige and black.
- Pleated: beige.

Tischleuchte mit Baumwollschirm. Schalter in der Fassung integriert.

LAMPE
2x100 W max. (E-27)

OBERFLÄCHE
Chrom oder grau-metallic.

LAMPENSCHIRM
- Glatt: grau, beige oder schwarz.
- Plissiert: beige.

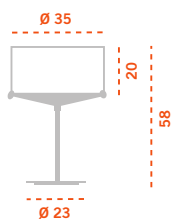

p. 68

p. 100

p. 130



Sobremesa metálico con pantalla de tela en algodón. Se fabrica en dos alturas.

BOMBILLAS
1x100 W máx. (E-27)

ACABADOS
Cromo y plomo metalizado.
Pantalla lisa: blanca, beige y negra.

Metallic table lamp with cotton fabric shade. Made in two heights.

BULBS
1x100 W max. (E-27)

FINISHES
Chrome and metallic lead.
Flat lampshade: white, beige and black.

Tischleuchte aus Metall mit Schirm aus Baumwolle. Erhältlich in zwei Größen.

LAMPE
1x100 W max. (E-27)

OBERFLÄCHE
Chrom oder grau-metallic.
Lampenschirm glatt: grau, beige oder schwarz.

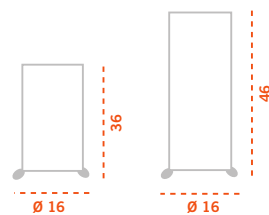



CANDEL

DAIFUKU DESIGNS



Es una lámpara autónoma para acompañar cenas en casa o restaurantes. Consta de dos piezas, un cuerpo de pírex soplado a mano y un cartucho estanco con aceite mineral inodoro de usar y tirar (40 horas de uso).

CARTUCHO

100 ml, aceite mineral.

The perfect lamp to create an intimate atmosphere for dinners at home or in restaurants. It deals with a genuine piece of art as it is handmade. The lamp is made up of one single compact pyrex glassblown body which contains a waterproof refill of mineral oil. The refill is totally odourless and easy to replace (40 hours lifespan).

REFILL

100 ml, mineral oil.

Ein Leuchter für stil- und stimmungsvolle Beleuchtung in Haus oder Garten aus in Handarbeit gefertigtem Pirex-Glas. Eine wasserdichte Kartusche mit geruchlos brennendem Mineralöl für eine Brenndauer von bis zu 40 Stunden gehört zum Lieferumfang.

KARTUSCHE

100 ml, Mineralöl.



Fabricación artesanal.
Hand-made.
In Handarbeit hergestellt.



Lámpara metálica orientable en todos los sentidos. Reflector giratorio 360°, incorpora interruptor. Versión sobremesa.

BOMBILLAS
1x75 W máx. (G9) Halógena.

ACABADOS
Cromo.

Metallic table lamp rotating in all directions. The reflector rotates 360° and incorporates an on-off switch.

BULBS
1x75 W max. (G9) Halogen.

FINISHES
Chrome.

Tischleuchte aus Metall, dreh- und schwenkbar in alle Richtungen, Reflektor 360° drehbar mit integriertem Schalter.

LAMPE
1x75 W max. (G9) Halogen.

OBERFLÄCHE
Chrom.





Lámpara metálica orientable en todos los sentidos. Reflector giratorio 360°, incorpora interruptor. Versión pinza (5 cm de apertura).

BOMBILLAS

1x75 W máx. (G9) Halógena.

ACABADOS

Cromo.

Metallic table lamp with clamp (5 cm opening) rotating in all directions. The reflector rotates 360° and incorporates an on-off switch.

BULBS

1x75 W max. (G9) Halogen.

FINISHES

Chrome.

Leuchte aus Metall mit Tischklemme (Klemmöffnung max. 5 cm), dreh- und schwenkbar in alle Richtungen, Reflektor um 360° drehbar mit intergriertem Schalter.

LAMPE

1x75 W max. (G9) Halogen.

OBERFLÄCHE

Chrom.

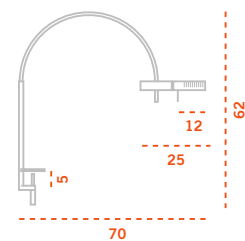
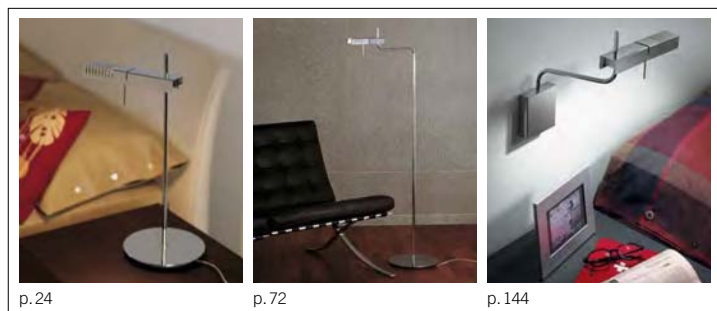



DOUGLAS

GABRIEL TEIXIDÓ



Lámpara articulada con uno o dos brazos. Accesorios: base mesa, pinza, soporte pared y pie.

BOMBILLAS
1x75 W máx. (E-27)

ACABADOS
Plomo metalizado.

Articulated lamp with one or two arms. Accessories: table base, clamp, wall set and floor base.

BULBS
1x75 W max. (E-27)

FINISHES
Metallic lead.

Tischleuchte mit einem oder zwei verstellbaren Armen. Auch als Steh- oder Klemmleuchte.

LAMPE
1x75 W max. (E-27)

OBERFLÄCHE
Grau-metallic.

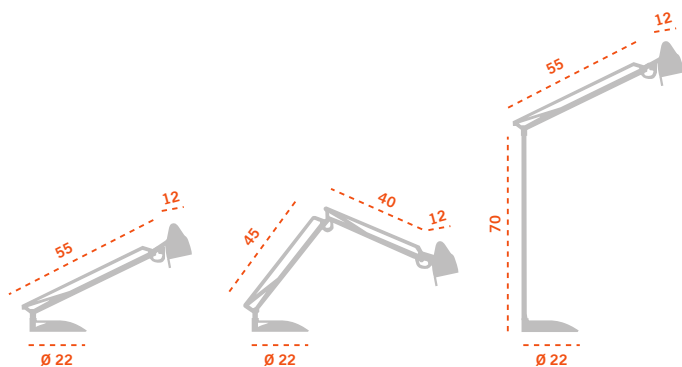

ACCESORIOS
ACCESSORIES
ZUBEHÖR



Sobremesa metálico incandescente.

BOMBILLAS
1x60 W máx. (E-14)

ACABADOS
Plomo metalizado y oro metalizado.

Metallic table lamp.

BULBS
1x60 W max. (E-14)

FINISHES
Metallic lead and metallic gold.

Tischleuchte aus Metall.

LAMPE
1x60 W max. (E-14)

OBERFLÄCHE
Grau- oder gold-metallic.





GALILEA

PASCUAL SALVADOR

Lámpara de sobremesa con luz directa y difusa. Se caracteriza por su brazo abatible y giratorio.

BOMBILLAS
1x60 W máx. (E-14)

ACABADOS
Titanio, plomo metalizado y oro metalizado.
Pantallas: blanco o beige en algodón.

Table lamp with direct and diffuse light. Adjustable and movable arm.

BULBS
1x60 W max. (E-14)

FINISHES
Metallic lead, metallic gold and titanium.
Shades: cotton fabric in white or beige.

Tischleuchte mit Baumwoll-Schirm auf dreh- und schwenkbarem Arm.

LAMPE
1x60 W max. (E-14)

OBERFLÄCHE
Titan, grau-metallic oder gold-metallic.
Schirme: Baumwolle glatt weiß oder beige.

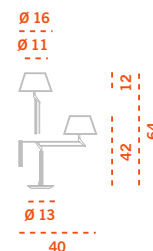



GALILEA

PASCUAL SALVADOR



Lámpara de sobremesa con luz directa y difusa. Se caracteriza por su brazo abatible y giratorio.

BOMBILLAS
1x100 W máx. (E-27)

ACABADOS
Titanio, plomo metalizado y oro metalizado.
Pantallas: blanco o beige en algodón.

Table lamp with direct and diffuse light. Adjustable and movable arm.

BULBS
1x100 W max. (E-27)

FINISHES
Metallic lead, metallic gold and titanium.
Shades: cotton fabric in white or beige.

Tischleuchte mit Baumwoll-Schirm auf dreh- und schwenkbarem Arm.

LAMPE
1x100 W max. (E-27)

OBERFLÄCHE
Titan, grau-metallic oder gold-metallic.
Schirme: Baumwolle glatt weiß oder beige.

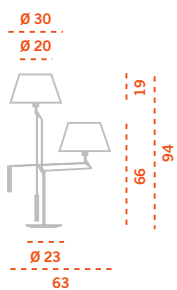



Lámparas de sobremesa metálicas con brazo en madera. Se fabrican en tres medidas.

BOMBILLAS

- Pequeña: 1x60 W máx. (E-14).
- Mediana y grande: 1x100 W máx. (E-27).

ACABADOS

Estructura: plomo metalizado.
Madera: wenge, cerezo y haya natural.
Pantallas: blanca y beige.

Metallic table lamps with wooden stem. Table lamp is available in three sizes.

BULBS

- Small: 1x60 W max. (E-14).
- Medium and large: 1x100 W max. (E-27).

FINISHES

Structure: metallic grey.
Wood: wenge, dark cherry and beech.
Shades: white and beige.

Tischleuchte aus Metall mit Holzapplikation. In drei Größen erhältlich.

LAMPE

- Klein: 1x60 W max. (E-14).
- Medium und groß: 1x100 W max. (E-27).

OBERFLÄCHE

Leuchte: grau-metallic.
Hölzer: Wenge, Kirsche oder Buche.
Schirme: weiß oder beige.

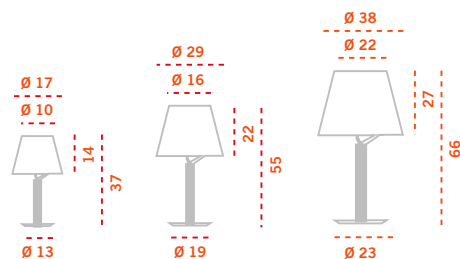

p. 162

Sobremesa metálica con pantalla de cristal opal. Se fabrica en dos medidas.

BOMBILLAS

- Grande: 1x100 W máx. (E-27)
- Pequeña: 1x60 W máx. (E-14)

ACABADOS

Cromo y plomo metalizado.

Opal glass table lamp with metallic frame. Available in two sizes.

BULBS

- Large: 1x100 W max. (E-27)
- Small: 1x60 W max. (E-14)

FINISHES

Chrome and metallic lead.

Tischleuchte aus Metall mit opal-weißem Glasschirm. In zwei Größen erhältlich.

LAMPE

- Groß: 1x100 W max. (E-27)
- Klein: 1x60 W max. (E-14)

OBERFLÄCHE

Chrom oder grau-metallic.

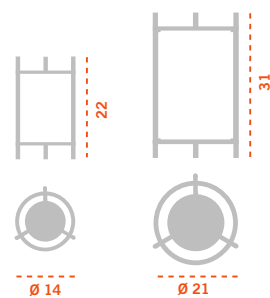



MASTER

GABRIEL TEIXIDÓ

Lámpara sobremesa halógena metálica con pantalla orientable.

BOMBILLAS
1x12V 50W máx. (M-32) Halógena.

ACABADOS
Negro y cromo.

Adjustable metallic table lamp.

BULBS
1x12V 50W max. (M-32) Halogen.

FINISHES
Black or chrome.

Tischleuchte mit verstellbarem Schirm.

LAMPE
1x12V 50W max. (M-32) Halogen.

OBERFLÄCHE
Schwarz oder chrom.





NAIROBI

GABRIEL TEIXIDÓ

Lámpara sobremesa metálica con pantalla en algodón, diseñada para espacios rectangulares o cuadrados.

BOMBILLAS
1x100 W máx. (E-27)

ACABADOS
Níquel mate.
Pantalla: blanca, beige y negra.

Metallic table lamp with cotton shade. Designed for square and rectangular spaces.

BULBS
1x100 W max. (E-27)

FINISHES
Matt nickel.
Shade: white, beige and black.

Tischleuchte mit Baumwollschirm.

LAMPE
1x100 W max. (E-27)

OBERFLÄCHE
Nickel matt.
Schirm: weiß, beige oder schwarz.

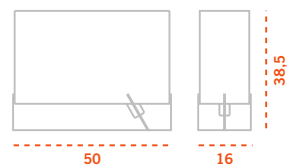



NAOMI

PORCUATRO



Lámparas de sobremesa metálicas.

BOMBILLAS

1x60 W máx. (E-14)

ACABADOS

Estructura negra.

Cable rojo o negro.

PANTALLA

Cintas: beige, roja y negra.

Metallic table lamps.

BULBS

1x60 W max. (E-14)

FINISHES

Black structure.

Cable in red or black.

LAMPSHADE

Bookbinding tape lampshade:

beige, red and black.

Tischleuchte aus Metall.

LAMPE

1x60 W max. (E-14)

OBERFLÄCHE

Schwarz strukturiert.

Kabel wahlweise rot oder schwarz.

LAMPENSCHIRM

Buchbindung-Stil: beige, rot oder schwarz.

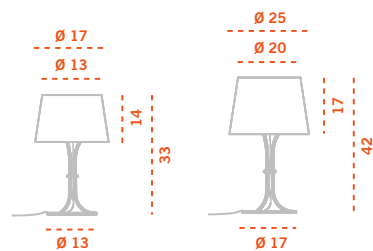

p. 46

p. 84

NAOMI

PORCUATRO



Lámpara sobremesa metálica.
Equipada con dimmer.

BOMBILLAS
1x150 W máx. (E-27)

ACABADOS
Estructura negra.
Cable rojo o negro.

PANTALLA
Cintas: beige, roja y negra.

Metallic table lamp. Equipped with
dimmer.

BULBS
1x150 W max. (E-27)

FINISHES
Black structure.
Cable in red or black.

LAMPSHADE
Bookbinding tape lampshade:
beige, red and black.

Tischleuchte aus Metall mit
integriertem Dimmer.

LAMPE
1x150 W max. (E-27)

OBERFLÄCHE
Schwarz strukturiert.
Kabel wahlweise rot oder schwarz.

LAMPENSCHIRM
Buchbindung-Stil: beige, rot oder
schwarz.

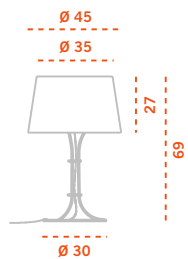

p. 44

p. 84

NIRVANA

GABRIEL TEIXIDÓ



Sobremesa metálico con pantalla en algodón, interruptor en el mismo portalámparas.

BOMBILLAS
1x150 W máx. (E-27)

ACABADOS
Níquel mate, marfil y negro.

PANTALLAS
- Exterior: blanca, beige y negra.
Interior: blanco.
- Exterior: negra.
Interior: naranja.

Metallic table lamp with cotton lampshade. Switch on the lampholder.

BULBS
1x150 W max. (E-27)

FINISHES
Matt nickel, ivory and black.

LAMPSHADES
- Outside: white, beige and black.
Inside: white.
- Outside: black.
Inside: orange.

Tischleuchte aus Metall mit Lampenschirm aus Baumwolle und Schnurschalter.

LAMPE
1x150 W max. (E-27)

OBERFLÄCHE
Nickel matt, elfenbein oder schwarz.

LAMPENSCHIRM
- Außen: weiss, beige oder schwarz.
Innen: weiss.
- Außen: schwarz.
Innen: orange.

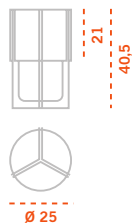

NIRVANA

GABRIEL TEIXIDÓ



Sobremesa metálico con pantalla en algodón, interruptor en el mismo portalámparas.

BOMBILLAS
1x150 W máx. (E-27)

ACABADOS
Níquel mate, marfil y negro.

PANTALLAS
- Exterior: blanca, beige y negra.
Interior: blanco.
- Exterior: negra.
Interior: naranja.

Metallic table lamp with cotton lampshade. Switch on the lampholder.

BULBS
1x150 W max. (E-27)

FINISHES
Matt nickel, ivory and black.

LAMPSHADES
- Outside: white, beige and black.
Inside: white.
- Outside: black.
Inside: orange.

Tischleuchte aus Metall mit Lampenschirm aus Baumwolle und Schnurschalter.

LAMPE
1x150 W max. (E-27)

OBERFLÄCHE
Nickel matt, elfenbein oder schwarz.

LAMPENSCHIRM
- Außen: weiss, beige oder schwarz.
Innen: weiss.
- Außen: schwarz.
Innen: orange.

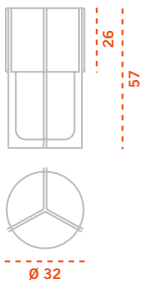

p. 48

p. 52

p. 86

NIRVANA

GABRIEL TEIXIDÓ



Sobremesa metálico con pantalla en algodón, interruptor en el mismo portalámparas.

BOMBILLAS
1x150 W máx. (E-27)

ACABADOS
Níquel mate, marfil y negro.

PANTALLAS
- Exterior: blanca, beige y negra.
Interior: blanco.
- Exterior: negra.
Interior: naranja.

Metallic table lamp with cotton lampshade. Switch on the lampholder.

BULBS
1x150 W max. (E-27)

FINISHES
Matt nickel, ivory and black.

LAMPSHADES
- Outside: white, beige and black.
Inside: white.
- Outside: black.
Inside: orange.

Tischleuchte aus Metall mit Lampenschirm aus Baumwolle und Schnurschalter.

LAMPE
1x150 W max. (E-27)

OBERFLÄCHE
Nickel matt, elfenbein oder schwarz.

LAMPENSCHIRM
- Außen: weiss, beige oder schwarz.
Innen: weiss.
- Außen: schwarz.
Innen: orange.

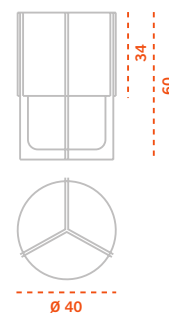





Es una lámpara autónoma para acompañar cenas en casa o restaurantes. Consta de un cuerpo en aluminio inyectado y un reflector en cristal pirex. Incorpora un cartucho estanco con aceite mineral inodoro de usar y tirar (40 horas de uso).

CARTUCHO

100 ml, aceite mineral.

ACABADOS

Cromo y negro antracita.

The perfect light to create an intimate atmosphere for dinners at home or in restaurants. Made of an injected aluminium body and pyrex glass reflector. The body contains a waterproof refill of mineral oil. The refill is totally odourless, disposable and easy to replace (40 hours lifespan).

REFILL

100 ml, mineral oil.

FINISHES

Chrome and anthracite black.

Ein Leuchter für stil- und stimmungsvolle Beleuchtung in Haus, Garten oder Restaurants aus Aluminium und Reflektor aus Pyrex-Glas. Eine wasserdichte Kartusche mit geruchlos brennendem Mineralöl für eine Brenndauer von bis zu 40 Stunden gehört zum Lieferumfang.

KARTUSCHE

100 ml, Mineralöl.

OBERFLÄCHE

Chrom oder schwarz anthrazit.





POPPY TEA LIGHT

DAIFUKU DESIGNS



Esta lámpara autónoma sólo se diferencia de su original Poppy en la carga. Ahora viene equipada con velas de cera, incorporando en su interior cinco velas de recambio. Consta de un cuerpo en aluminio inyectado y un reflector en cristal pirex.

ACABADOS

Cromo y negro antracita.

The only difference with the original Poppy is the refill which is substituted by wax candles. The body, injected in aluminium, contains five extra wax candles and the reflector is in pyrex glass.

FINISHES

Chrome and anthracite black.

Der einzige Unterschied zur originalen Poppy besteht, dass sie mit einem Teelicht bestückt wird. Das Aluminium-Druckgussgehäuse beinhaltet 5 Ersatz-Teelichter, der Reflektor besteht aus Pyrex-Glas.

OBERFLÄCHE

Chrom oder schwarz anthrazit.

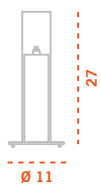



Sobremesa metálico. Lámpara orientable en todos los sentidos.

BOMBILLAS
1x12V 50W máx. (M-32) Halógena.

ACABADOS
Titanio, plomo metalizado, cromo y negro.

Metallic table lamp. Adjustable in all directions.

BULBS
1x12V 50W max. (M-32) Halogen.

FINISHES
Chrome, black, metallic lead and titanium.

Tischleuchte aus Metall. Dreh- und schwenkbar in alle Richtungen.

LAMPE
1x12V 50W max. (M-32) Halogen.

OBERFLÄCHE
Titan, grau-metallic, chrom oder schwarz.



p.90

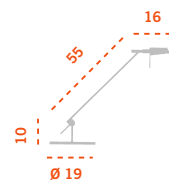



AITANAATENEAAUGUSTA
AURABARCINOCITY
CÓNICAGALAGALILEAMIA
MISSHANGAINAOMI
NIRVANASIGNORATEMA
TOTORATRIAHALÓGENA

PIES DE SUELO
FLOOR LAMPS
STEHLEUCHTEN

AITANA

GABRIEL TEIXIDÓ



Pie suelo metálico con pantalla de tela en algodón. Se fábrica en dos medidas. Interruptor en el mismo portalámparas.

BOMBILLAS

2x100 W máx. (E-27)

ACABADOS

Cromo y plomo metalizado.

PANTALLAS

Blanca, beige y negra.

Metallic floor lamp with cotton shade available in two sizes. Switch on the lampholder.

BULBS

2x100 W max. (E-27)

FINISHES

Chrome and metallic lead.

LAMPSHADES

White, beige and black.

Stehleuchte aus Metall mit Baumwoll-Schirm. In zwei Größen erhältlich.

LAMPE

2x100 W max. (E-27)

OBERFLÄCHE

Chrom oder grau-metallic.

LAMPENSCHIRM

Weiß, beige oder schwarz.

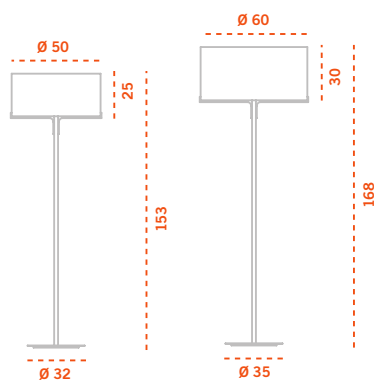

ATENEA

GABRIEL TEIXIDÓ



Pie suelo halógeno metálico,
equipado con dimmer.

BOMBILLAS
1x500 W máx. (R7S 118 mm)

ACABADOS
Cromo y plomo metalizado.

Metallic halogen floor lamp with
dimmer.

BULBS
1x500 W max. (R7S 118 mm)

FINISHES
Chrome and metallic lead.

Stehleuchte aus Metall mit Dimmer.

LAMPE
1x500 W max. (R7S 118 mm)

OBERFLÄCHE
Chrom oder grau-metallic.

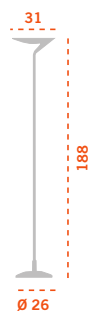



p.136

AUGUSTA

GABRIEL TEIXIDÓ

Pie suelo halógeno con dimmer.
Se caracteriza por tener su base y reflector en cristal mate. Todas las partes metálicas son de aluminio.

BOMBILLAS
1x250 W máx. (B-15d)

ACABADOS ANODIZADOS
Aluminio pulido y negro brillante.

Metallic halogen floor lamp with dimmer. The base and diffuser are in opaque glass.

BULBS
1x250 W max. (B-15d)

ANODIZED FINISHES
Polished aluminium and bright black.

Stehleuchte mit Dimmer.
Leuchtenfuß und Schirm aus mattiertem Glas. Alle Metallteile sind aus Aluminium.

LAMPE
1x250 W max. (B-15d)

OBERFLÄCHE
Poliertes Aluminium oder schwarz glänzend.

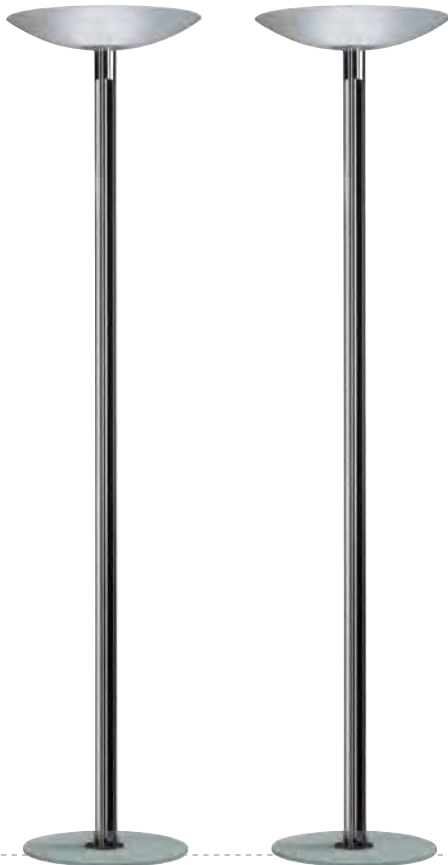



AURA

GABRIEL TEIXIDÓ



Pie suelo metálico con pantalla de tela en algodón, interruptor en el mismo portalámparas.

BOMBILLAS
2x100 W máx. (E-27)

ACABADOS
Cromo y plomo metalizado.

PANTALLAS
- Lisa: blanca, beige y negra.
- Plisada: beige.

Metallic floor lamp with cotton fabric shade. Switch on the lampholder.

BULBS
2x100 W max. (E-27)

FINISHES
Chrome and metallic lead.

LAMPSHADES
- Flat: white, beige and black.
- Pleated: beige.

Stehleuchte aus Metall mit Schirm aus Baumwolltwill. Mit Zugschalter an der Lampenfassung.

LAMPE
2x100 W max. (E-27)

OBERFLÄCHE
Chrom oder grau-metallic.

LAMPENSCHIRM
- Glatt: grau, beige oder schwarz.
- Plissiert: beige.

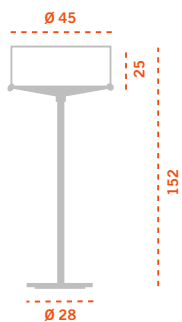

p. 18



p. 20



p. 100



p. 134

BARCINO

GABRIEL TEIXIDÓ

Pie suelo metálico halógeno.
El reflector gira 180° y está
equipado con dimmer.

BOMBILLAS
1x500 W máx. (R7S 118 mm)

ACABADOS
Cromo y plomo metalizado.

Metallic floor lamp. The reflector
rotates 180° and equipped with
dimmer.

BULBS
1x500 W max. (R7S 118 mm)

FINISHES
Chrome and metallic lead.

Stehleuchte aus Metall. Reflektor
drehbar 180°, dimmbar.

LAMPE
1x500 W max. (R7S 118 mm)

OBERFLÄCHE
Chrom oder grau-metallic.



p.136



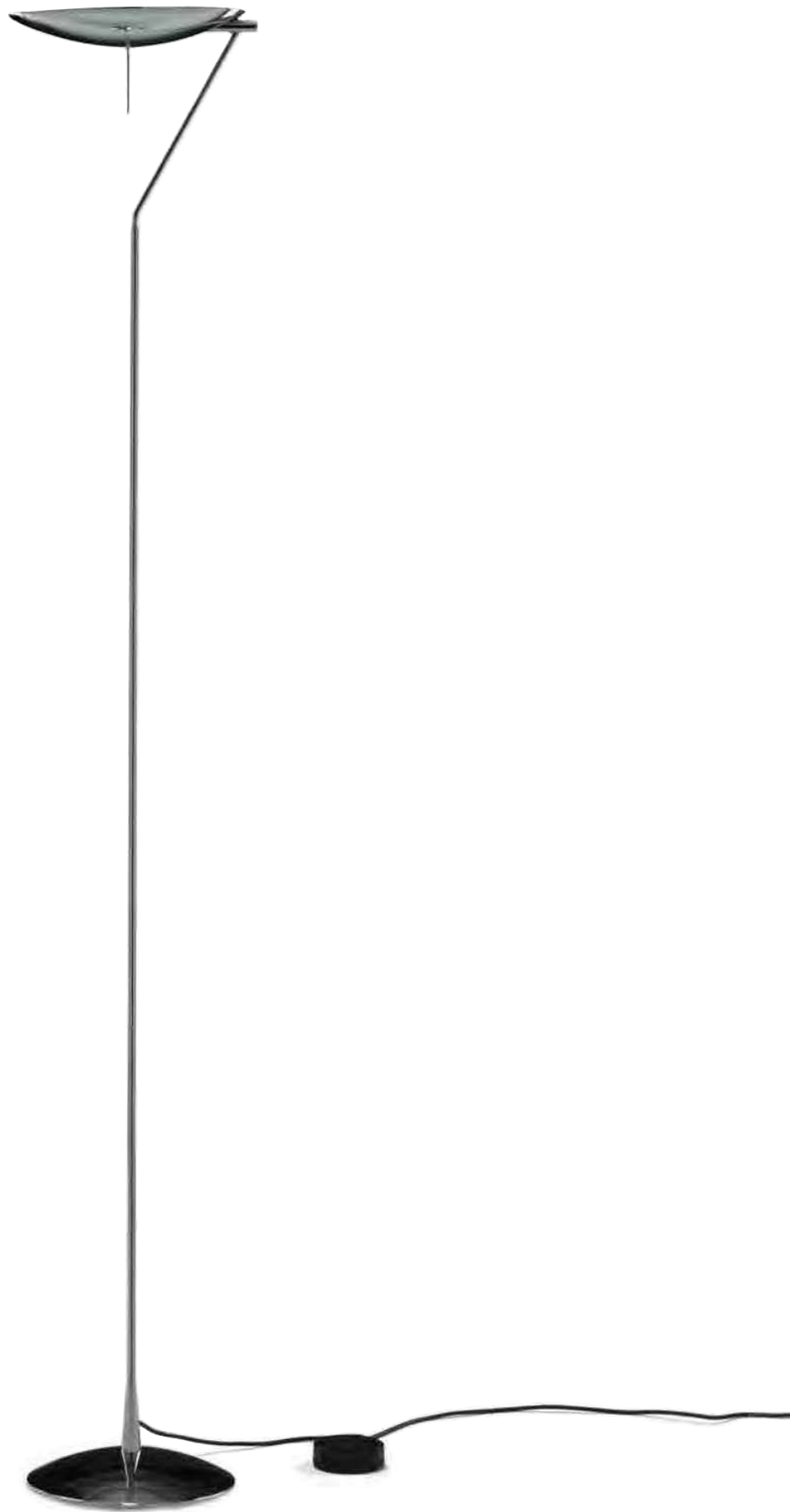

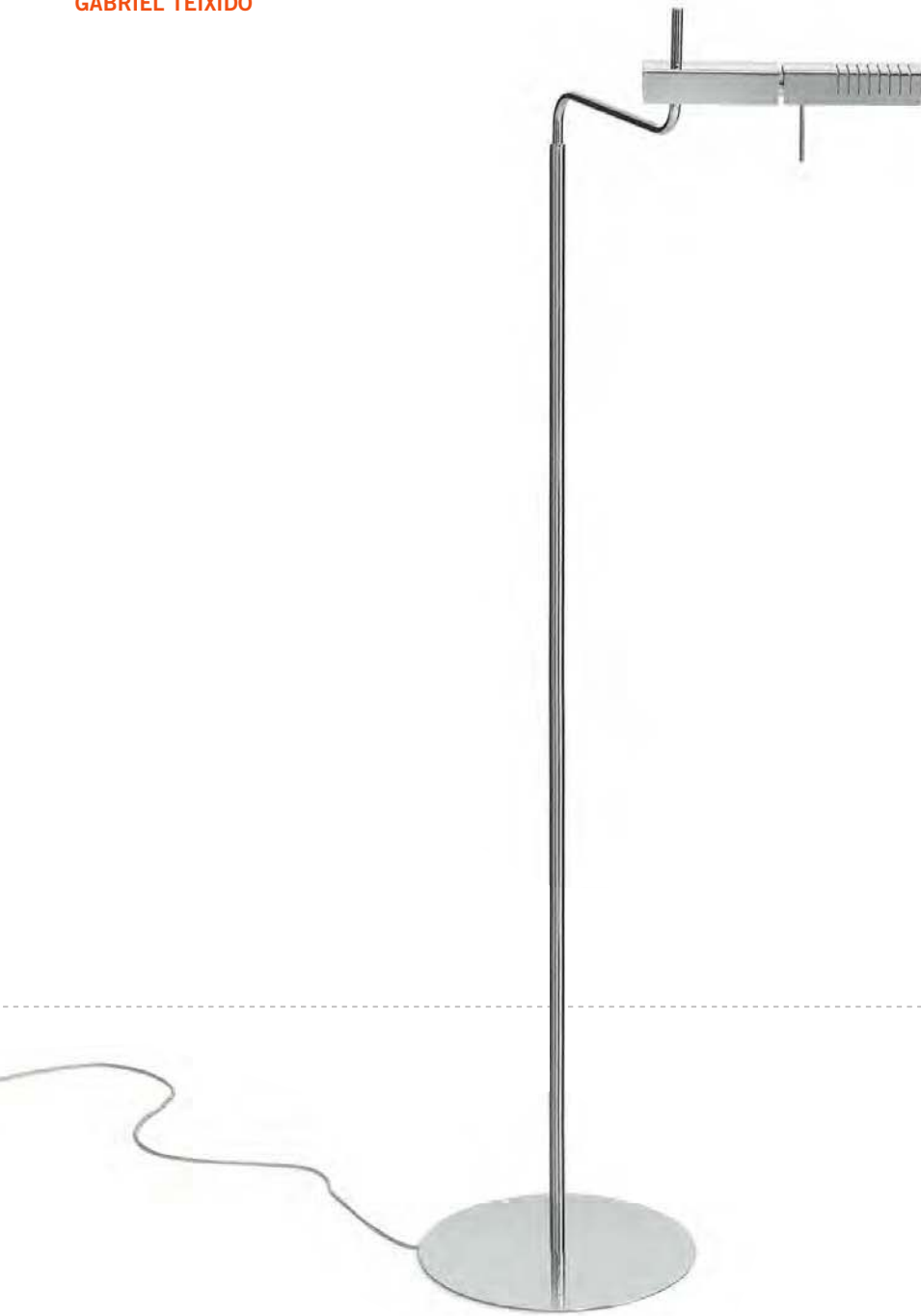

Pie suelo metálico. Orientable en todos los sentidos. Reflector giratorio 360°, incorpora interruptor.

BOMBILLAS
1x75 W máx. (G9) Halógena.

ACABADOS
Cromo.

Metallic floor lamp rotating in all directions. The reflector rotates 360° and incorporates an on-off switch.

BULBS
1x75 W max. (G9) Halogen.

FINISHES
Chrome.

Stehleuchte aus Metall. Dreh- und schwenkbar, Reflektor um 360° drehbar mit integrierterem Schalter.

LAMPE
1x75 W max. (G9) Halogen.

OBERFLÄCHE
Chrom.

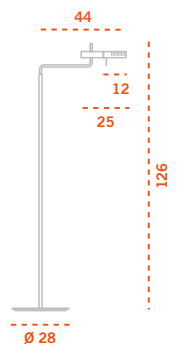



Pie suelo halógeno con cristal opal blanco equipado con dimmer.

BOMBILLAS
1x150 W máx. (B15d)

ACABADOS
Cromo y plomo metalizado.

Metallic halogen floor lamp with white opal diffuser. Equipped with dimmer.

BULBS
1x150 W max. (B15d)

FINISHES
Chrome and metallic lead.

Stehleuchte aus Metall mit weißem Opalglas und Dimmer.

LAMPE
1x150 W max. (B15d)

OBERFLÄCHE
Chrom oder grau-metallic.





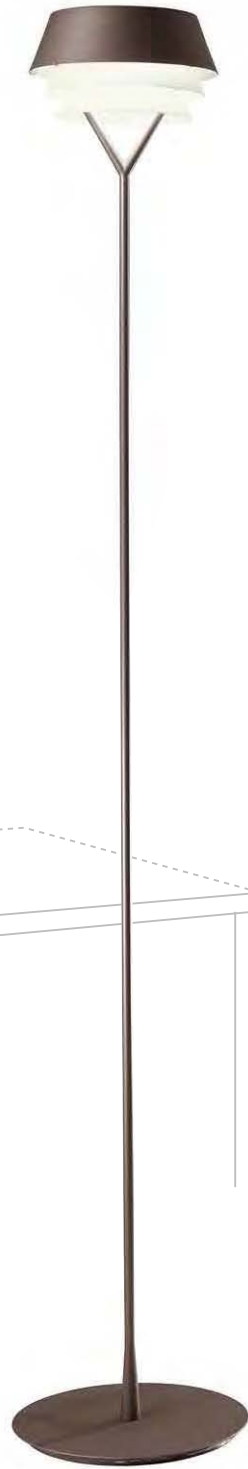

Pie de suelo metálico. Equipado con dimmer.

BOMBILLAS
1x300 W máx. (R7S 118 mm)
Halógeno.

ACABADOS
Plomo metalizado y oro metalizado.

Metallic floor lamp equipped with dimmer.

BULBS
1x300 W max. (R7S 118 mm)
Halogen.

FINISHES
Metallic lead and metallic gold.

Stehleuchte mit Schnurdimmer.

LAMPE
1x300 W max. (R7S 118 mm)
Halogen.

OBERFLÄCHE
Grau- oder gold-metalllic.

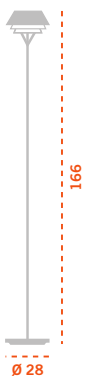



GALILEA

PASCUAL SALVADOR

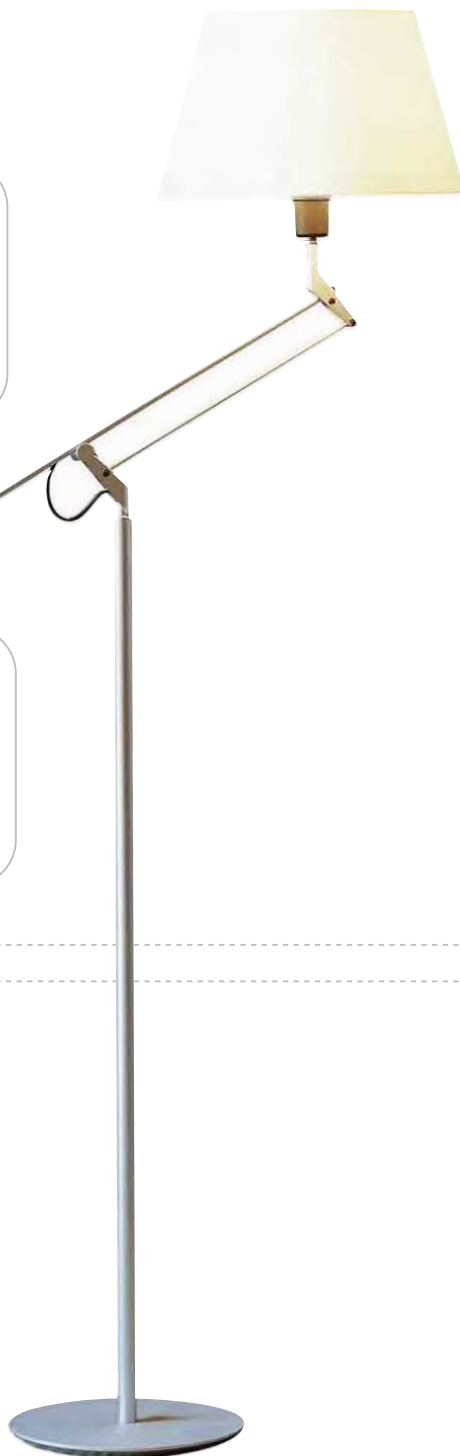
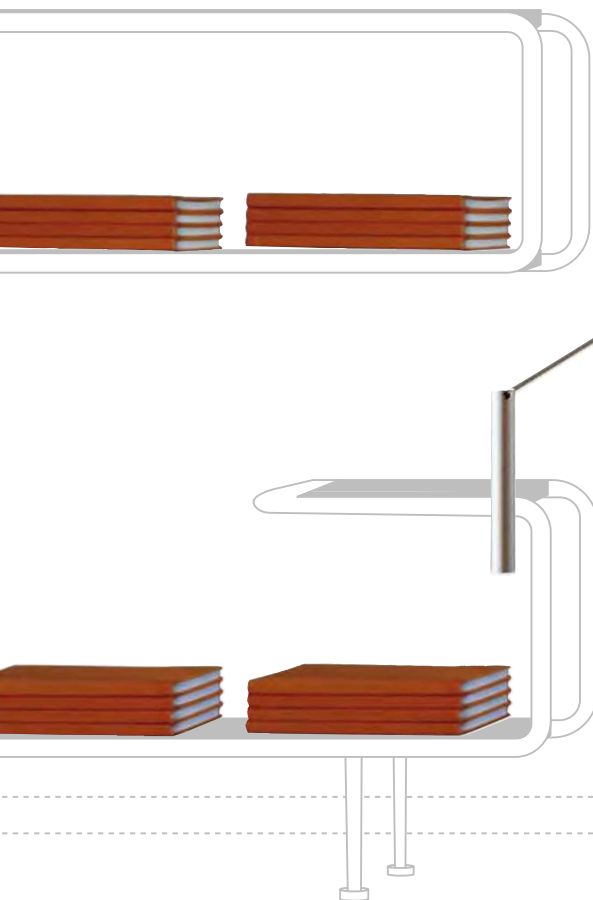

Lámpara de pie con luz directa y difusa. Se caracteriza por su brazo abatible y giratorio.

BOMBILLAS
1x100 W máx. (E-27)

ACABADOS
Titanio, plomo metalizado y oro metalizado.
Pantallas: blanco o beige en algodón.

Floor lamp with direct and diffuse light. Adjustable and movable arm.

BULBS
1x100 W max. (E-27)

FINISHES
Titanium, metallic lead and metallic gold.
Shades: cotton fabric in white or beige.

Stehleuchte aus Metall mit dreh- und schwenkbarem Arm.

LAMPE
1x100 W max. (E-27)

OBERFLÄCHE
Titan, grau-metallic oder gold-metallic.
Schirme: Baumwolle glatt weiß oder beige.



DELTA DE PLATA 1995
ADI-FAD

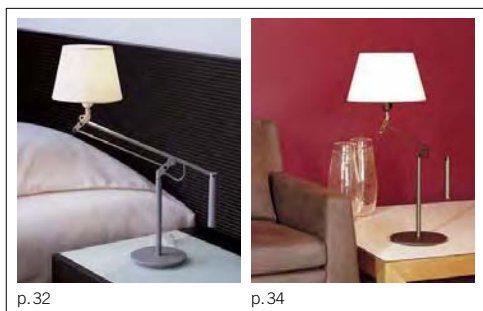

p.32

p.34

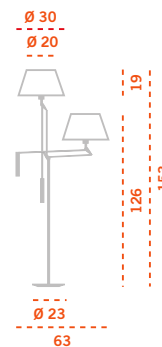



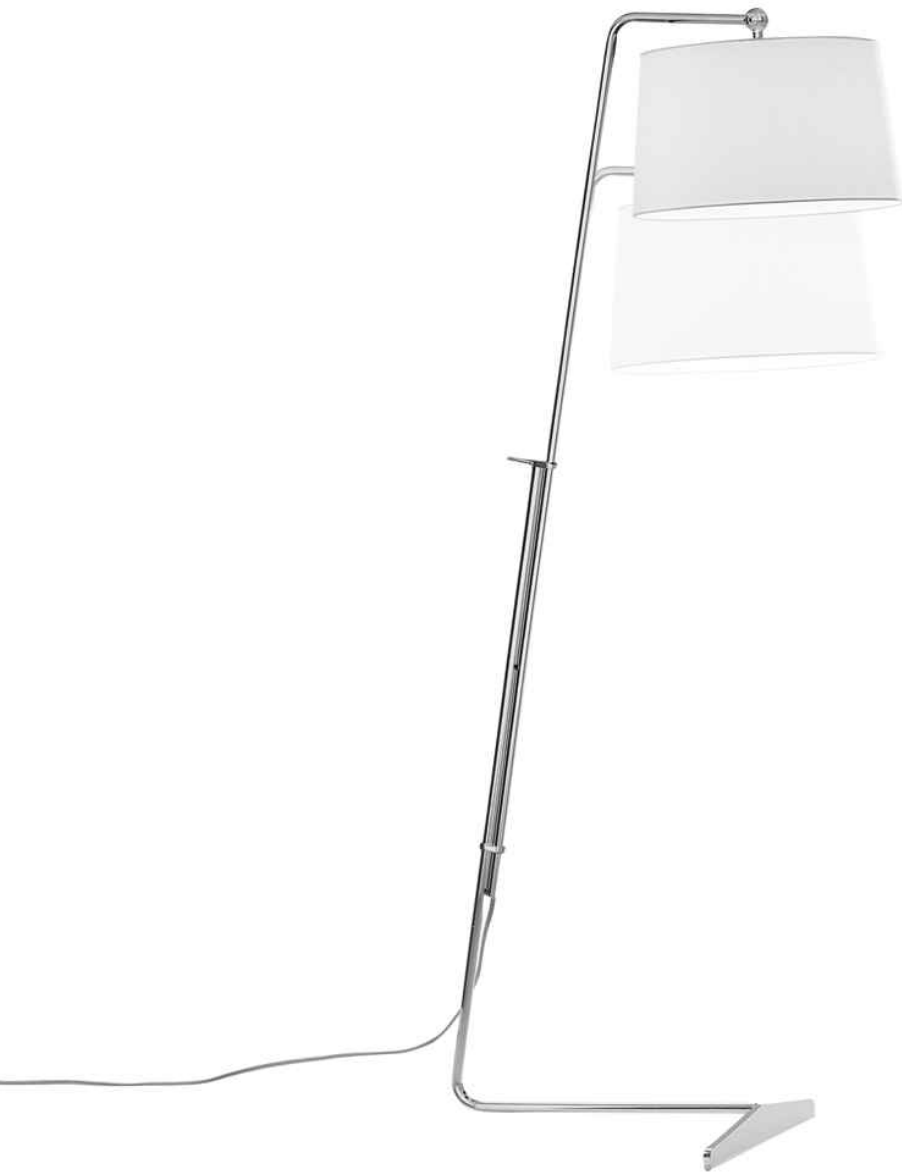

Lámpara de pie metálica con luz directa y difusa, pantalla en algodón. Se caracteriza por su brazo extensible y giratorio.

BOMBILLAS
1x100 W máx. (E-27)

ACABADOS
Cromo.

PANTALLAS
Blanca, beige y negra.

Metallic floor lamp with cotton fabric shade. Adjustable and movable arm.

BULBS
1x100 W max. (E-27)

FINISHES
Chrome.

LAMPSHADES
White, beige and black.

Stehleuchte aus Metall mit Baumwoll-Schirm mit dreh- und schwenkbarem Arm.

LAMPE
1x100 W max. (E-27)

OBERFLÄCHE
Chrom.

LAMPENSCHIRM
Weiß, beige oder schwarz.

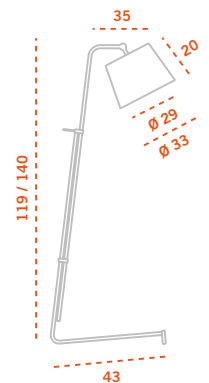



MISS SHANGAI

NAHTRANG DISSENY



Pie suelo metálico con pantalla en algodón.

BOMBILLAS
6x60 W máx. Vela (E-14)

ACABADOS
Níquel negro satinado.

PANTALLAS
Blanca, beige.

Metallic floor lamp with cotton shade.

BULBS
6x60 W max. Candle (E-14)

FINISHES
Black satin nickel.

LAMPSHADES
White and beige.

Stehleuchte aus Metall mit Baumwoll-Schirm.

LAMPE
6x 60 W max. Kerzenlampe (E-14)

OBERFLÄCHE
Nickel schwarz satiniert.

LAMPENSCHIRM
Weiß oder beige.

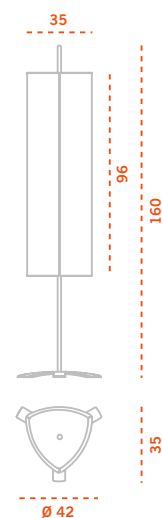



NAOMI

PORCUATRO



Lámpara pie suelo metálica.
Equipada con dimmer.

BOMBILLAS
1x150 W máx. (E-27)

ACABADOS
Estructura negra.
Cable rojo o negro.

PANTALLA
Cintas: beige, roja y negra.

Metallic floor lamp. Equipped with
dimmer.

BULBS
1x150 W max. (E-27)

FINISHES
Black structure.
Cable in red or black.

LAMPSHADES
Bookbinding tape lampshade:
beige, red and black.

Stehleuchte aus Metall mit
integriertem Dimmer.

LAMPE
1x150 W max. (E-27)

OBERFLÄCHE
Schwarz strukturiert.
Kabel wahlweise rot oder schwarz.

LAMPENSCHIRM
Buchbindung-Stil: beige, rot oder
schwarz.



p.44

p.46

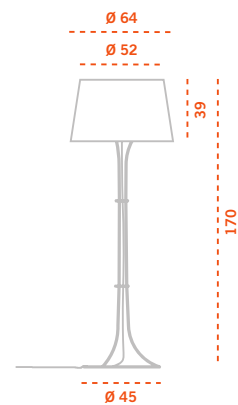



NIRVANA

GABRIEL TEIXIDÓ

Pie suelo metálico con pantalla en algodón, interruptor en el mismo portalámparas.

BOMBILLAS
1x150 W máx. (E-27)

ACABADOS
Níquel mate, marfil y negro.

PANTALLAS
- Exterior: blanca, beige y negra.
Interior: blanco.
- Exterior: negra.
Interior: naranja.

Metallic floor lamp with cotton lampshade. Switch on the lampholder.

BULBS
1x150 W max. (E-27)

FINISHES
Matt nickel, ivory and black.

LAMPSHADES
- Outside: white, beige and black.
Inside: white.
- Outside: black.
Inside: orange.

Stehleuchte aus Metall mit Lampenschirm aus Baumwolle und Schnurschalter.

LAMPE
1x150 W max. (E-27)

OBERFLÄCHE
Nickel matt, elfenbein oder schwarz.

LAMPENSCHIRM
- Außen: weiss, beige oder schwarz.
Innen: weiss.
- Außen: schwarz.
Innen: orange.

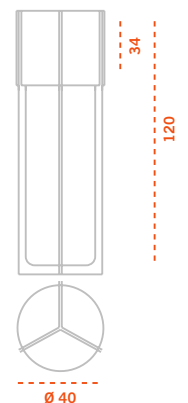



SIGNORA

GABRIEL TEIXIDÓ

Pie suelo metálico cromado con pantalla en algodón y interruptor en el mismo portalámparas. Se fabrica en tres medidas. A la medida grande se le puede incorporar dos tipos de mesas metálicas.

BOMBILLAS
2x150 W máx. (E-27)

ACABADOS
Estructura: cromo.
Mesa: metálico blanco o plomo metalizado.
Pantallas: blanca, beige y negra.

Metallic floor lamp with cotton fabric shade. Switch on the lampholder. Available in three sizes. Large size can have two types of metallic tables.

BULBS
2x150 W max. (E-27)

FINISHES
Structure: chrome.
Table: metallic white or metallic lead.
Shades: white, beige and black.

Stehleuchte aus Metall mit Baumwoll-Schirm und Zugschalter an der Lampenfassung. In drei Größen erhältlich. Als Zubehör sind zwei verschiedene Metall-Tischplatten lieferbar.

LAMPE
2x150 W max. (E-27)

OBERFLÄCHE
Leuchte: chrom
Tisch: Metall weiß oder grau-metallic
Schirme: weiß, beige oder schwarz.



ACCESORIOS
ACCESSORIES
ZUBEHÖR



Ø 41



Ø 60

Mesas / tables / tische

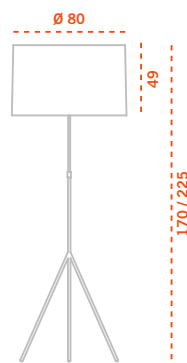

XXL

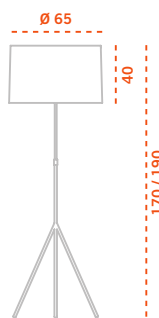

XL

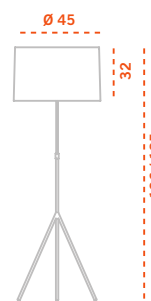

L







Pie suelo metálico halógeno.
Lámpara orientable en todos los sentidos.

BOMBILLAS
1x12V 50W máx. (M-32) Halógena.

ACABADOS
Titanio, plomo metalizado, cromo y negro.

Metallic halogen floor lamp.
Adjustable in all directions.

BULBS
1x12V 50W max. (M-32) Halogen.

FINISHES
Titanium, metallic lead, chrome, and black.

Stehleuchte aus Metall. Dreh- und schwenkbare in alle Richtungen.

LAMPE
1x12V 50W max. (M-32) Halogen.

OBERFLÄCHE
Titan, grau-metallic, chrom oder schwarz.



p.58

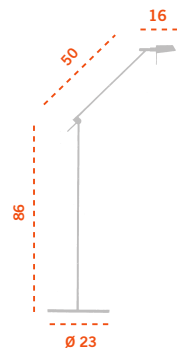





Lámpara de pie en fibra de carbono, regulable en altura con apoyo o fijación a techo. Interruptor en el mismo portalámparas.

BOMBILLAS
2 x100 W máx. (E-27)

ACABADOS
Fibra carbono negra.

PANTALLAS
Rojo y beige.

Floor lamp with flexible carbon fibre structure, height adjustable and can be attached to the ceiling. Switch on the lampholder.

BULBS
2 x100 W max. (E-27)

FINISHES
Black carbon fiber.

SHADES
Red and beige.

Leuchte mit flexiblem, längenverstellbarem Karbonstab. Die Leuchte kann zwischen Boden und Decke gespannt werden. Schalter im Lampenschirm.

LAMPE
2x100 W max. (E-27)

OBERFLÄCHE
Karbon schwarz.

LAMPENSCHIRM
Rot oder beige.

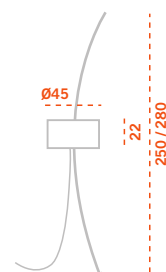



Pie de suelo con dimmer. Se caracteriza por su gran dimensión.

BOMBILLAS
1x300 W (R7S 118 mm).

ACABADOS
Cuerpo en cromo y reflector en blanco.

Metallic halogen floor lamp.
Equipped with dimmer.

BULBS
1x300 W (R7S 118 mm).

FINISHES
Chrome with white reflector.

Sehr große, um 10 cm höhenverstellbare Stehleuchte. Mit Schnurdimmer ausgestattet.

LAMPE
1x300 W max. (R7S 118 mm)

OBERFLÄCHE
Chrom mit weißem Reflektor.



ACCESORIOS
ACCESSORIES
ZUBEHÖR



Ø 41



Ø 60

mesas / tables / tische

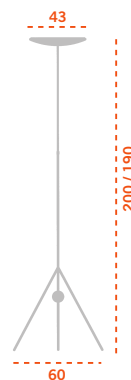



AITANA AURA FINGER FLEXIA
FRIDA FUNI IRMAMA MAX
METROPOLNICK PETRA
ROBINSON SCOTT TOMMY

COLGANTES
SUSPENSION LAMPS
PENDELLEUCHTEN

AITANA

GABRIEL TEIXIDÓ

Colgante metálico con pantalla de tela en algodón. Se fabrica en dos medidas. Equipada con un cable eléctrico de 2 m.

BOMBILLAS

- Ø 59 cm: 2x100 W máx. (E-27)
- Ø 75 cm: 2x150 W máx. (E-27)

ACABADOS

Cromo y plomo metalizado.

PANTALLAS

Blanca, beige y negra.



Metallic suspension lamp with cotton shade available in two sizes. Equipped with 2 m of cable.

BULBS

- Ø 59 cm: 2x100 W max. (E-27)
- Ø 75 cm: 2x150 W max. (E-27)

FINISHES

Chrome and metallic lead.

LAMPSHADES

White, beige and black.

Pendelleuchte aus Metall mit Baumwoll-Schirm. In zwei Größen erhältlich. Kabellänge 2 Meter.

LAMPE

- Ø 59 cm: 2x100 W max. (E-27)
- Ø 75 cm: 2x150 W max. (E-27)

OBERFLÄCHE

Chrom oder grau-metallic.

LAMPENSCHIRM

Weiß, beige oder schwarz.

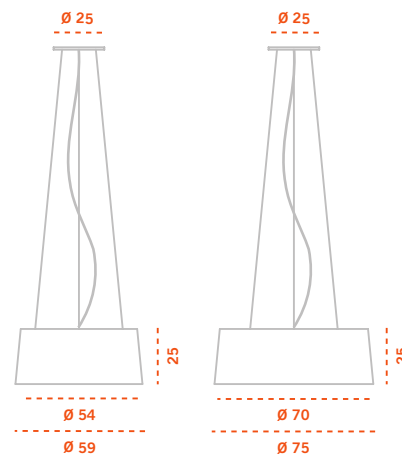
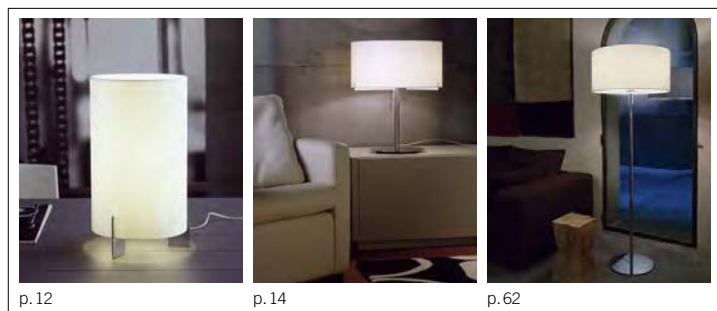

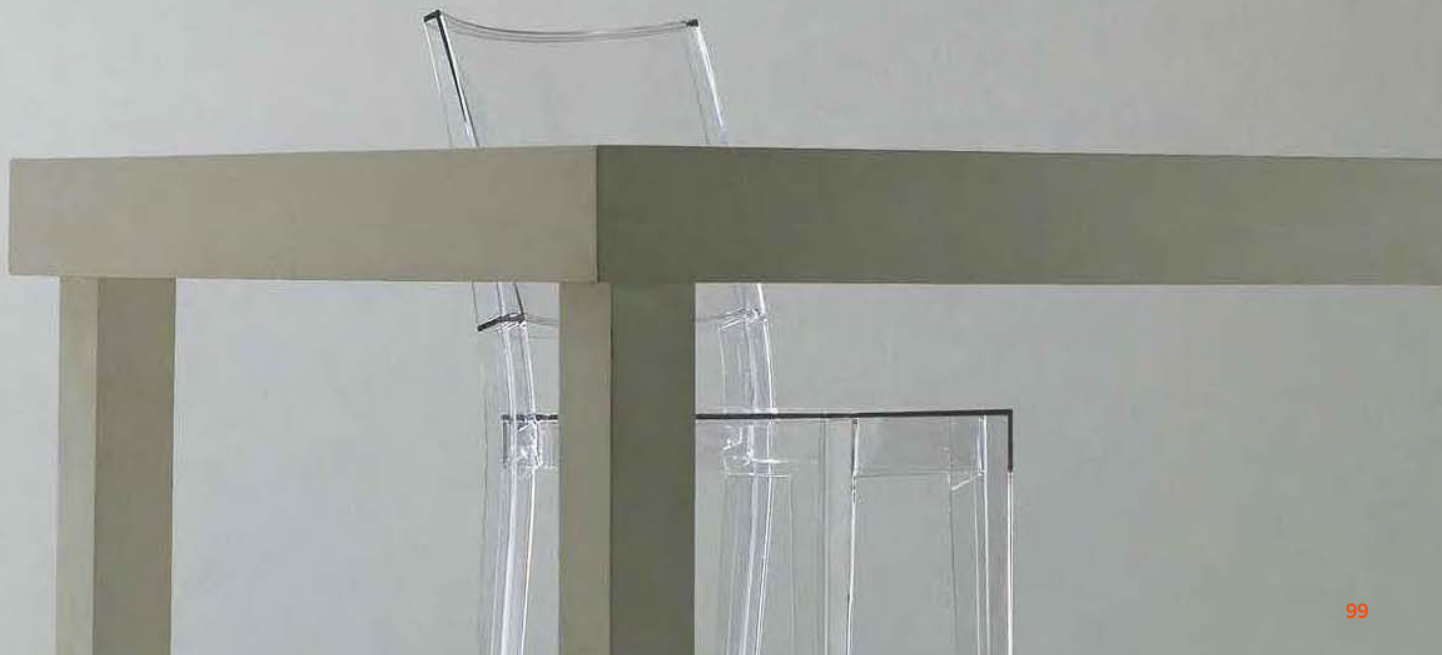

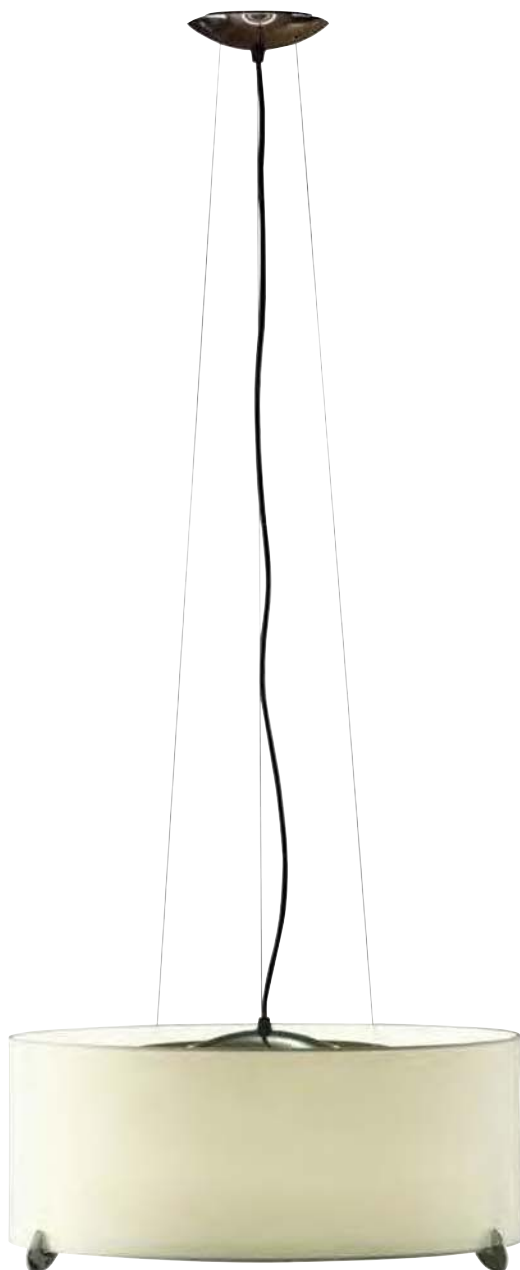

Colgante metálico con pantalla de tela en algodón. Equipada con un cable eléctrico de 2 m.

BOMBILLAS
1x150 W máx. (E-27)

ACABADOS
Cromo y plomo metalizado.

PANTALLAS
- Lisa: blanca, beige y negra.
- Plisada: beige.

Suspension lamp with cotton fabric shade. Equipped with 2 m of cable.

BULBS
1x150 W max. (E-27)

FINISHES
Chrome and metallic lead.

LAMPSHADES
- Flat: white, beige and black.
- Pleated: beige.

Pendeleuchte mit Schirm aus Baumwolltwill. Kabellänge 2 Meter.

LAMPE
1x150 W max. (E-27)

OBERFLÄCHE
Chrom oder grau-metallic.

LAMPENSCHIRM
- Glatt: grau, beige oder schwarz.
- Plissiert: beige.



p.18

p.20

p.68

p.134

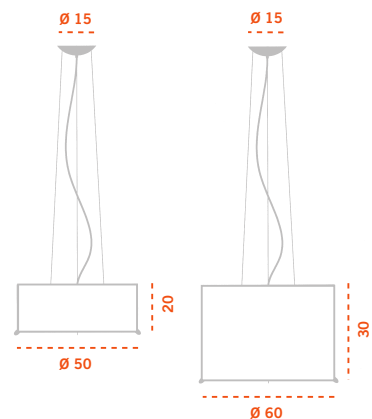



FINGER

PASCUAL SALVADOR



Colgante metálico con o sin brazo móvil. El brazo facilita la movilidad de la lámpara en un radio de 75 cm y tiene un ángulo de giro de 360°. Equipados con un cable eléctrico de 1,7 m.

BOMBILLAS
2x100 W máx. (E-27)

ACABADOS
Plomo metalizado y oro metalizado.
Pantalla: blanca o beige.

Suspension lamp with or without moving arm. The moving arm allows the lamp to move in a radius of 75 cm and has an angle of turn of 360°. Equipped with 1,7 m of cable.

BULBS
2x100 W max. (E-27)

FINISHES
Metallic lead or metallic gold.
Shades: white or beige.

Pendelleuchte mit oder ohne beweglichem Arm. Der bewegliche Arm erlaubt es, die Leuchte um 360° zu drehen und in einem Radius von 75 cm zu bewegen. Kabellänge 1,7 Meter.

LAMPE
2x100 W max. (E27)

OBERFLÄCHE
Grau-metallic lead oder gold-metallic.
Schirm: weiß oder beige.

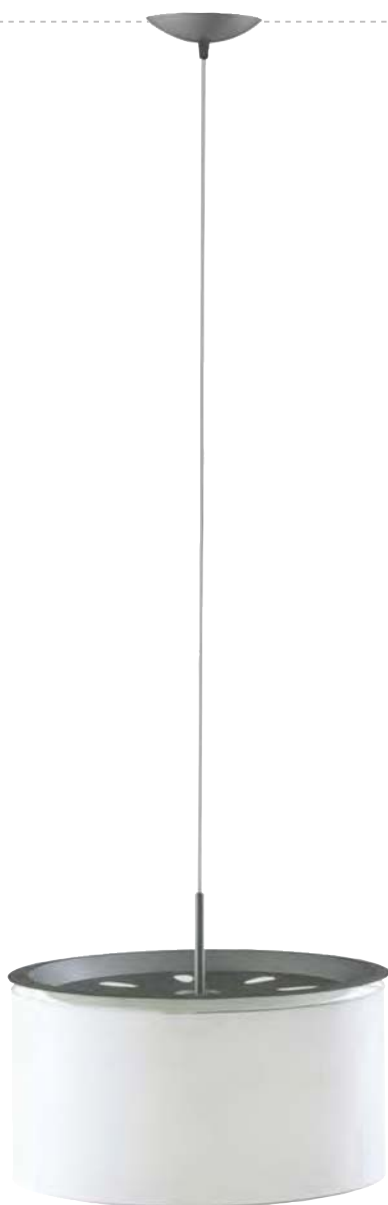

Fijo / Fixed / Starr

Móvil / Rotating / Drehbar

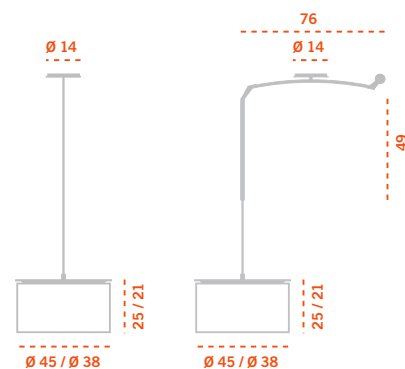



FLEXIA

DAIFUKU DESIGNS + FREDERIC CALLIS

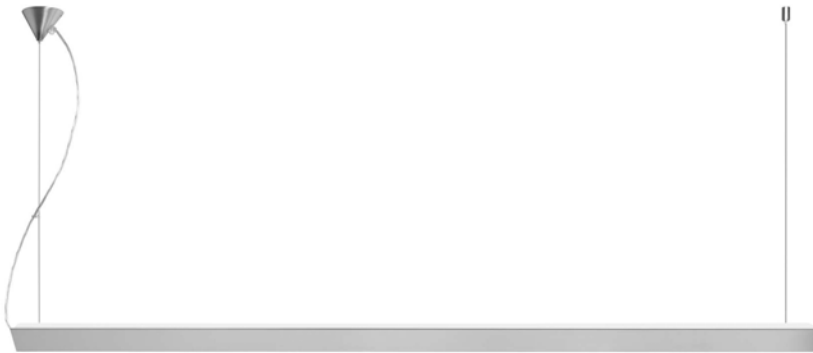

Sistema de iluminación de emisión directa o indirecta, para lámpara fluorescente lineal TL5 con reactancia electrónica incorporada. Instalación a techo.

BOMBILLAS

- 65 cm: 2x24 W máx. TL5
- 95 cm: 2x39 W máx. TL5
- 125 cm: 2x54 W máx. TL5
- 155 cm: 2x80 W máx. TL5

ACABADOS

Acero inoxidable satinado.
Difusor: acrílico mate rayado.

Complete system of direct and indirect lighting for linear fluorescent tube TL5 with incorporated electronic ballast. Installation to ceiling.

BULBS

- 65 cm: 2x24 W max. TL5
- 95 cm: 2x39 W max. TL5
- 125 cm: 2x54 W max. TL5
- 155 cm: 2x80 W max. TL5

FINISHES

Satin stainless steel.
Diffuser: matt engraved acrylic.

System zur direkten und indirekten Beleuchtung für Leuchtstofflampe TL5 und integriertem elektronischen Vorschaltgerät. Für Deckenmontage.

LAMPE

- 65 cm: 2x24 W max. TL5
- 95 cm: 2x39 W max. TL5
- 125 cm: 2x54 W max. TL5
- 155 cm: 2x80 W max. TL5

OBERFLÄCHE

Gehäuse aus satiniertem Edelstahl,
Diffusor aus matt geprägtem Acryl.



p. 150

p. 152

Colgante / Suspension lamp / Pendelleuchten

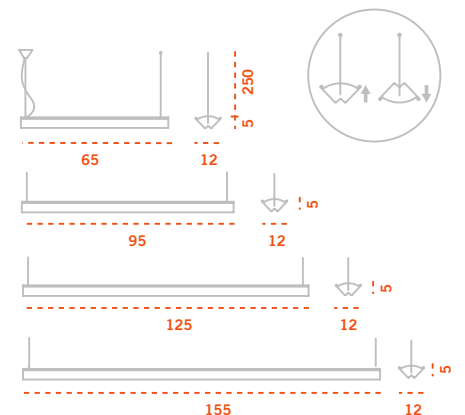



FLEXIA

DAIFUKU DESIGNS + FREDERIC CALLIS





FRIDA

GABRIEL TEIXIDÓ



Colgantes en cristal óptico, estructura metálica. Se fabrica en dos diámetros. Equipadas con un cable eléctrico de 1,7 m.

BOMBILLAS

- Ø 57 cm:
1x150 W máx. (B-15d) Halógena.
- Ø 76 cm:
1x250 W máx. (E-27) Halógena.

ACABADOS

Cromo.

Suspension light with optical glass, metallic body. Available in two sizes. Equipped with 1,7 m of cable.

BULBS

- Ø 57 cm:
1x150 W max. (B-15d) Halogen.
- Ø 76 cm:
1x250 W max. (E-27) Halogen.

FINISHES

Chrome.

Pendelleuchte mit satiniertem Glas, Gehäuse aus Chrom. In zwei Größen erhältlich. Kabellänge 1,7 Meter.

LAMPE

- Ø 57 cm:
1x150 W max. (B-15d) Halogen.
- Ø 76 cm:
1x250 W max. (E-27) Halogen.

OBERFLÄCHE

Chrom.

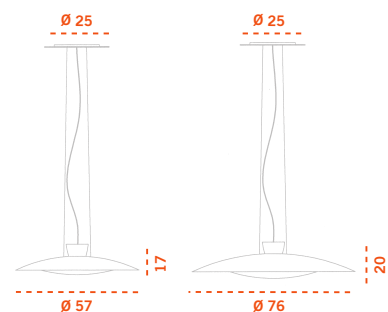



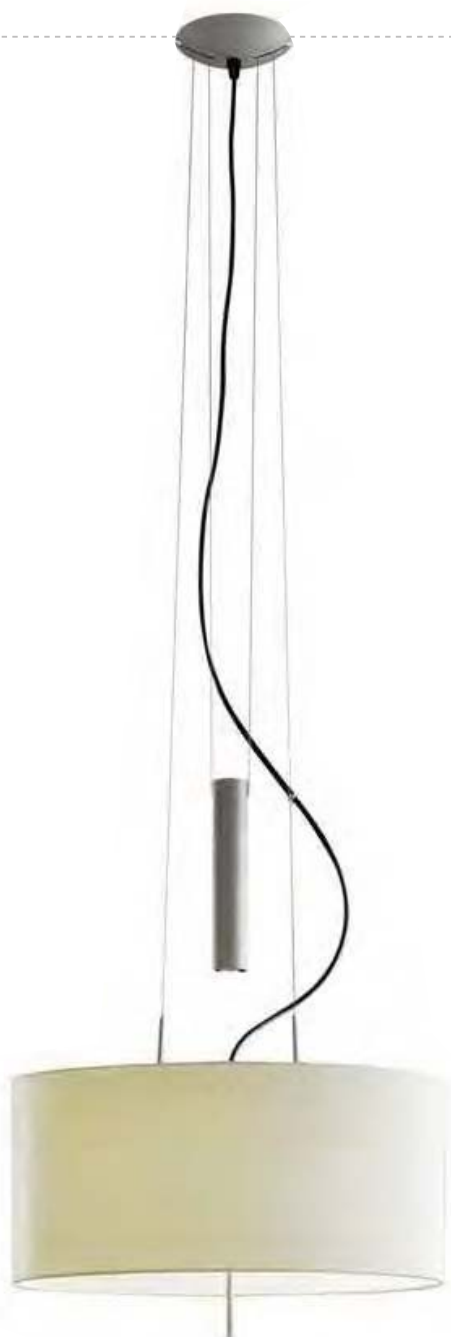

Colgante metálico que sube y baja, con pantalla ovalada de tela en algodón. Equipada con un cable eléctrico de 2 m.

BOMBILLAS
2x100 W máx. (E-27)

ACABADOS
Plomo metalizado y oro metalizado.
Pantallas: blanca, beige.

Metallic suspension lamp with oval cotton shade which goes up and down. Equipped with 2 m of cable.

BULBS
2x100 W max. (E-27)

FINISHES
Metallic lead and metallic gold.
Shades: white or beige.

Pendelleuchte aus Metall mit ovalem Baumwoll-Schirm, höhenverstellbar. Kabellänge 2 Meter.

LAMPE
2x100 W max. (E-27)

OBERFLÄCHE
Grau-metallic oder gold-metallic.
Schirm: weiß oder beige.

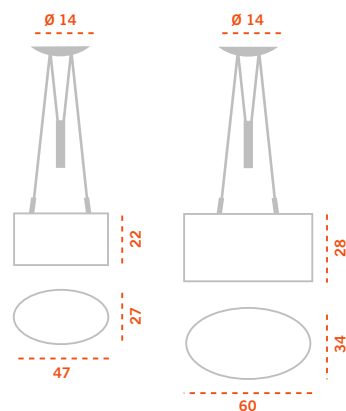





Colgantes con pantalla metálica, disponible en dos medidas.

Equipada con un cable eléctrico de 1,7 m.

BOMBILLAS

- 25 cm: 1x60 W máx.
(E-27 Globe 60 mm)
- 40 cm: 1x100 W máx.
(E-27 Globe 80 mm)

ACABADOS

- Exterior: gris metalizado, blanco y negro.
- Interior: blanco o teja.

Suspension lamp with metallic lampshade available in two sizes. Equipped with 1,7 m of cable.

BULBS (incandescent)

- 25 cm: 1x60 W max.
(E-27 Globe 60 mm)
- 40 cm: 1x100 W max.
(E-27 Globe 80 mm)

FINISHES

- Outside: metallic grey, white and black.
- Inside: white or brick.

Pendelleuchte mit Metallschirm in 2 verschiedenen Durchmessern. Kabellänge 1,7 Meter.

LAMPE

- 25 cm: 1x60 W max.
(Globelampe 60 mm E27)
- 40 cm: 1x100 W max.
(Globelampe 80 mm E27)

OBERFLÄCHE

- Metallschirm außen: grau metallic, weiß oder schwarz.
- Metallschirm innen: weiß oder rotbraun.

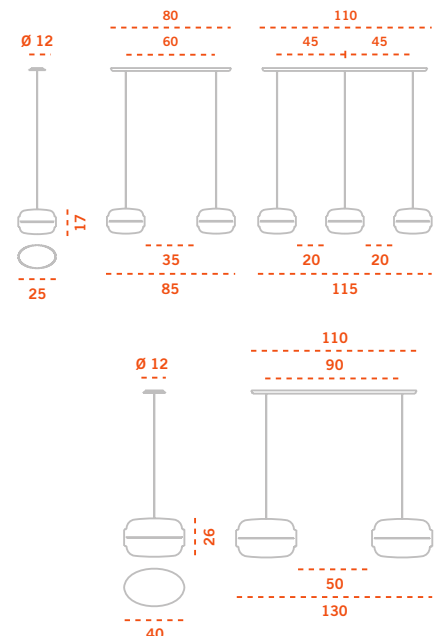





Colgante metálico de pared, brazo telescópico. Interruptor en el mismo portalámparas. Va equipada con un cable eléctrico de 5 m.

BOMBILLAS

1x150 W máx. (E-27)

ACABADOS

Metal: cromo.

Pantallas: blanca, beige y negro.

Metallic suspension wall lamp, telescoped arm. Incorporated switch. Equipped with 5 m of cable.

BULBS

1x150 W max. (E-27)

FINISHES

Metal: chrome.

Shades: white, beige and black.

Pendelleuchte mit Teleskoparm und eingebautem Schalter. Kabellänge 5 Meter.

LAMPE

1x150 W max. (E-27)

OBERFLÄCHE

Metall: Chrom.

Schirme: weiß, beige oder schwarz.



METROPOL



VENTAJAS DEL VENTILADOR

- Refresca en los meses de calor.
- Facilita una rápida eliminación de olores desagradables y humo.
- En invierno permite una utilización más racional de la calefacción: seleccionando la velocidad mínima, el aparato envía hacia abajo el aire caliente concentrado en el techo manteniendo una temperatura constante.

ADVANTAGES OF A FAN UNIT

- To cool the room during summer months.
- To facilitate rapid elimination of unpleasant smells and smoke.
- To allow in winter a more rational use of the heating system: if left to turn at a minimum speed, it will actually bring the hot air that concentrates towards the ceiling back down into the room, thus maintaining a more even constant temperature at floor level.

VORTEILE EINES VENTILATORS

- Kühlt den Raum während der Sommermonate.
- Vertreibt Rauch und unangenehme Gerüche.
- Unterstützt im Winter eine optimale Ausnutzung der Heizung. Bei kleiner Umdrehung wird die warme Luft von der Decke wieder in den Raum zurück transportiert und bewirkt so eine konstantere Raumtemperatur.

Ventilador con luz. Equipado con mando a distancia.

Importante: altura mínima de la aspa al suelo 230 cm.

BOMBILLAS

1x150 W máx. (R7S 80 mm)

POTENCIA MOTOR

75 W - 230 V

ACABADOS

Estructura y aspas: metal pintado en plomo metalizado.

Tapa motor en perspex, colores: transparente, rojo, naranja, azul y amarillo.

Ceiling fan with light. Equipped with remote control.

Attention: minimum height distance between the blade and the floor 230 cm.

BULBS

1x150 W max. (R7S 80 mm)

POWER MOTOR

75 W - 230 V

FINISHES

Structure and blades: metal painted in metallic lead.

Motor cover in perspex, colors: transparent, red, orange, blue and yellow.

Deckenventilator mit integrierter Leuchte inkl. Fernbedienung.

Achtung: Minimaler Abstand zwischen Boden und Unterkante Ventilator = 230 cm.

LAMPE

1x150 W max. (R7S 80 mm)

MOTORLEISTUNG

75 W - 230 V

OBERFLÄCHE

Gehäuse und Rotorblätter: Metall, grau-metallic lackiert.

Motorgehäuse aus Kunststoff, Farben: transparent, rot, orange, blau oder gelb.

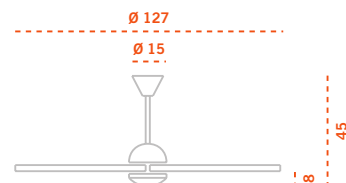



NICK

Colgante: cristal prensado mate.
Equipada con un cable eléctrico
de 1,7 m.

BOMBILLAS
1x100 W máx. (E-27)

ACABADOS
Plomo metalizado.

Suspension of striped frosted glass.
Equipped with 1,7 m of cable.

BULBS
1x100 W max. (E-27)

FINISHES
Metallic lead.

Pendelleuchte mit mattiertem,
relliertem Glasschirm. Kabellänge
1,7 Meter.

LAMPE
1x100 W max. (E-27)

OBERFLÄCHE
Grau-metallic.

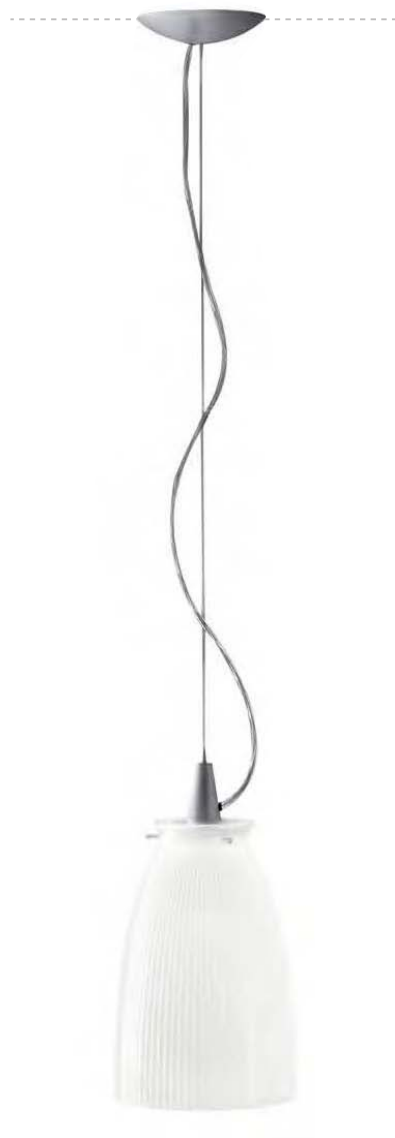



PETRA

JORDI MILÀ + JORDI TEIXIDÓ



Colgante metálico con cristal blanco. Equipada con un cable eléctrico de 1,7 m.

BOMBILLAS
1x75 W máx. (E-27)

ACABADOS
Plomo metalizado.

Metallic suspension lamp with white glass. Equipped with 1,7 m of cable.

BULBS
1x75 W max. (E-27)

FINISHES
Metallic grey.

Pendelleuchte aus Metall mit weißem Glas. Kabellänge 1,7 Meter.

LAMPE
1x75 W max. (E-27)

OBERFLÄCHE
Grau-metallic.



ROBINSON

GABRIEL TEIXIDÓ

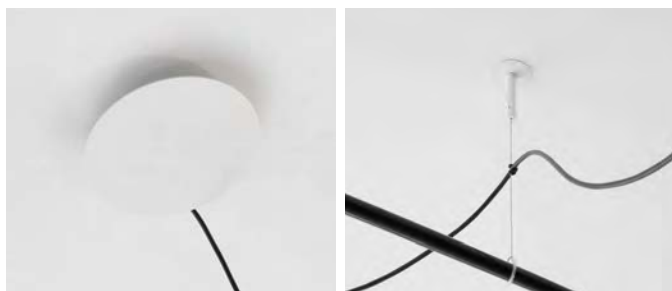

Colgante móvil, gira en sentido circular (360°) y basculante. Pantalla en algodón con interruptor en el mismo portalámparas. Caña de fibra, color negro. Se fabrica en dos medidas.

Equipadas con cable eléctrico de 2,5 m (pequeña) o 3,5 m (grande).

BOMBILLAS

1x150 W máx. (E-27)

ACABADOS

Fibra negra.

PANTALLAS

Blanca, beige y negra.

Mobile suspension lamp with a turn of 360° and tilting. Cotton fabric shade with switch on the lampholder. Black fibre structure, black colour. Available in two sizes. Equipped with 2,5 m (small) or 3,5 m (large) of cable.

BULBS

1x150 W max. (E-27)

FINISHES

Black fibre.

SHADES

White, beige and black.

Pendelleuchte 360° drehbar und kippbar. Baumwoll-Schirm, Schalter in Fassung integriert. Leuchtenstab aus Fiberglas. Erhältlich in zwei Größen. Kabellänge 2,5 Meter (klein) oder 3,5 Meter (groß).

LAMPE

1x150 W max. (E-27)

OBERFLÄCHE

Fiberglas schwarz.

LAMPENSCHIRM

Weiß, beige und schwarz.

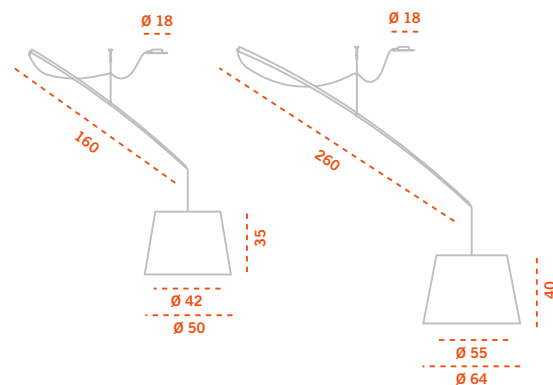





Colgantes metálicos con cristal opal blanco. Se fabrican en dos medidas. Equipadas con un cable eléctrico de 1,7 m.

BOMBILLAS

- Mini:
1x60 W máx. (E-14)
- Grande:
1x100 W máx. (E-27)

ACABADOS

Cromo.

Metallic suspension lamps with white opal glass. Available in two sizes. Equipped with 1,7 m of cable.

BULBS

- Mini:
1x60 W max. (E-14)
- Big:
1x100 W max. (E-27)

FINISHES

Chrome.

Pendelleuchte aus Metall mit weißem Opalglas. In zwei Größen erhältlich. Kabellänge 1,7 Meter.

LAMPE

- Klein:
1x60 W max. (E-14)
- Groß:
1x100 W max. (E-27)

OBERFLÄCHE

Chrom.



p.208

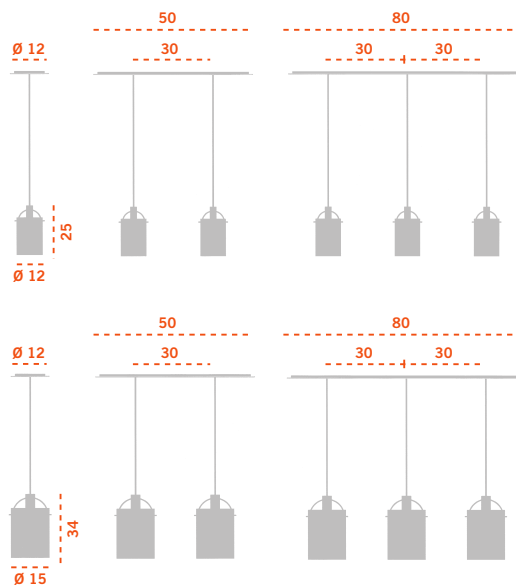



TOMMY

JORDI MILÀ (EDDA DESIGN)



Colgante metálico con cristal opal blanco. Equipado con un cable eléctrico de 1,7 m.

BOMBILLAS
1x75 W máx. (E-27)

ACABADOS
Plomo metalizado y titanio.

Metallic suspension lamp with white opal glass. Equipped with 1,7 m of cable.

BULBS
1x75 W max. (E-27)

FINISHES
Metallic lead and titanium.

Pendelleuchte aus Metall mit weißem Schirm aus Opalglas. Kabellänge 1,7 Meter.

LAMPE
1x75 W max. (E-27)

OBERFLÄCHE
Grau-metallic oder titan.

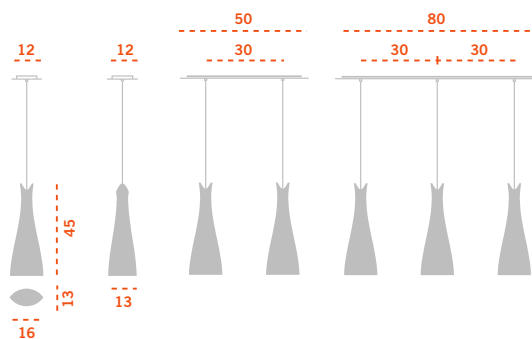



ALFAÁREAAURABARCINO
BASICBERTABOXSTERCITY
DIALFLASHFLEXIAFOCUS
FOCUSMINIFRITZGALA
GALLERYGAMMAGILDA
HAMILTONHANSHI-FI
HOTELHOTEL-PYTHON
INFINITIJACKYKEOPSKIWI
MERCURYMINIMONDRIAN
MORGANMORGAN45°
ODYSSEYORLYPASCUALINA
PYTHONRISRITASCOTT
SQUARESNAIKSUITE
SUNSETTOPUDON
VALENTINAVIPERVIPS
WAKIZENIT

APLIQUES, PLAFONES, PINZAS, FOCOS
CEILING, WALL AND CLIP-ON LAMPS, SPOTLIGHTS
DECKENLEUCHTEN, WANDLEUCHTEN, KLEMMLEUCHTEN, STRAHLER

ALFA, GAMMA

GABRIEL TEIXIDÓ

Apliques metálicos con pantalla cristal opal blanco.

BOMBILLAS

- Alfa: 1x150 W máx. (E-27)

- Gamma: 1x26 W máx. (G24D3)

ACABADOS

Cromo y plomo metalizado.

Metallic wall sconces with white opal glass.

BULBS

- Alfa: 1x150 W max. (E-27)

- Gamma: 1x26 W max. (G24D3)

FINISHES

Chrome and metallic lead.

Wandleuchte mit Gehäuse aus Metall und opalweißem Glas.

LAMPE

- Alfa: 1x150 W max. (E-27)

- Gamma: 1x26 W max. (G24D3)

OBERFLÄCHE

Chrom oder grau-metallic.



ALFA



GAMMA

ALFA

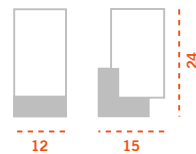

GAMMA

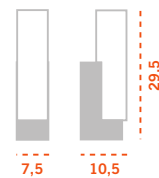



Aplique provisto de doble cristal con la posibilidad de insertar fotos, logos, etc. Se fabrica en dos versiones: con interruptor o sin.

BOMBILLAS
1x100 W máx. (E-27)
1x18 W máx. (G24-D2)

ACABADOS
Anodizado gris natural.

Wall lamp with double glass which gives the possibility to insert photos, logos, etc. Available with or without switch.

BULBS
1x100 W max. (E-27)
1x18 W max. (G24-D2)

FINISHES
Anodized natural grey.

Wandleuchte mit Doppelglas, mit der Möglichkeit Fotos einzufügen. Mit oder ohne Zugschalter lieferbar.

LAMPE
1x100 W max. (E-27)
1x18 W max. (G-24 D2)

OBERFLÄCHE
Grau-eloxiert.

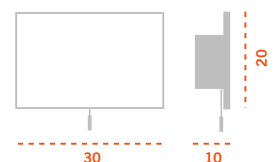
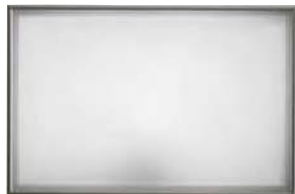



Aplique metálico con pantalla de tela en algodón. Interruptor en el mismo portalámparas.

BOMBILLAS
1x100 W máx. (E-27)

ACABADOS
Cromo y plomo metalizado.

PANTALLAS
- Lisa: blanca, beige y negra.
- Plisada: beige.

Wall lamp with cotton fabric shade.
Switch on the same lampholder.

BULBS
1x100 W máx. (E-27)

FINISHES
Chrome and metallic lead.

LAMPSHADES
- Flat: white, beige and black.
- Pleated: beige.

Wandleuchte mit Baumwollschirm.
Schalter in der Fassung integriert.

LAMPE
1x100 W max. (E-27)

OBERFLÄCHE
Chrom oder grau-metallic.

LAMPENSCHIRM
- Glatt: grau, beige oder schwarz.
- Plissiert: beige.



p.18

p.20

p.68

p.100

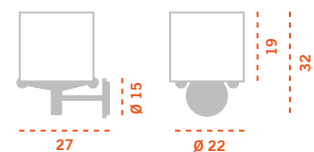



Aplique metálico halógeno.
BOMBILLAS
1x300 W máx. (R7S 118 mm)
ACABADOS
Cromo y plomo metalizado.

Metallic wall lamp.
BULBS
1x300 W max. (R7S 118 mm)
FINISHES
Chrome and metallic lead.

Wandleuchte aus Metall.
LAMPE
1x300 W max. (R7S 118 mm)
OBERFLÄCHE
Chrom oder grau-metallic.







Plafón o aplique metálico con cristal opal blanco. Tres medidas.

BOMBILLAS

- 20 cm:
1x100 W máx. (R7S 80 mm)
- 30 cm:
1x200 W máx. (R7S 118 mm)
2x18 W máx. (G-24 D2)
- 46 cm:
1x300 W máx. (R7S 118 mm)
3x18 W máx. (G-24 D2)

ACABADOS

Blanco y plomo metalizado.

Metallic wall light or ceiling lamp with white opal diffuser. Available in three sizes.

BULBS

- 20 cm:
1x100 W max. (R7S 80 mm)
- 30 cm:
1x200 W max. (R7S 118 mm)
2x18 W max. (G-24 D2)
- 46 cm:
1x300 W max. (R7S 118 mm)
3x18 W max. (G-24 D2)

FINISHES

White and metallic lead.



Decken- oder Wandleuchte aus Metall mit opal-weißem Glas. In drei Größen erhältlich.

LAMPE

- 20 cm:
1x100 W max. (R7S 80 mm)
- 30 cm:
1x200 W max. (R7S 118 mm)
2x18 W (G-24 D2)
- 46 cm:
1x300 W max. (R7S 118 mm)
3x18 W (G-24 D2)

OBERFLÄCHE

Weiß oder grau- metallic.

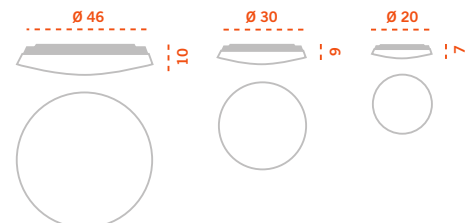

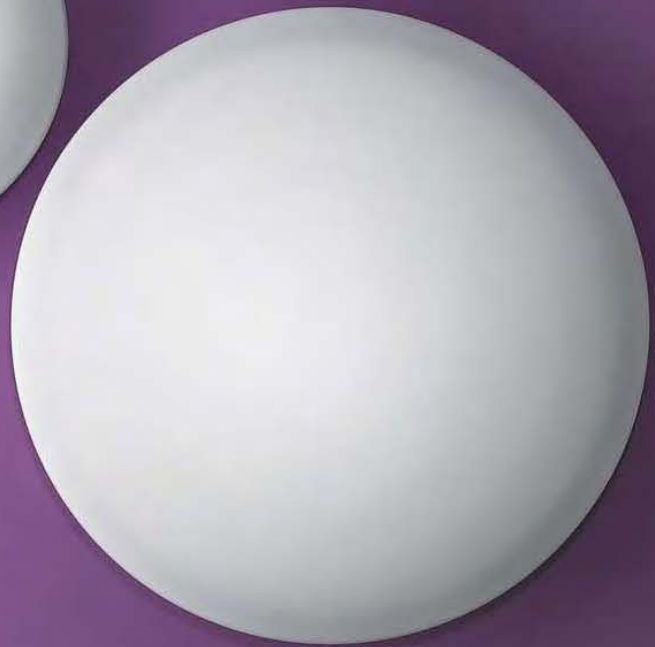

BERTA, SUITE

GABRIEL TEIXIDÓ

Aplique cristal curvado gravado mate.

BOMBILLAS

- Berta:
1x100 W máx. (E-27)
2x7-9 W máx. (G-23)
- Suite:
1x150 W máx. (R7S 80 mm)

ACABADOS

Oro brillante, cromo y plomo metalizado.

Wall lamp glass opaque engraved curved.

BULBS

- Berta:
1x100 W max. (E-27)
2x7-9 W max. (G-23)
- Suite:
1x150 W max. (R7S 80 mm)

FINISHES

Bright gold, chrome and metallic lead.

Wandleuchte mit gebogenem, mattiertem Glasschirm.

LAMPE

- Berta:
1x100 W max. (E-27)
2x7-9 W max. (G-23)
- Suite:
1x150 W max. (R7S 80 mm)

OBERFLÄCHE

Gold hochglanz, chrom oder grau-metallic.

BERTA



SUITE



BERTA

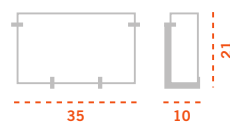
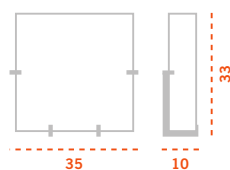

SUITE

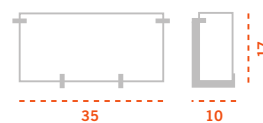



BOXSTER

PASCUAL SALVADOR



Plafón o aplique metálico cristal curvado blanco. Se fabrican en tres medidas.

BOMBILLAS

- Mini:

1x100 W máx. (R7S 80 mm)
o bajo consumo 2x13 W máx.
(G24-Q1)

- Mediano:

1x200 W máx. (R7S 118 mm)
o bajo consumo 2x26 W máx.
(G24-Q3)

- Grande:

1x300 W máx. (R7S 118 mm)
o bajo consumo 3x26 W máx.
(G24-Q3)

ACABADOS

Cromo y plomo metalizado.

Metallic wall or ceiling lamp. White curved glass. Available in 3 sizes.

BULBS

- Mini:

1x100 W max. (R7S 80 mm) or
low energy 2x13 W max. (G24-Q1)

- Medium:

1x200 W max. (R7S 118 mm)
or low energy 2x26 W max.
(G24-Q3)

- Large:

1x300 W max. (R7S 118 mm)
or low energy 3x26 W max.
(G24-Q3)

FINISHES

Chrome and metallic lead.

Decken- oder Wandleuchte aus weißem Glas. In drei Größen lieferbar.

LAMPE

- Mini:

1x100 W max. (R7S 80 mm)
oder 2x13 W (G24-Q1)

- Medium:

1x200 W max. (R7S 118 mm)
oder 2x26 W (G24-Q3)

- Groß:

1x300 W max. (R7S 118 mm)
oder 3x26 W (G24-Q3)

OBERFLÄCHE

Chrom oder grau-metallic.

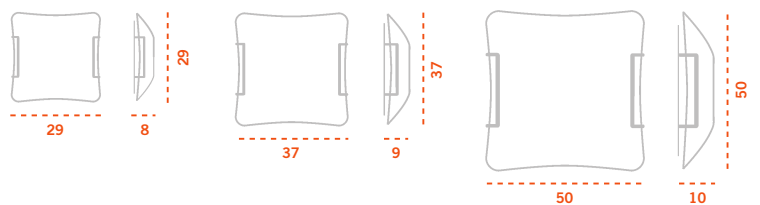



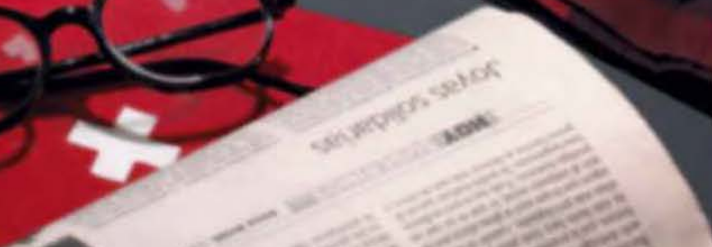

Aplicue metálico orientable en todos los sentidos. Reflector giratorio 360°, incorpora interruptor.

BOMBILLAS
1x75 W máx. (G9) Halógena.

ACABADOS
Cromo.

Metallic wall lamp rotating in all directions. The reflector rotates 360° and incorporates an on-off switch.

BULBS
1x75 W max. (G9) Halogen.

FINISHES
Chrome.

Wandleuchte aus Metall. Dreh- und schwenkbar, Reflektor um 360° drehbar mit integriertem Schalter.

LAMPE
1x75 W max. (G9) Halogen.

OBERFLÄCHE
Chrom.

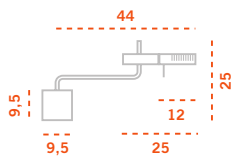
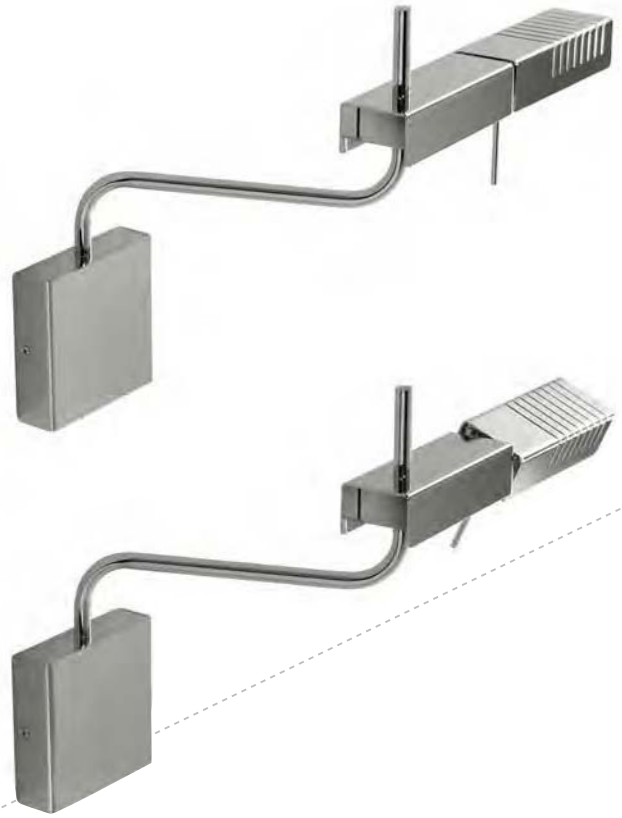

Plafón o aplique de acero inoxidable con transformador incorporado.
Se puede adaptar dos, tres o cuatro focos. Se fabrica en versión individual, de superficie o para empotrar en techo.

BOMBILLAS
QR111 12v 100 W máx.

ACABADOS
Acero inoxidable satinado.



Wall or ceiling lamp with transformer in stainless steel for two, three or four lights. Also available as individual light or to embed in the ceiling.

BULBS
QR111 12v 100 W max.

FINISHES
Satin stainless steel.

Wand- oder Deckenleuchte aus Edelstahl mit integriertem elektronischem Transformator für zwei, drei oder vier Strahler. Auch als Einzelleuchte für Wandmontage, Deckeneinbau- oder Deckenanbau lieferbar.

LAMPE
QR111 12v 100 W max.

OBERFLÄCHE
Edelstahl satiniert.

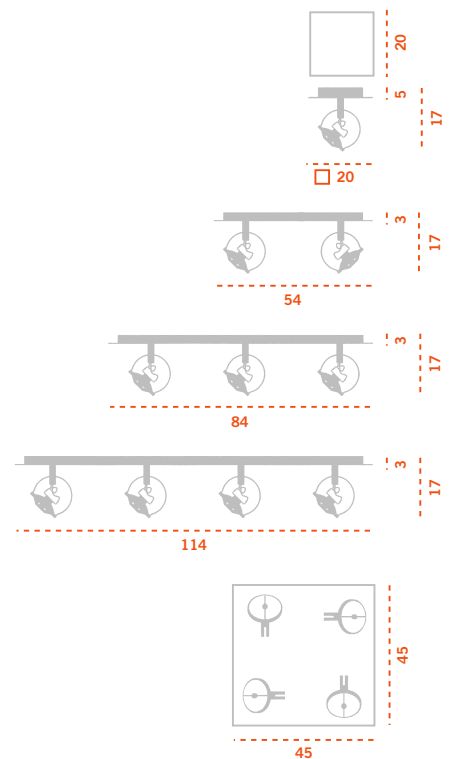



Perfil de aluminio en el cual se pueden adaptar dos, tres o cuatro focos.

BOMBILLAS
Hi-Spot ES-63 75 W (GZ-10)

ACABADOS
Plomo metalizado.

Aluminium track for two, three or four spotlights.

BULBS
Hi-Spot ES-63 75 W (GZ-10)

FINISHES
Metallic lead.

Aluminium-Profil mit zwei, drei oder vier Strahlern.

LAMPE
Hi-Spot ES-63 75 W (GZ-10)

OBERFLÄCHE
Grau-metallic.

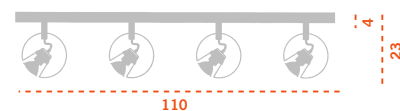
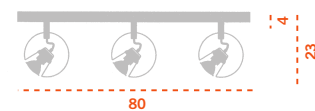
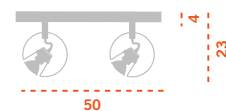



FLEXIA

DAIFUKU DESIGNS + FREDERIC CALLIS



Sistema de iluminación de emisión directa o indirecta, para lámpara fluorescente lineal TL5 con reactancia electrónica incorporada. Instalación a pared.

BOMBILLAS

- 65 cm: 2x24 W máx. TL5
- 95 cm: 2x39 W máx. TL5
- 125 cm: 2x54 W máx. TL5
- 155 cm: 2x80 W máx. TL5

ACABADOS

Acero inoxidable satinado.
Difusor: acrílico mate rayado.

Complete system of direct and indirect lighting for linear fluorescent tube TL5 with incorporated electronic ballast. Installation to wall.

BULBS

- 65 cm: 2x24 W max. TL5
- 95 cm: 2x39 W max. TL5
- 125 cm: 2x54 W max. TL5
- 155 cm: 2x80 W max. TL5

FINISHES

Satin stainless steel.
Diffuser: matt engraved acrylic.

System zur direkten und indirekten Beleuchtung für Leuchtstofflampe TL5 und integriertem elektronischen Vorschaltgerät. Für Wandmontage.

LAMPE

- 65 cm: 2x24 W max. TL5
- 95 cm: 2x39 W max. TL5
- 125 cm: 2x54 W max. TL5
- 155 cm: 2x80 W max. TL5

OBERFLÄCHE

Gehäuse aus satiniertem Edelstahl,
Diffusor aus matt geprägtem Acryl.



Columna-aplique / Column-wall lamp /
Wand-Ausleger-Leuchte

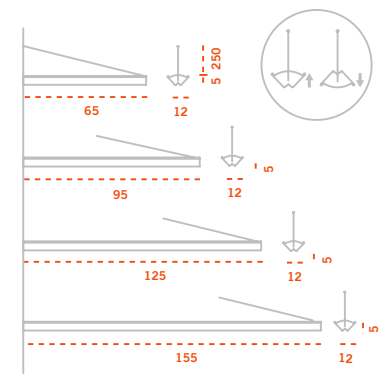



FLEXIA

DAIFUKU DESIGNS + FREDERIC CALLIS



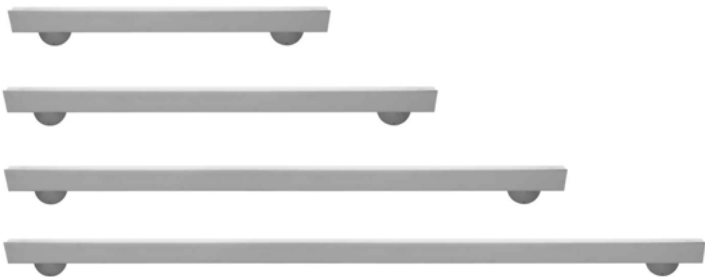

Aplique / Wall lamp / Wandleuchte

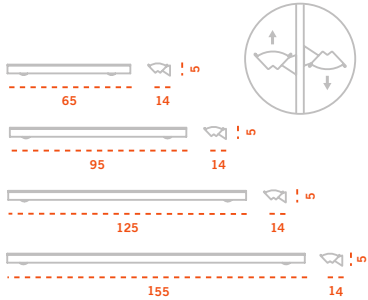

p. 104

p. 150

FOCUS, FOCUS MINI

GABRIEL TEIXIDÓ



FOCUS MINI



FOCUS



FOCUS

Perfil de aluminio en el cual se pueden adaptar dos, tres o cuatro focos. Se fabrican en versión individual.

BOMBILLAS

- Focus Mini:
Hi-Spot ES-63 75 W (GZ-10)
- Focus:
Hi-Spot 95 75 W máx. (E-27)
Concentra R80 100 W máx. (E-27)
Concentra R63 60 W máx. (E-27)

ACABADOS

Plomo metalizado.

Aluminium support which combines two, three or four spotlights. Also available as individual light.

BULBS

- Focus Mini:
Hi-Spot ES-63 75 W (GZ-10)
- Focus:
Hi-Spot 95 75 W max. (E-27)
Concentra R80 100 W max. (E-27)
Concentra R63 60 W max. (E-27)

FINISHES

Metallic lead.

Aluminium-Profil für zwei, drei oder vier Strahler. Auch als Einzelleuchte erhältlich.

LAMPE

- Focus Mini:
Hi-Spot ES-63 75 W (GZ-10)
- Focus:
Hi-Spot 95 75 W max. (E-27)
Concentra R80 100 W max. (E-27)
Concentra R63 60 W max. (E-27)

OBERFLÄCHE

Grau-metallic.





FOCUS MINI

FOCUS MINI

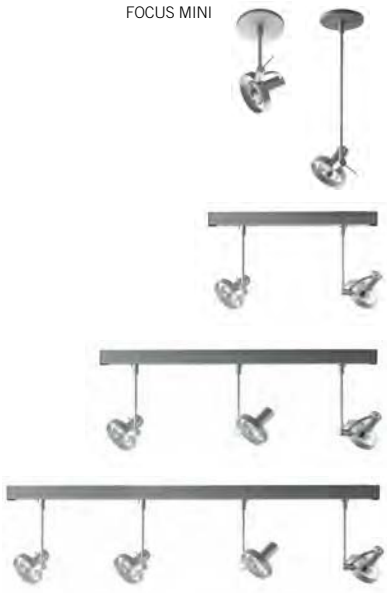

FOCUS, FOCUS MINI

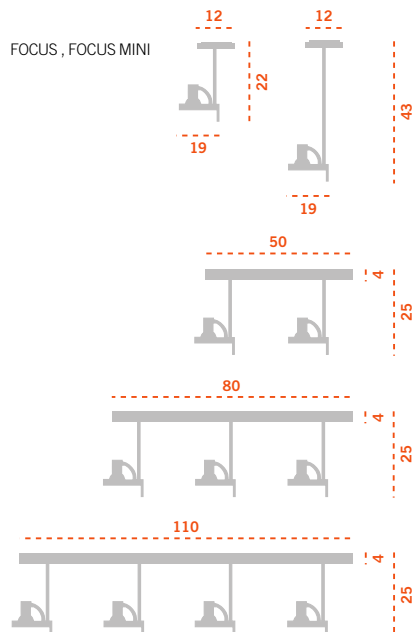

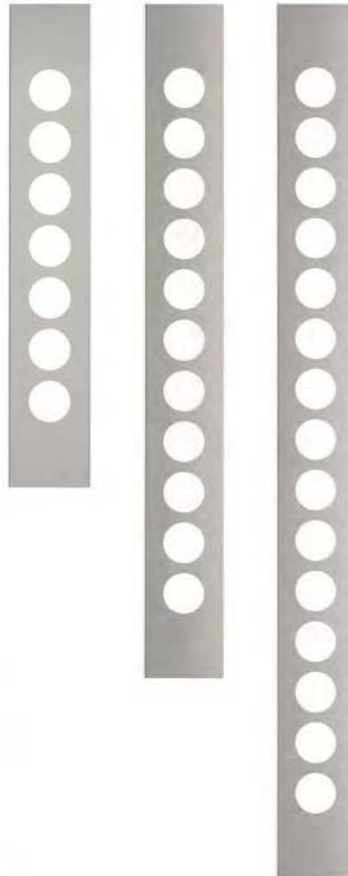

Conjunto de apliques metálicos.
Su posición de trabajo puede ser
vertical u horizontal.

BOMBILLAS

- 70 cm: 2x24 W máx. (TL5)
- 100 cm: 2x39 W máx. (TL5)
- 130 cm: 2x54 W máx. (TL5)

ACABADOS

Acero Inoxidable satinado.

Metallic wall lamp set which
can be mounted vertically or
horizontally.

BULBS (low energy)

- 70 cm: 2x24 W max. (TL5)
- 100 cm: 2x39 W max. (TL5)
- 130 cm: 2x54 W max. (TL5)

FINISHES

Satin stainless steel.

Wandleuchte. Profileuchte aus
Edelstahl. Für vertikale und
horizontale Montage geeignet.

LAMPE

- 70 cm: 2x24 W (TL5)
- 100 cm: 2x39 W (TL5)
- 130 cm: 2x54 W (TL5)

OBERFLÄCHE

Edelstahl satiniert.

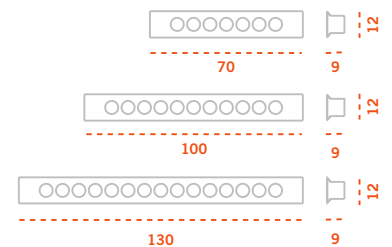

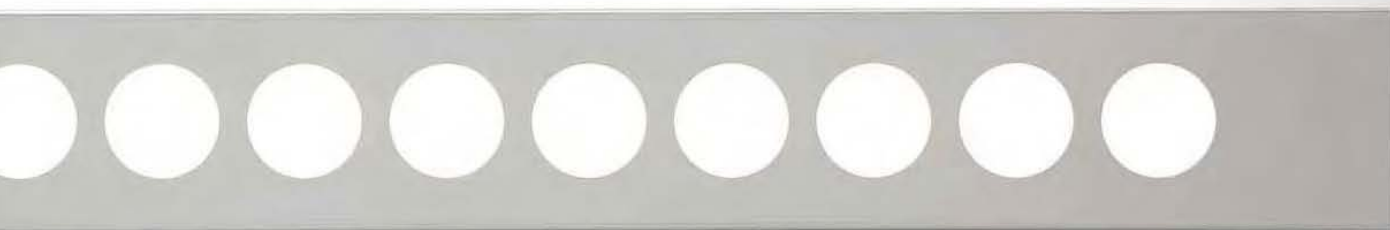



Aplique metálico.

BOMBILLAS

- Gala (pantalla triple):
1x300 W máx. (R7S 118 mm)
- Gala mini (pantalla doble):
1x60 W máx. (E-14)

ACABADOS

Plomo metalizado y oro metalizado.

Metallic wall lamp.

BULBS

- Gala (triple shade):
1x300 W max. (R7S 118 mm)
- Gala mini (double shade):
1x60 W max. (E-14)

FINISHES

Metallic lead and metallic gold.

Wandleuchte aus Metall.

LAMPE

- Gala (mit dreifachem Schirm):
1x300 W max. (R7S 118 mm)
- Gala mini (mit zweifachem Schirm):
1x60 W max. (E-14)

OBERFLÄCHE

Grau- oder gold-metallic.



GALA

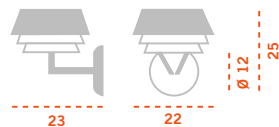

GALA MINI



GALLERY

GABRIEL TEIXIDÓ

Conjunto de apliques para cuadros en dos tipos de pantalla reflectora A (ángulo recto), B (curvado).

BOMBILLAS (halógenas)

- 15 cm: 1x20 W máx. (G-4)

- 30 cm: 2x20 W máx. (G-4)

- 40 cm: 2x20 W máx. (G-4)

ACABADOS

Cromo y plomo metalizado.

Gallery A has a squared reflector.

Gallery B a curved reflector.

BULBS (halogen)

- 15 cm: 1x20 W max. (G-4)

- 30 cm: 2x20 W max. (G-4)

- 40 cm: 2x20 W max. (G-4)

FINISHES

Chrome and metallic lead.

Wandleuchte aus Metall mit rechtwinkligem oder gebogenem Reflektor für Bilder und Gemälde.

LAMPE (halogen)

- 15 cm: 1x20 W max. (G-4)

- 30 cm: 2x20 W max. (G-4)

- 40 cm: 2x20 W max. (G-4)

OBERFLÄCHE

Chrom oder grau-metallic.

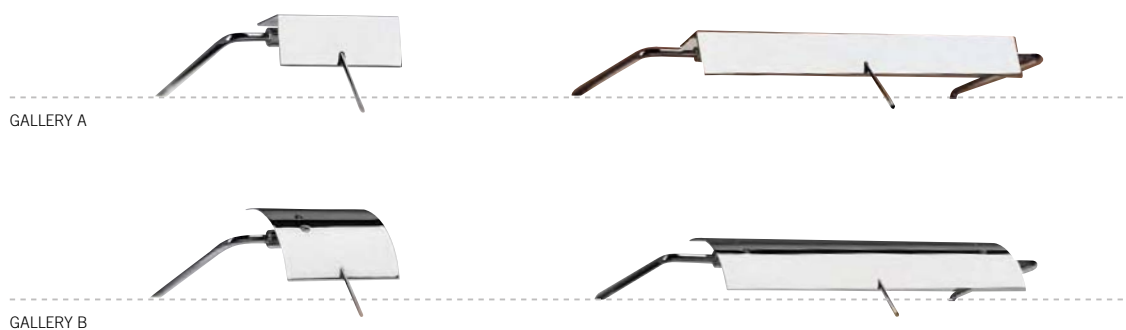

GALLERY A



GALLERY B



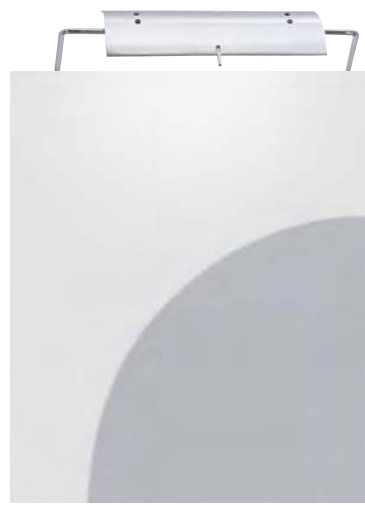
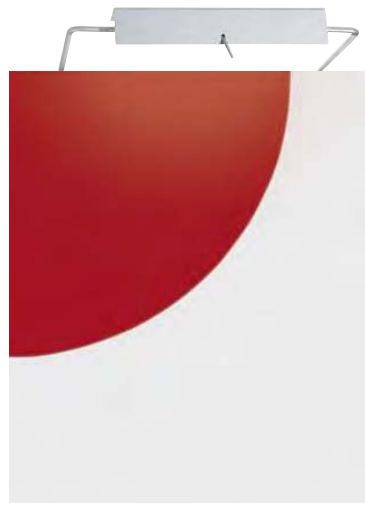



Apliques metálicos con brazo en madera. Se fabrican en dos medidas.

BOMBILLAS

- Pequeña: 1x60 W máx. (E-14).
- Grande: 1x100 W máx. (E-27).

ACABADOS

Estructura: plomo metalizado.
Madera: wenge, cerezo y haya natural.
Pantallas: blanca y beige.

Metallic wall lamps with wooden stem. Available in two sizes.

BULBS

- Small: 1x60 W max. (E-14).
- Large: 1x100 W max. (E-27).

FINISHES

Structure: metallic grey.
Wood: wenge, dark cherry and beech.
Shades: white and beige.

Wandleuchte aus Metall mit Holzapplikation. In zwei Größen erhältlich.

LAMPE

- Klein: 1x60 W max. (E-14).
- Groß: 1x100 W max. (E-27).

OBERFLÄCHE

Leuchte: grau-metallic.
Hölzer: Wenge, Kirsche oder Buche.
Schirme: weiß oder beige.

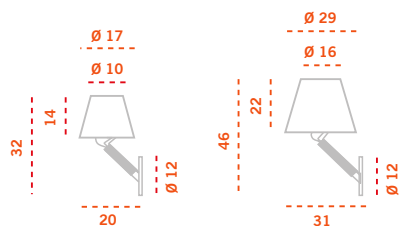

p. 36

HAMILTON

PASCUAL SALVADOR



Plafón o aplique en cristal curvado mate. Se fabrica en cuatro medidas.

BOMBILLAS

- Rectangular, 30 cm:
1x100 W (E-27)
1x26 W (G-24 D3)
- Cuadrado, 30 cm:
1x200 W (R7S 118 mm)
2x18 W (TC-L2G11)
- Cuadrado, 38 cm:
1x200 W (R7S 118 mm)
2x24 W (TC-L2G11)
- Cuadrado, 50 cm:
1x300 W (R7S 118 mm)
2x36 W (TC-L2G11)

ACABADOS

Cromo.

Wall or ceiling lamp with curved frosted glass. Available in four sizes.

BULBS

- Rectangular, 30 cm:
1x100 W (E-27)
1x26 W (G-24 D3)
- Square, 30 cm:
1x200 W (R7S 118 mm)
2x18 W (TC-L2G11)
- Square, 38 cm:
1x200 W (R7S 118 mm)
2x24 W (TC-L2G11)
- Square, 50 cm:
1x300 W (R7S 118 mm)
2x36 W (TC-L2G11)

FINISHES

Chrome.

Wand- oder Deckenleuchte aus Metall mit gebogenem, mattiertem Glas. In vier Größen erhältlich.

LAMPE

- Rechteckig, 30 cm:
1x100 W (E-27)
1x26 W (G-24 D3)
- Quadratisch, 30 cm:
1x200 W (R7S 118 mm)
2x18 W (TC-L2G11)
- Quadratisch, 38 cm:
1x200 W (R7S 118 mm)
2x24 W (TC-L2G11)
- Quadratisch, 50 cm:
1x300 W (R7S 118 mm)
2x36 W (TC-L2G11)

OBERFLÄCHE

Chrom.

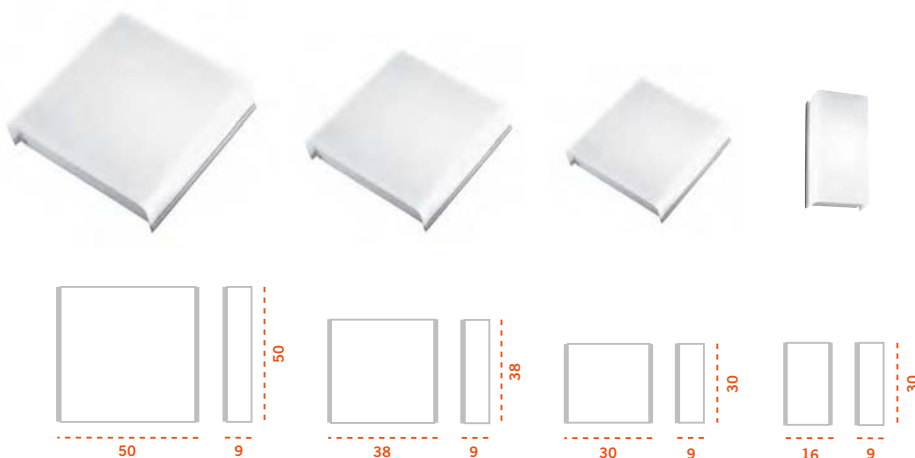





Aplique rectangular metálico, bañador de luz, disponible en dos medidas.

BOMBILLAS

- 41 cm: 2x24 W máx. (TC-L2G11 bajo consumo)
- 72 cm: 2x24 W máx. (TL5)

ACABADOS

- Exterior: gris metalizado, blanco, negro y níquel mate.
- Interior: blanco y teja.

Metallic rectangular wall lamp, wall washer, available in two sizes.

BULBS

- 41 cm: 2x24 W max. (TC-L2G11 low energy)
- 72 cm: 2x24 W max. (TL5)

FINISHES

- Outside: metallic grey, white, black and matt nickel.
- Inside: white and brick.

Wandleuchte aus Metall, rechteckig, Lichtaustritt asymmetrisch, lieferbar in 2 Größen.

LAMPE

- 41 cm: 2x24 W max. (TC-L Kompaktleuchtstofflampe)
- 72 cm: 2x24 W max. (T5 Leuchtstofflampe)

OBERFLÄCHE

- Außen: grau metallic, weiß, schwarz oder nickel matt.
- Innen: weiß oder rotbraun.

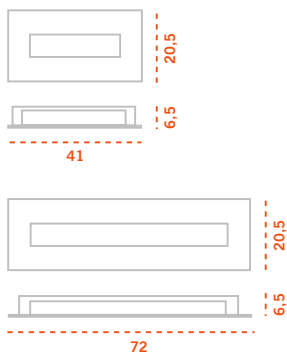

p. 168

HANS CUADRADO
NAHTRANG DISSENY



Aplique cuadrado metálico
bañador de luz.

BOMBILLAS
2 x24 W máx. (TC-L2G11)
Bajo consumo.

ACABADOS
- Exterior: gris metalizado, blanco,
negro y níquel mate.
- Interior: blanco y teja.

Metallic square wall lamp, wall
washer.

BULBS
2 x24 W max. (TC-L2G11)
Low energy.

FINISHES
- Outside: metallic grey, white, black
and matt nickel.
- Inside: white and brick.

Wandleuchte aus Metall,
quadratisch, Lichtaustritt
asymmetrisch.

LAMPE
2 x24 W max. (TC-L2G11)
Kompaktleuchtstofflampe.

OBERFLÄCHE
- Außen: grau metallic, weiß,
schwarz oder nickel matt.
- Innen: weiß oder rotbraun

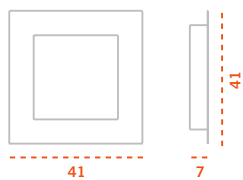
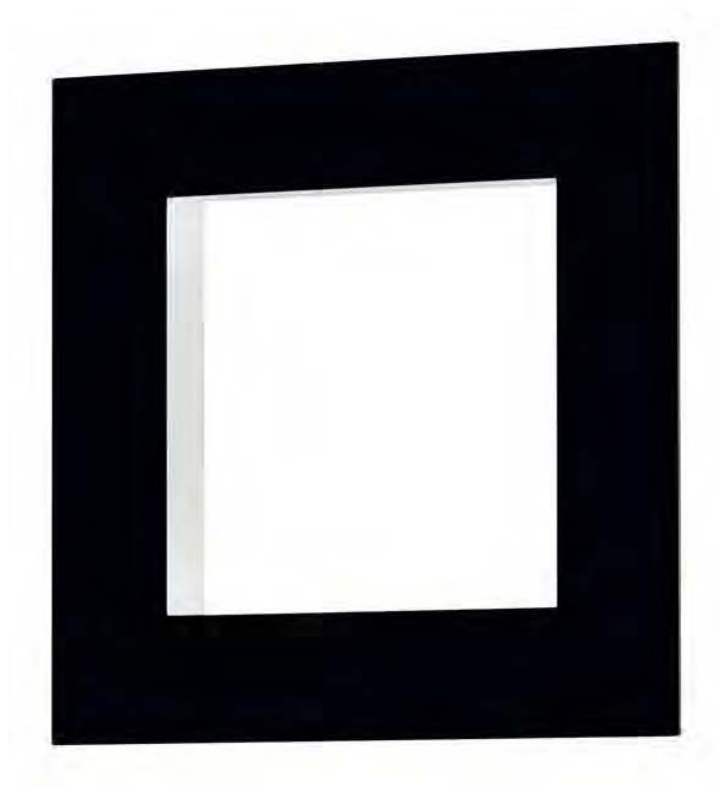

Lámpara pinza con interruptor incorporado. Luz halógena. Pantalla orientable 360°. Se caracteriza por su comodidad de manejo al estar equipada con un cable de 3 m. Pinza adaptable hasta 35 mm de grueso.

BOMBILLAS
2x20 W máx. (G-4)

ACABADOS
Acero inoxidable.

Clip-on lamp (35 mm opening) with incorporated switch. Halogen light. Shade orientated at 360°. Very easy to handle, equipped with 3 m of cable.

BULBS
2x20 W max. (G-4)

FINISHES
Stainless steel.



Klemmleuchte mit integriertem Schalter. Lampenschirm vertikal schwenkbar. Einfache Montage. Inklusive 3 Meter Kabel. Klemme lässt sich bis 35 mm Materialstärke montieren.

LAMPE
2x20 W max. (G-4)

OBERFLÄCHE
Edelstahl.



DELTA DE PLATA 1997
ADI-FAD

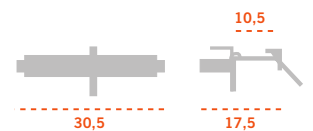



HOTEL



Aplique metálico con pantalla en algodón, interruptor en la base.
Se fabrica con pantalla cuadrada o redonda.

BOMBILLAS
1x60 W máx. (E-14)

ACABADOS
Níquel mate.
Pantallas: blanca, beige y negra.

Metallic wall lamp with cotton
lampshade, switch on the base.
Made with square or round shade.

BULBS
1x60 W max. (E-14)

FINISHES
Matt nickel.
Lampshades: white, beige and black.

Wandleuchte aus Metall mit
quadratischem oder rundem
Lampenschirm aus Baumwolle
und integriertem Schalter.

LAMPE
1x60 W max. (E-14)

OBERFLÄCHE
Nickel matt.
Lampenschirm: weiß, beige oder
schwarz.

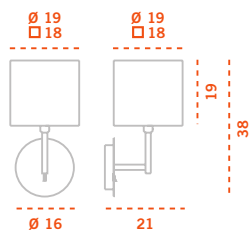

p. 174

HOTEL-PYTHON

DAIFUKU DESIGNS

Aplique metálico con pantalla en algodón, interruptores en la base. Se fabrica con pantalla cuadrada o redonda. Incorpora un flexo con LED.

BOMBILLAS

- 1x60 W máx. (E14)
- Flexo: 1x1,4 W LED máx. 45 lumen. Color blanco (6000 K). Ángulo de apertura 60°.

ACABADOS

Níquel mate.

Pantallas en algodón:

- Redondas o cuadradas.
- Blanco, beige o negro.

Metallic wall lamp with a cotton shade, and control switches on its base. The lamp is available with square or round shades, and includes a flexible shaft with a LED.

BULBS

- 1x60 W max. (E14)
- Flexible shaft: 1x1,4 W max. 45 lumen. White color (6000 K). 60° lighting angle.

FINISHES

Matt nickel.

Cotton lampshade:

- Square or round.
- White, beige or black.

Wandleuchte aus Metall mit quadratischem oder rundem Lampenschirm aus Baumwolle und integriertem Doppelschalter für Wandleuchte bzw. für LED Leselicht im Flexschlauch.

LAMPE

- 1x60 W max. (E14)
- Flexschlauch: 1x1,4 W LED mit max. 45 lumen. Lichtfarbe neutralweiß (6000 K). Ausstrahlungswinkel 60°.

OBERFLÄCHE

Gehäuse nickel matt.

Lampenschirm:

- Rund oder eckig.
- Baumwollstoff weiß, beige oder schwarz.



p.172

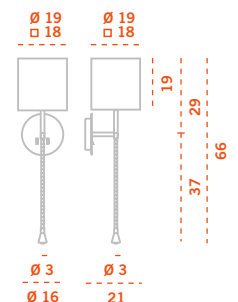





Conjunto de apliques metálicos en aluminio inyectado, su posición de trabajo puede ser vertical u horizontal.

BOMBILLAS

- 50 cm: 1x24 W máx. (TC-L2G11)
- 75 cm: 2x24 W máx. (TL5)
- 100 cm: 2x39 W máx. (TL5)
- 130 cm: 2x54 W máx. (TL5)

ACABADOS

Plomo metalizado.

Metallic wall set, injected aluminium. Can be mounted vertically or horizontally.

BULBS

- 50 cm: 1x24 W max. (TC-L2G11)
- 75 cm: 2x24 W max. (TL5)
- 100 cm: 2x39 W max. (TL5)
- 130 cm: 2x54 W max. (TL5)

FINISHES

Metallic lead.

Wandleuchte aus Aluminium. In vier Größen erhältlich. Vertikale und horizontale Montage möglich.

LAMPE

- 50 cm: 1x24 W max. (TC-L2G11)
- 75 cm: 2x24 W max. (TL5)
- 100 cm: 2x39 W max. (TL5)
- 130 cm: 2x54 W max. (TL5)

OBERFLÄCHE

Grau-metallic.

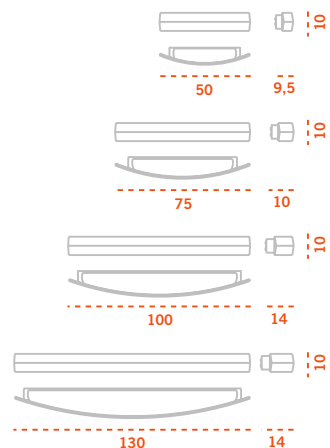



JACKY

Plafón o aplique metálico con cristal opal blanco. 4 medidas.

BOMBILLAS

- 16 cm: 1x25 W máx. (G9)
Halógena
- 21 cm: 1x60 W máx. (E-14)
Halógena
- 26 cm: 1x60 W máx. (E-14)
Incandescente
- 31 cm: 2x60 W máx. (E-14)
Incandescente

ACABADOS

Blanco.

Metallic ceiling or wall lamp with white opal glass. Available in 4 sizes.

BULBS

- 16 cm: 1x25 W max. (G9)
Halogen
- 21 cm: 1x60 W max. (E-14)
Incandescent
- 26 cm: 1x60 W max. (E-14)
Incandescent
- 31 cm: 2x60 W max. (E-14)
Incandescent

FINISHES

White.

Decken- oder Wandleuchte aus Metall und weißem Opalglas in 4 verschiedenen Durchmessern.

LAMPE

- 16 cm: 1x25 W max. (G9)
Halogen
- 21 cm: 1x60 W max. (E14)
Halogen
- 26 cm: 1x60 W max. (E14)
Incandescent
- 31 cm: 2x60 W max. (E14)
Incandescent

OBERFLÄCHE

Gehäuse: weiß.
Glas: opalweiß.

IP 44

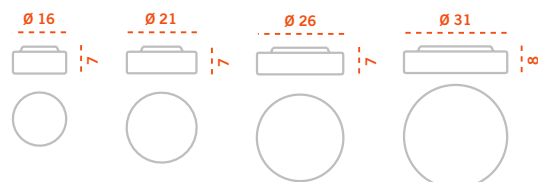



Aplique o plafón metálico con cristal opal blanco.

BOMBILLAS
1x26 W máx. (G24-Q3 bajo consumo).

ACABADOS
Blanco.

Metallic wall or ceiling lamp with white opal glass.

BULBS
1x26 W max. (G24-Q3 low energy)

FINISHES
White.

Wand- oder Deckenleuchte aus Metall mit opalweißem Glas.

LAMPE
1x26 W max. (G24-Q3)

OBERFLÄCHE
Weiß.

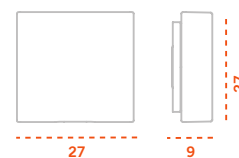



Plafón o aplique metálico con cristal opal blanco, de pequeñas dimensiones.

BOMBILLAS
1x60 W máx. (E-14)

ACABADOS
Cromo.

Metallic ceiling or wall lamp with white opal glass of small dimensions.

BULBS
1x60 W max. (E-14)

FINISHES
Chrome.

Wand- oder Deckenleuchte aus Metall mit opalweißem Glas.

LAMPE
1x60 W max. (E-14)

OBERFLÄCHE
Chrom.





MERCURY

GABRIEL TEIXIDÓ

Apliques en cristal óptico curvado blanco.

BOMBILLAS

- Mercury 1:

1x100 W máx. (E-27) o

2x18 W máx. (G24-Q2)

- Mercury 2:

2x100 W máx. (E-27) o

2x24 W máx. (TC-L 2G11)

ACABADOS

Cromo y plomo metalizado.

Wall lamp with white curved optical glass.

BULBS

- Mercury 1:

1x100 W max. (E-27) or

2x18 W max. (G24-Q2)

- Mercury 2:

2x100 W max. (E-27) or

2x24 W max. (TC-L 2G11)

FINISHES

Chrome and metallic lead.

Wandleuchte mit gebogenem, weißem Glas.

LAMPE

- Mercury 1:

1x100 W max. (E-27) oder

2x18 W max. (G24-Q2)

- Mercury 2:

2x100 W max. (E-27) oder

2x24 W max. (TC-L 2G11)

OBERFLÄCHE

Chrom oder grau-metallic.



MERCURY 1



MERCURY 2

MERCURY 1

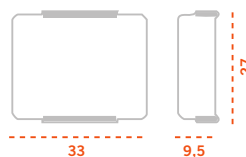

MERCURY 2

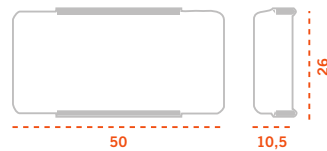



MINI

Aplique o plafón metálico con cristal, de pequenas dimensións.

BOMBILLAS
1x40 W máx. (G9)

ACABADOS
Cromo.

Metallic wall or ceiling lamp with glass of small dimensions.

BULBS
1x40 W max. (G9)

FINISHES
Chrome.

Wand- oder Deckenleuchte mit Glas.

LAMPE
1x40 W max. (G9)

OBERFLÄCHE
Chrom.

IP 44

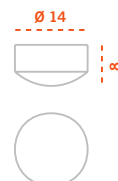



MONDRIAN

DAAIFUKU DESIGNS



Aplique para iluminar cuadros,
reflector movible 340°.

BOMBILLAS

- 37 cm: 1x6 W máx.
(Ø 7 mm FM T2) Osram
- 47 cm: 1x8 W máx.
(Ø 7 mm FM T2) Osram
- 68 cm: 1x13 W máx.
(Ø 7 mm FM T2) Osram

ACABADOS

Níquel mate.



Family of picture-lamps, reflector
adjustable over 340°.

BULBS

- 37 cm: 1x6 W max.
(Ø 7 mm FM T2) Osram
- 47 cm: 1x8 W max.
(Ø 7 mm FM T2) Osram
- 68 cm: 1x13 W max.
(Ø 7 mm FM T2) Osram

FINISHES

Matt nickel.



Leuchte zur Anstrahlung von
Bildern, Reflektor 340° drehbar.

LAMPE

- 37 cm: 1x6 W max.
(Ø 7 mm FM T2) Osram
- 47 cm: 1x8 W max.
(Ø 7 mm FM T2) Osram
- 68 cm: 1x13 W max.
(Ø 7 mm FM T2) Osram

OBERFLÄCHE

Nickel matt.

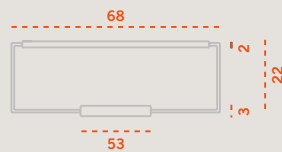
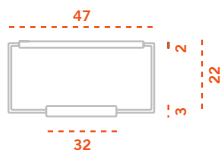
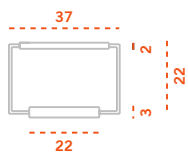
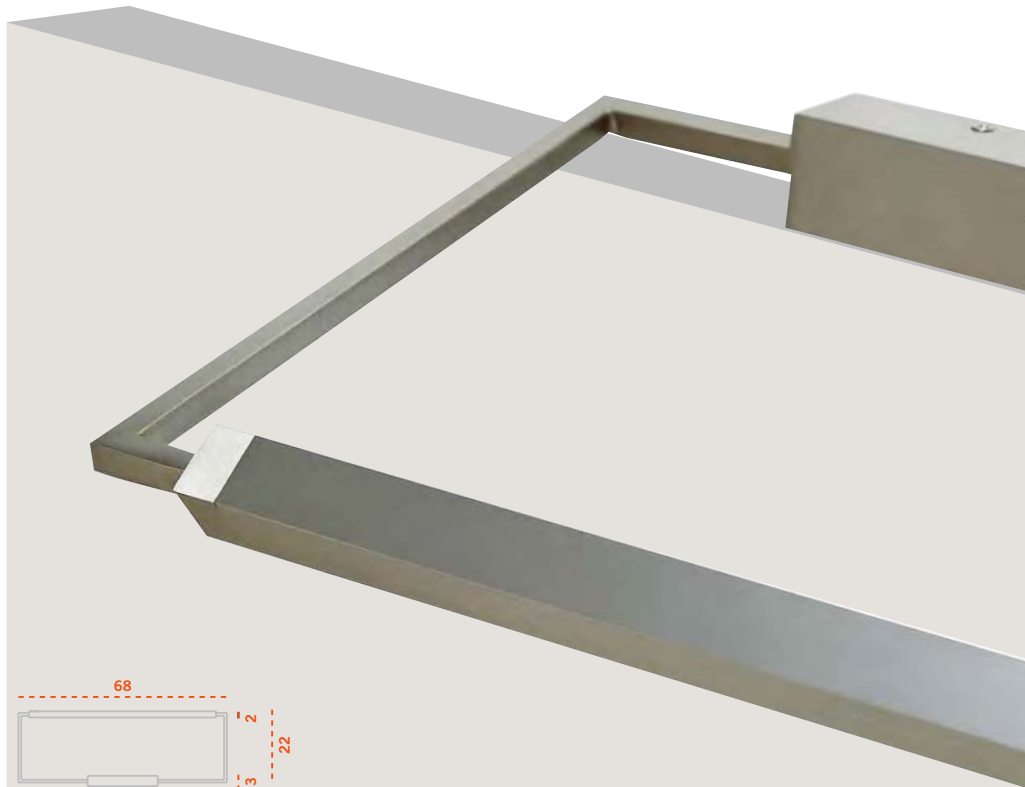

Aplique o plafón metálico en fundición de aluminio. Difusor en metacrilato apto para espacios muy reducidos. Muy fácil de instalar. No se necesita empotrar, es de superficie. Su uso es polivalente tanto como bañador de luz, como de señalización (ver pictogramas standard).

BOMBILLAS

2 posibilidades:

- 1x9 W máx. (GX53).
- 1x1,5W máx. (GX53) LED
Colores LED: rojo, azul, verde, amarillo y blanco.

ACABADOS

Cromo o níquel mate.



Die cast aluminium body wall or ceiling lamp, with a methacrylate diffuser. This product can fit in tight spaces. With no embedded parts, the lamp is surface mounted and very easy to install. Multiple applications as a step light or indication light (see standard pictograms).

BULBS

2 options:

- 1x9 W max. (GX53).
- 1x1,5 W max. (GX53) LED version
Available LED colours: red, blue, green, yellow and white.

FINISHES

Chrome or matt nickel.

Wand- oder Deckenleuchte aus Aluminium Druckguss mit weissem Kunststoff Diffusor. Ideal für kleine und enge Räume, oder als Treppenbeleuchtung. Einfache Aufputz-Montage. Diese Leuchte kann auch als Hinweisleuchte verwendet werden (siehe Standard Piktogramme).

LAMPE

2 Alternativen:

- 1x9 W max. (GX53).
- 1x1,5W max. (GX53) LED
in verschiedenen Farben erhältlich.

OBERFLÄCHE

Chrom oder nickel matt.

Pictogramas / Pictograms / Piktogramme



p. 192

p. 252



MORGAN 45°

DAIFUKU DESIGNS

Aplique metálico en fundición de aluminio. Dimensiones muy reducidas. Apto como bañador de luz. Muy fácil de instalar. No se necesita empotrar, es de superficie.

BOMBILLAS

2 posibilidades:

- 1x9 W máx. (GX53),
bajo consumo.

- 1x1,5 W máx. (GX53) LED
Colores Led: rojo, azul, verde,
amarillo y blanco.

ACABADOS

Cromo o níquel mate.



Die cast aluminium body wall or ceiling lamp. This product can fit in tight spaces. With no embedded parts, the lamp is surface mounted and very easy to install.

BULBS

2 options:

- 1x9 W max. (GX53).

- 1x1,5 W max. (GX53) LED version
Available LED colours: red, blue,
green, yellow and white.

FINISHES

Chrome or matt nickel.

Wand- oder Deckenleuchte aus Aluminium Druckguss. Ideal für kleine und enge Räume, oder als Treppenbeleuchtung. Einfache Aufputz-Montage.

LAMPE

2 Alternativen:

- 1x9 W max. (GX53).

- 1x1,5W max. (GX53) LED
in verschiedenen Farben
erhältlich.

OBERFLÄCHE

Chrom oder nickel matt.





ODYSSEY

GABRIEL TEIXIDÓ

Plafones en cristal óptico,
estructura metálica. Se fabrica en
dos versiones, uno o dos cristales
y dos diámetros cada modelo.

BOMBILLAS

- 1x150 W máx. (E-27)
Incandescente.
- 1x250 W máx. (E-27) Halolux.

ACABADOS

Cromo.

Ceiling light with optical glass,
metallic body. Available in two
versions. One or two glasses shade,
and two diameters in each version.

BULBS

- 1x150 W max. (E-27)
Incandescent.
- 1x250 W max. (E-27) Halolux.

FINISHES

Chrome.

Deckenleuchte mit optischem
Glas und Halterung aus Metall.
Mit einem oder zwei Schirmen,
jeweils in zwei Durchmessern
erhältlich.

LAMPE

- 1x150 W max. (E-27)
Incandescent.
- 1x250 W max. (E-27) Halolux.

OBERFLÄCHE

Chrom.

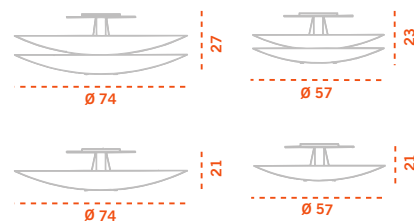



Aplique y plafón metálico.

BOMBILLAS
1x150 W máx. (R7S 80 mm)
Halógeno.

ACABADOS
Cromo.

Metallic wall lamp or ceiling lamp.

BULBS
1x150 W max. (R7S 80 mm)
Halogen.

FINISHES
Chrome.

Wand- oder Deckenleuchte aus
Metall.

LAMPE
1x150 W max. (R7S 80 mm)
Halogen.

OBERFLÄCHE
Chrom.

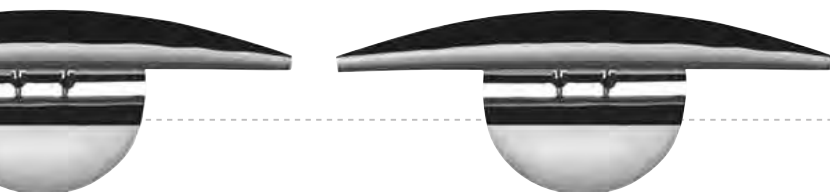

Aplique / wall lamp / wandleuchte

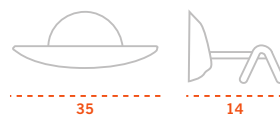

Plafón / ceiling lamp /
deckenleuchte

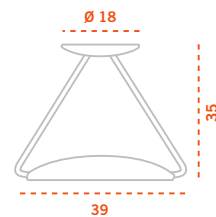



PASCUALINA

PASCUAL SALVADOR

Lámpara pinza metálica con pantalla. Equipada con un cable de 3 m e interruptor en la base. Pinza adaptable hasta 35 mm de grueso. Se fabrica en aplique con interruptor en la base.

BOMBILLAS
1x60 W máx. (E-14)

ACABADOS
Plomo metalizado.
Pantallas: blanca o beige en algodón.

Clip-on and wall lamp with direct and diffused light. Equipped with 3 m of wire and switch on the base itself. Clip can be fit up to 35 mm in thickness. Also available as wall lamp with switch on the base.

BULBS
1x60 W max. (E-14)

FINISHES
Metallic lead.
Shades: cotton fabric in white or beige.

Klemmleuchte aus Metall mit Schirm. Mit drei Meter Kabel und Schalter am Fuß. Klemme lässt sich bis 35 mm Materialstärke montieren. Auch als Wandleuchte mit Schalter am Fuß erhältlich.

LAMPE
1x60 W max. (E-14)

OBERFLÄCHE
Grau-metallic.
Schirm aus Baumwolle: weiß oder beige glatt.



Aplique / wall lamp / wandleuchte

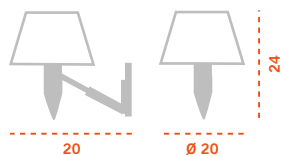

Pinza / clip-on / klemmleuchte

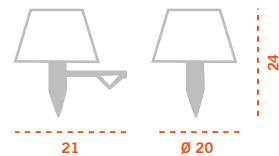



PYTHON

DAIFUKU DESIGNS

Aplique o plafón flexible metálico con bombilla LED. Interruptor en la base.

BOMBILLA

1,4 W. 45 lumen. Color blanco (6000 K). Ángulo de apertura 60°.

ACABADOS

Níquel mate.



Metallic wall or ceiling lamp with LED bulb. Switch on the base.

BULBS

1,4 W. 45 lumen. White colour (6000 K). 60° lighting angle.

FINISHES

Matt nickel.

Decken- oder Wandleuchte mit Metall-Flexschlauch und LED-Lampe. Schalter im Fuß integriert.

LAMPE

1,4 W. 45 lumen. Lichtfarbe neutralweiß (6000 K). Ausstrahlungswinkel 60°.

OBERFLÄCHE

Nickel matt.



VENTAJAS DEL LED

- Consumo mínimo.
- Luz concentrada.
- Calor inexistente.
- Permite una gran calidad de lectura al usuario sin emisión de UV.
- Duración LED aproximadamente 100.000 horas.

ADVANTAGES OF LED

- Low energy.
- Focused light.
- Unappreciable heat.
- Allows the user to have a high quality light for reading without any UV emission.
- LED lifespan: aprox. 100.000 hours.

VORTEILE DER LED

- Geringer Energieverbrauch.
- Gerichtetes Licht.
- Keine Hitzeentwicklung.
- Qualitatives Licht ohne UV Emission.
- Lebensdauer ca. 100.000 Stunden.

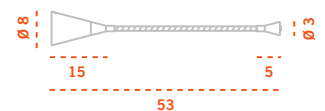



PYTHON

DAIFUKU DESIGNS



Lámpara sobremesa o pinza metálica con bombilla LED. Interruptor en la base. Apertura de la pinza 5,5 cm.

BOMBILLA

1,4 W. 45 lumen. Color blanco (6000 K). Ángulo de apertura 60°.

ACABADOS

Níquel mate.

Metallic table lamp or clip-on lamp (5,5 cm opening) with LED bulb. Switch on the base.

BULBS

1,4 W. 45 lumen. White colour (6000 K). 60° lighting angle.

FINISHES

Matt nickel.

Tischleuchte oder Klemmleuchte mit Metall-Flexschlauch und LED-Lampe. Schalter im Fuß integriert.

LAMPE

1,4 W. 45 lumen. Lichtfarbe neutralweiß (6000 K). Ausstrahlungswinkel 60°.

OBERFLÄCHE

Nickel matt.

VENTAJAS DEL LED

- Consumo mínimo.
- Luz concentrada.
- Calor inexistente.
- Permite una gran calidad de lectura al usuario sin emisión de UV.
- Duración LED aproximadamente 100.000 horas.

ADVANTAGES OF LED

- Low energy.
- Focused light.
- Unappreciable heat.
- Allows the user to have a high quality light for reading without any UV emission.
- LED lifespan: aprox. 100.000 hours.

VORTEILE DER LED

- Geringer Energieverbrauch.
- Gerichtetes Licht.
- Keine Hitzeentwicklung.
- Qualitatives Licht ohne UV Emission.
- Lebensdauer ca. 100.000 Stunden.



p.201

Sobremesa / table lamp / tischleuchte

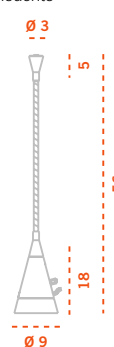

Pinza / clip-on / klemmleuchte

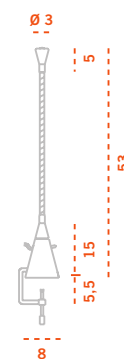



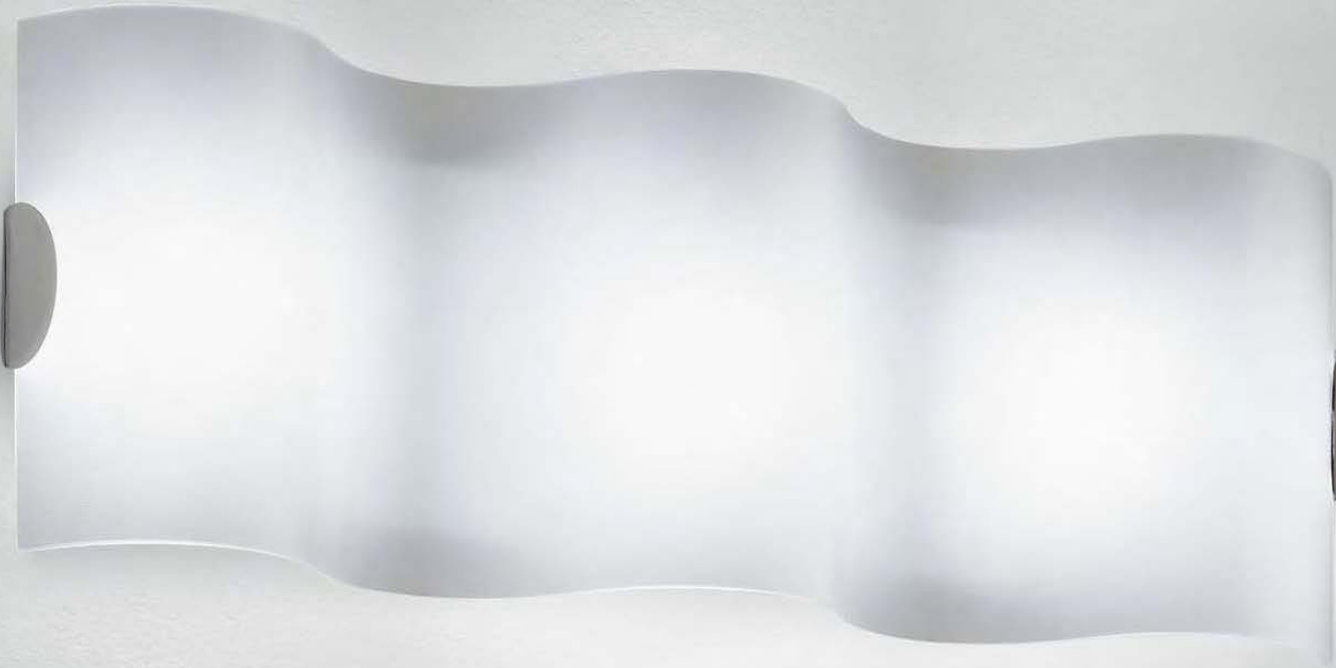

Appliques en cristal curvado grabado mate. Se fabrica en dos medidas.

BOMBILLAS

- Ris 2:
2x60 W máx. (E-14)
2x5-7-9 W máx. (G23)
- Ris 3:
3x60 W máx. (E-14)
3x5-7-9 W máx. (G23)

ACABADOS

Cromo, oro y plomo metalizado.

Wall sconce with a wavy frosted and engraved glass. Available in two sizes.

BULBS

- Ris 2:
2x60 W max. (E-14)
2x5-7-9 W max. (G23)
- Ris 3:
3x60 W max. (E-14)
3x5-7-9 W max. (G23)

FINISHES

Polished chrome, gold or metallic lead.

Wandleuchte mit gebogenem, mattiertem Glasschirm. In drei Größen erhältlich.

LAMPE

- Ris 2:
2x60 W max. (E-14)
2x5-7-9 W max. (G23)
- Ris 3:
3x60 W max. (E-14)
3x5-7-9 W max. (G23)

OBERFLÄCHE

Chrom, gold oder grau-metallic.



RIS 2



RIS 3

RIS 2



RIS 3



RIS 2, RIS 3



Plafón o aplique metálico cristal curvado mate. Se fabrica en tres medidas.

BOMBILLAS

- Mini Ø 21 cm:
1x100 W máx. (R7S 80 mm)
- Mediano Ø 30 cm:
1x150 W máx. (R7S 80 mm)
- Grande Ø 45 cm:
1x150 W máx. (R7S 80 mm)

ACABADOS

Cromo y plomo metalizado.

Metallic halogen wall and ceiling lamp. Glass opaque bend. Available in three sizes.

BULBS

- Mini Ø 21 cm:
1x100 W max. (R7S 80 mm)
- Medium Ø 30 cm:
1x150 W max. (R7S 80 mm)
- Large Ø 45 cm:
1x150 W max. (R7S 80 mm)

FINISHES

Chrome and metallic lead.

Wand- oder Deckenleuchte aus Metall mit gebogenem, mattiertem Glasschirm. In drei Größen erhältlich.

LAMPE

- Klein, 21 cm Durchmesser:
1x100 W max. (R7S 80 mm)
- Medium, 30 cm Durchmesser:
1x150 W max. (R7S 80 mm)
- Groß, 45 cm Durchmesser:
1x150 W max. (R7S 80 mm)

OBERFLÄCHE

Chrom oder grau-metallic.

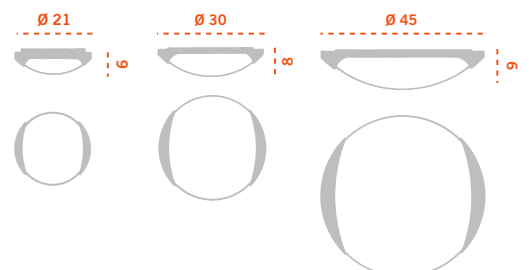

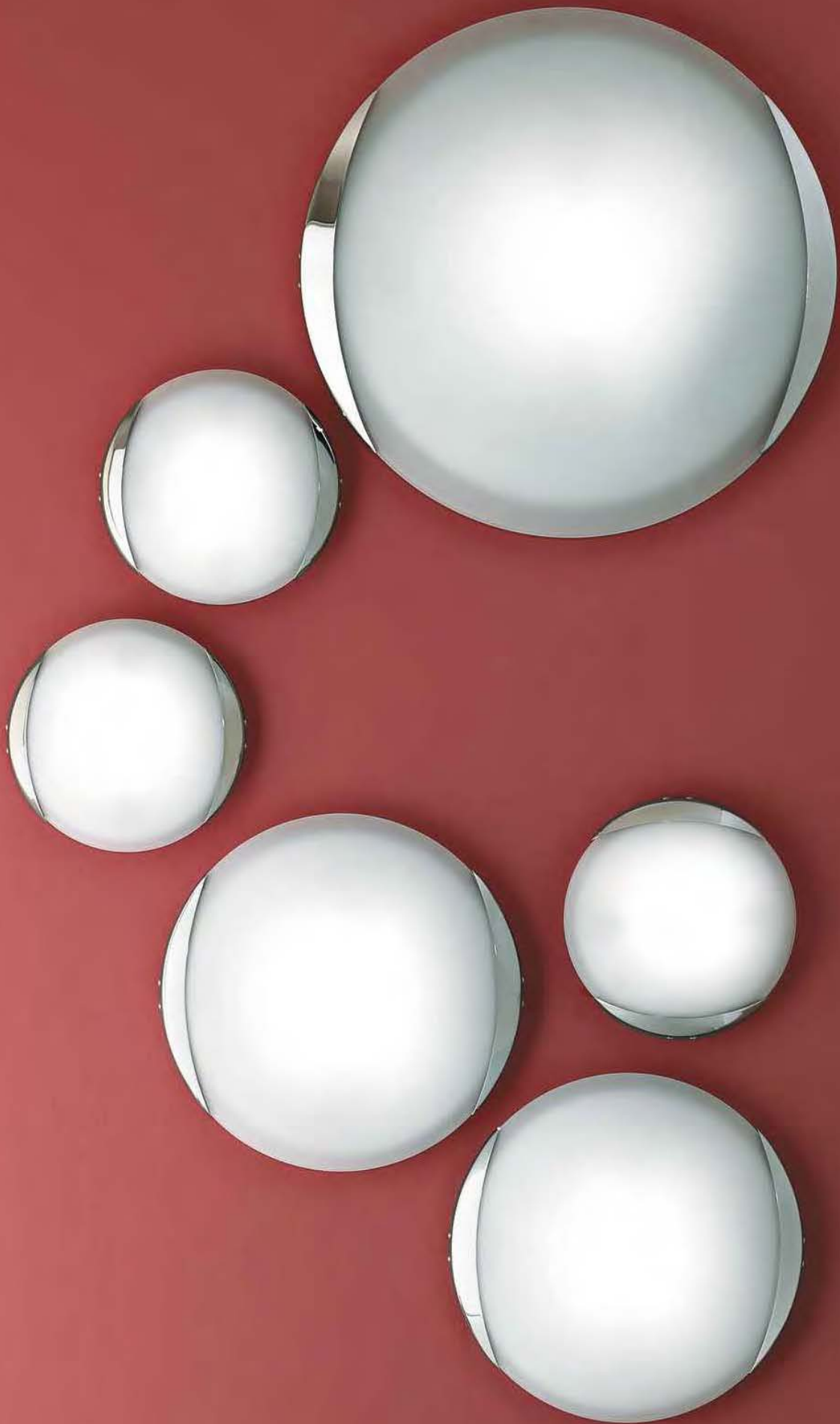

SCOTT
GABRIEL TEIXIDÓ



Plafones metálicos con cristal opal blanco. Se fabrican en dos medidas.

BOMBILLAS

- Mini:
1x60 W máx. (E-14)
- Grande:
1x100 W máx. (E-27)

ACABADOS

Cromo.

Metallic ceiling lamps with white opal glass. Available in two sizes.

BULBS

- Mini:
1x60 W max. (E-14)
- Large:
1x100 W max. (E-27)

FINISHES

Chrome.

Deckenleuchte aus Metall und weißem Opalglas. In zwei Größen erhältlich.

LAMPE

- Klein:
1x60 W max. (E-14)
- Groß:
1x100 W max. (E-27)

OBERFLÄCHE

Chrom.

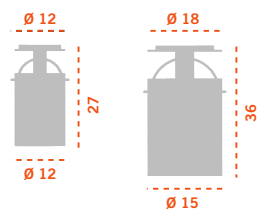

p. 124

Aplique metálico flexible con bombilla LED. Interruptor en la base.

BOMBILLAS
4,2 W. 180 Lumen (5.000 K).
Apertura de ángulo 90°.

ACABADOS
Cromo y níquel mate.

Metallic flexible wall lamp with LED bulb. Switch on the base.

BULBS
4,2 W. 180 Lumen (5.000 K).
90° lighting angle.

FINISHES
Chrome and matt nickel.

Wandleuchte mit Metall-Flexschlauch und LED Lampe. Schalter im Fuß integriert.

LAMPE
4,2 W. 180 Lumen (5.000 K).
Ausstrahlungswinkel 90°.

OBERFLÄCHE
Chrom oder nickel matt.

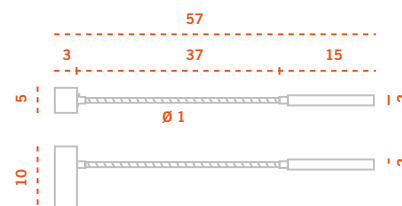
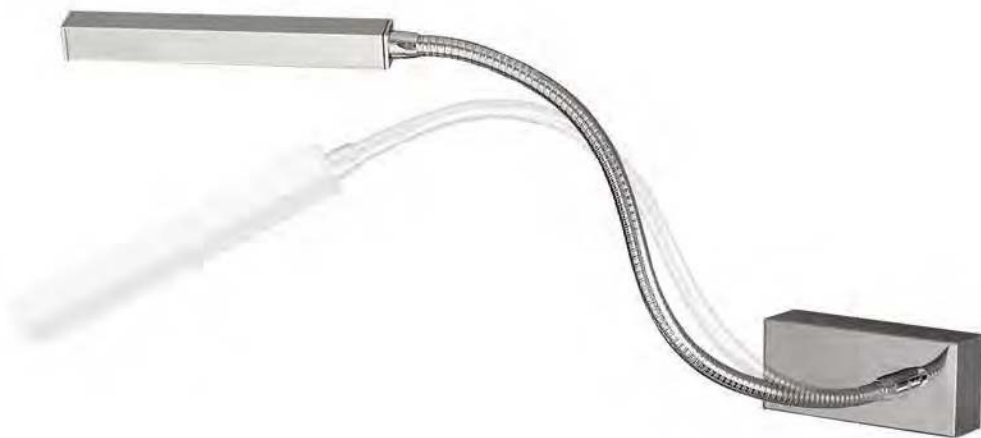





Plafón o aplique metálico con rejilla gris. Cuerpo en polietileno y marco en extrusión de aluminio anodizado.

BOMBILLAS
1x30 W máx. (GE lighting GRZ-10t) bajo consumo.

ACABADOS
Anodizado gris natural.

Metallic ceiling or wall lamp with grey grill. Body made of polyethylene and frame in extruded anodized aluminium.

BULBS
1x30 W max. (GE lighting GRZ-10t) low energy.

FINISHES
Anodized natural grey.

Decken- oder Wandleuchte mit grauem Gitter, Leuchtenkörper aus Polyäthylen und Rahmen aus eloxiertem Aluminium.

LAMPE
1x30 W max. Kompaktleuchtstofflampe GRZ-10t (GE lighting).

OBBERFLÄCHE
Grau eloxiert.

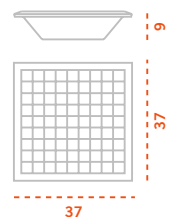

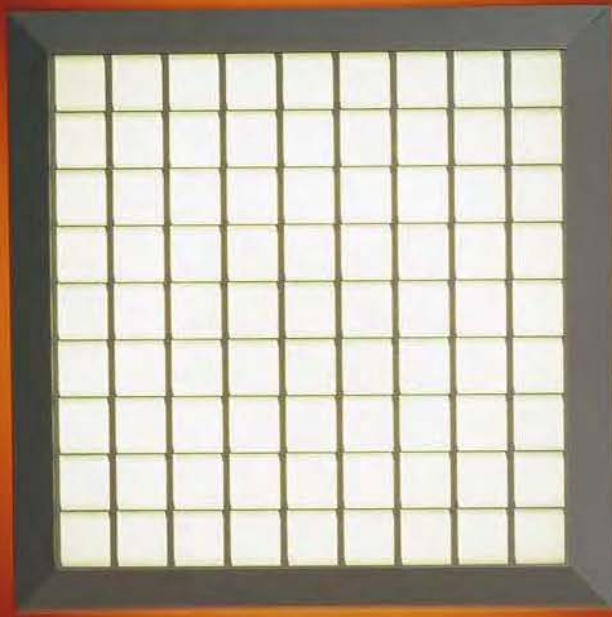

SUNSET

GABRIEL TEIXIDÓ

Plafón o aplique metálico con cristal decorado mate.

BOMBILLAS
1x150 W máx. (R7S 80 mm)
Halógeno.

ACABADOS
Cromo.

Metallic wall and ceiling lamp.
Glass opaque decorated.

BULBS
1x150 W max. (R7S 80 mm)
Halogen.

FINISHES
Chrome.

Decken- oder Wandleuchte aus
Metall und mattiertem Glas.

LAMPE
1x150 W max. (R7S 80 mm)
Halogen.

OBERFLÄCHE
Chrom.





Plafones en tres formas de cristal plano mate templado.

BOMBILLAS
1x200 W máx. (R7S 118 mm)

ACABADOS
Cromo.

Ceiling lamp in three types of flat, toughened matt glass.

BULBS
1x200 W max. (R7S 118 mm)

FINISHES
Chrome.

Deckenleuchte mit leicht mattierter Glasabdeckung. In drei Formen erhältlich.

LAMPE
1x200 W max. (R7S 118 mm)

OBERFLÄCHE
Chrom.

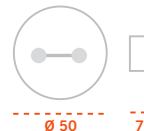
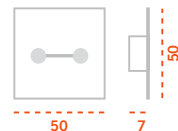
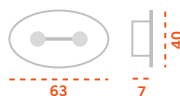



Apliques en aluminio y cristal opal blanco. Se puede colocar en vertical u horizontal. Se fabrica en dos medidas.

BOMBILLAS

- 32 cm: 1x150 W máx. (R7S 118 mm)
- 45 cm: 1x 24 W máx. (TC-L2G11 bajo consumo)

ACABADOS

Negro, blanco y gris metalizado.

Metallic wall lamp in aluminium with white opal glass. Can be mounted vertically or horizontally. Available in two sizes.

BULBS

- 32 cm: 1x150 W max. (R7S 118 mm)
- 45 cm: 1x 24 W max. (TC-L2G11 low energy)

FINISHES

Black, white and metallic grey.

Wandleuchte aus Aluminium mit opalweißem Glas. Vertikale und horizontale Montage möglich. In zwei Größen erhältlich.

LAMPE

- 32 cm: 1x150 W max. (R7S 118 mm)
- 45 cm: 1x 24 W max. (TC-L2G11 Kompaktleuchtstofflampe)

OBERFLÄCHE

Schwarz, weiß oder grau-metallic.

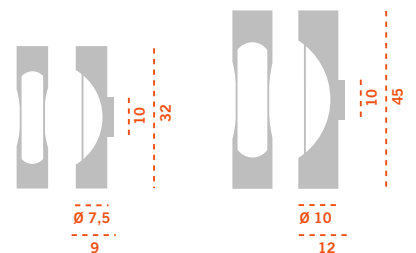



VALENTINA

GABRIEL TEIXIDÓ

Aplique metálico con reflector giratorio 95°.

BOMBILLAS
1x300 W máx. (R7S 118 mm)

ACABADOS
Plomo metalizado.

Metallic wall lamp reflector rotates 95°.

BULBS
1x300 W max. (R7S 118 mm)

FINISHES
Metallic lead.

Wandleuchte aus Metall mit 95°
schwenkbarem Reflektor.

LAMPE
1x300 W max. (R7S 118 mm)

OBERFLÄCHE
Grau-metallic.



ILLO





Aplique o plafón flexible metálico con reflector de plástico óptico transparente.

BOMBILLAS
1x30 W máx.
(E-14 reflector 39 mm)

ACABADOS
Níquel mate.

Flexible metallic ceiling or wall lamp with optical transparent plastic reflector.

BULBS
1x30 W max. Incandescent
(E-14 reflector 39 mm)

FINISHES
Matt nickel.

Decken-oder Wandleuchte mit Metall-Flexschlauch und transparentem Kunststoffreflektor.

LAMPE
1x30 W max. (E-14 R39)

OBERFLÄCHE
Nickel matt.



p.224

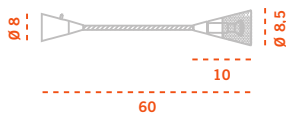



VIPER

DAIFUKU DESIGNS



Lámpara pinza metálica con reflector de plástico óptico transparente e interruptor en la base. Apertura de pinza: 5,5 cm.

BOMBILLAS

1x30 W máx.

(E-14 reflector 39 mm)

ACABADOS

Níquel mate.

Metallic clip-on lamp (5,5 cm opening) with a transparent optical plastic reflector and a switch on the base.

BULBS

1x30 W max. Incandescent

(E-14 reflector 39 mm)

FINISHES

Matt nickel.

Klemmleuchte mit Metall-Flexschlauch und transparentem Kunststoffreflektor (Klemmöffnung max. 5,5 cm). Schalter integriert.

LAMPE

1x30 W max. (E-14 R39)

OBERFLÄCHE

Nickel matt.

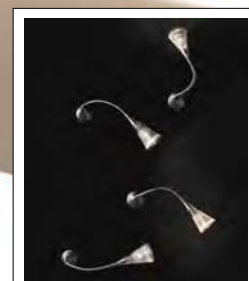
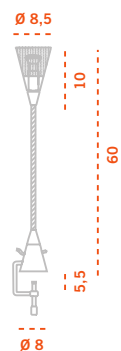

p. 222

Plafón metálico con reflector de plástico óptico transparente.

BOMBILLAS
1x50 W máx. PAR 16 (E-14)
Halógena.

ACABADOS
Níquel mate.

Metallic ceiling lamp with optical transparent plastic reflector.

BULBS
1x50 W max. PAR 16 (E-14)
Halogen.

FINISHES
Matt nickel.

Deckenleuchte aus Metall mit transparentem Kunststoffreflektor.

LAMPE
1x50 W max. PAR 16 (E-14)
Halogen.

OBERFLÄCHE
Nickel matt.



p.228

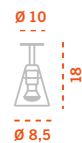





Aplique metálico con reflector de plástico óptico transparente.

BOMBILLAS
1x50 W máx. PAR 16 (E-14)
Halógena.

ACABADOS
Níquel mate.

Metallic wall lamp with optical transparent plastic reflector.

BULBS
1x50 W max. PAR 16 (E-14)
Halogen.

FINISHES
Matt nickel.

Wandleuchte aus Metall und transparentem Kunststoffreflektor.

LAMPE
1x50 W max. PAR 16 (E-14)
Halogen.

OBERFLÄCHE
Nickel matt.

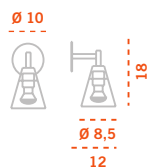

p. 226



Plafón o aplique metálico con cristal opal blanco, la versión individual se fábrica en dos medidas. Únicamente la versión pequeña se fábrica con regleta dos o tres cristales que pueden ser usados tanto vertical como horizontal.

BOMBILLAS

- 11 cm:
1x60 W máx. (E-14)
- 17 cm:
1x100 W máx. (E-27)

ACABADOS

Individual: cromo.
Regletas: acero inoxidable.

Metallic ceiling or wall lamp with white opal glass. The individual version is available in two sizes. Only the small size lamp can be installed on the track of 2 or 3 lights, which can be mounted vertically or horizontally.

BULBS

- 11 cm:
1x60 W max. (E-14)
- 17 cm:
1x100 W max. (E-27)

FINISHES

Individual: chrome.
Track: stainless steel.

Decken- oder Wandleuchte mit Metallfuß und opalweißem Glas. Einzelleuchte in 2 verschiedenen Durchmessern, kleine Version auch als 2- oder 3-fach Leuchte lieferbar. Für vertikale und horizontale Montage geeignet.

LAMPE

- 11 cm:
1x60 W max. (E-14)
- 17 cm:
1x100 W max. (E-27)

OBERFLÄCHE

Gehäuse Einzelleuchte: chrom.
Gehäuse 2/3-fach Leuchte: edelstahl.
Glas: opalweiß.

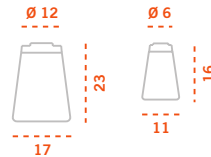

Regleta / track / schiene (WAKI 11 cm)

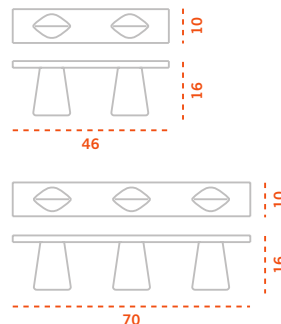



Aplique metálico en dos medidas con pantalla en policarbonato blanco.

BOMBILLAS
1x100 W máx. (E-27)
2x7-9 W máx. (G23)

ACABADOS
Plomo metalizado.

Metallic wall light, available in two sizes. With polycarbonate white shade.

BULBS
1x100 W max. (E-27)
2x7-9 W max. (G23)

FINISHES
Metallic lead.

Wandleuchte aus Metall in zwei Größen, mit Schirm aus weißem Polycarbonat.

LAMPE
1x100 W max. (E-27)
2x7-9 W max. (G23)

OBERFLÄCHE
Grau-metallic.

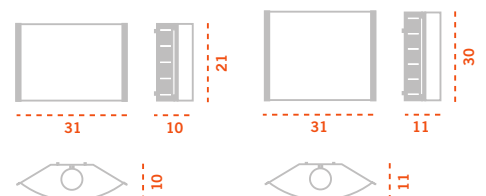
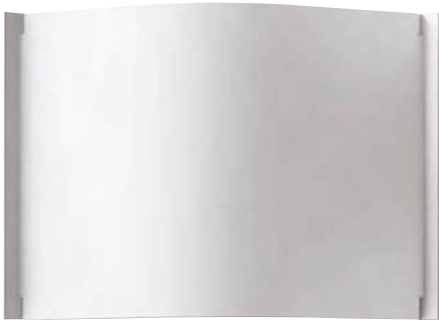



HARRYLITEBOXLITECUBE
MORGAN45°OUTSIDE
RONDO

EXTERIOR
OUTDOOR
AUBENLEUCHTEN

HARRY

PORCUATRO



Lámpara pie suelo exterior e interior. Aplicable a mesas de jardín y terrazas. Se fabrica en versión para fijarla en la tierra, y como luz de ambiente exterior. Equipada con cable 9 metros.

BOMBILLAS
1x25 W máx. (E-27 bajo consumo)

ACABADOS
Pincho de acero inoxidable.
Pantalla: polietileno blanco.
Base pie: titanio, blanco y naranja.

Floor lamp designed for indoor and outdoor use. Also adapted for garden tables and terraces. Can be put directly into the ground or as auxiliary outdoor light. Equipped with 9 m of cable.

BULBS
1x25 W max. (E-27 low energy)

FINISHES
Spike in stainless steel.
Lampshade: white polyethylene.
Foot base: titanium, white and orange.

Stehleuchte für den Innen- und Außenraum. Der Leuchtenfuß ist als Erdspieß zum Einstecken in das Erdreich ausgebildet. Kabellänge 9 Meter. Als Zubehör ist ein Standfuß lieferbar.

LAMPE
1x25 W max.
(Kompaktleuchtstofflampe E-27)

OBERFLÄCHE
Leuchtenfuß: Edelstahl.
Lampenschirm: Polyethylen opalweiß.
Standfuß: metall / farbe titan, weiß oder orange.



Apto exteriores, IP 64.
For outdoor use, IP 64.
Für Außenanwendung, IP 64.



SELECCIÓN DELTA
ADI-FAD 2005



HARRY

PORCUATRO



p.240

p.242

p.244

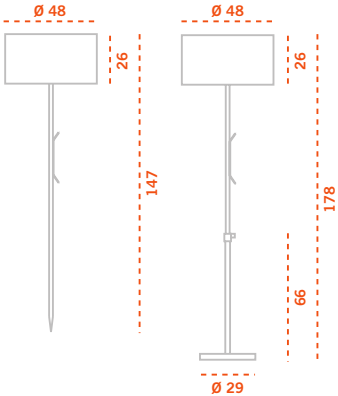



HARRY JARDÍN

PORCUATRO

Lámpara preparada para exterior, aplicable a terrazas y jardines. La base es metálica zincada, la cual permite enrollar el cable sobrante que no utilizemos. Equipada con cable 9 metros.

BOMBILLAS
1x25 W máx. (E-27 bajo consumo)

ACABADOS
Pantalla: polietileno blanco.

Lamp designed for outdoor use, adapted for garden tables and terraces. The zinc plated metal base permits coiling the leftover cable. Equipped with 9 m of cable.

BULBS
1x25 W max. (E-27 low energy)

FINISHES
Lampshade: white polyethylene.

Bodenleuchte für den Innen- und Außenraum. Kabel aufrollbar. Kabellänge 9 Meter.

LAMPE
1x25 W max.
(Kompaktleuchtstofflampe E-27)

OBERFLÄCHE
Lampenschirm: Polyethylen opalweiß.



Apto exteriores, IP 64.
For outdoor use, IP 64.
Für Außenanwendung, IP 64.



p. 238

p. 242

p. 244





HARRY

PORCUATRO



Plafón preparado para exterior.

BOMBILLAS

1x25 W máx. (E-27 bajo consumo)

ACABADOS

Pantalla: polietileno blanco.

Ceiling lamp designed for outdoor use.

BULBS

1x25 W max. (E-27 low energy)

FINISHES

Lampshade: white polyethylene.

Deckenleuchte für den Innen- und Außenraum.

LAMPE

1x25 W max.

(Kompaktleuchtstofflampe E-27)

OBERFLÄCHE

Lampenschirm: Polyethylen opalweiß.



Apto exteriores, IP 64.

For outdoor use, IP 64.

Für Außenanwendung, IP 64.

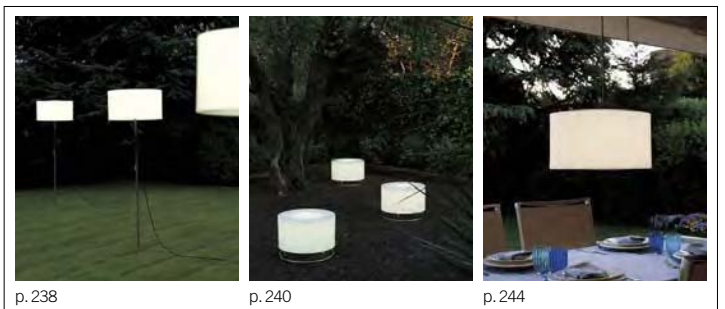
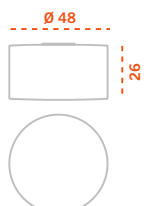

HARRY
PORCUATRO



Colgante preparado para exterior muy fácil de instalar, contiene un cable de sujeción regulable que permite colocarlo en cualquier techo. Aplicable a mesas de jardín y terrazas. Equipado con cable eléctrico de 9 m.

BOMBILLAS

1x25 W máx. (E-27 bajo consumo)

ACABADOS

Pantalla: polietileno blanco.

Suspension lamp designed for outdoor use, very easy to install thanks to its adjustable cable which allows to install it on any ceiling. Also adapted for garden tables and terraces. Equipped with 9 m of electric cable.

BULBS

1x25 W max. (E-27 low energy)

FINISHES

Lampshade: white polyethylene.

Pendelleuchte für den Innen- und Außenraum. Einfachste Montage aufgrund justierbarem-Kabel mit einer Gesamtlänge von 9 m.

LAMPE

1x25 W max.

(Kompaktleuchtstofflampe E-27)

OBERFLÄCHE

Lampenschirm: Polyethylen opalweiß.



Apto exteriores, IP 64.
For outdoor use, IP 64.
Für Außenanwendung, IP 64.

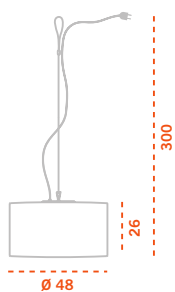

p. 238

p. 240

p. 242

LITE BOX, LITE CUBE

DAIFUKU DESIGNS





LITE BOX, LITE CUBE

DAIFUKU DESIGNS

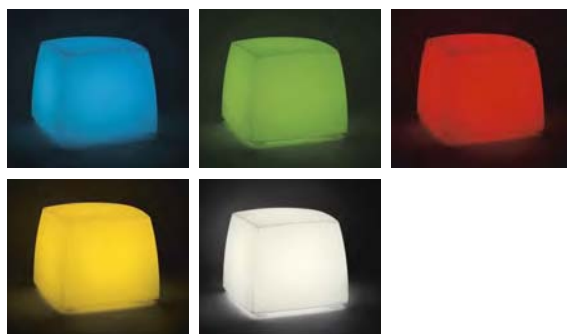

Lámparas-asientos en polietileno blanco. Aptos para exterior e interior. Aplicable para terrazas y jardines. Equipados con cable 9 m.

BOMBILLAS*

- LITE CUBE: 1x7 W máx. (E-27 bajo consumo).
- LITE BOX: 4x7 W máx. (E-27 bajo consumo).

*Colores: blanco (cálido 2700° K), rojo, verde, amarillo y azul.

ACABADOS

Polietileno blanco.

Lights-seats in white polyethylene designed for indoor and outdoor use, adapted for gardens and terraces. Equipped with 9 m of cable.

BULBS*

- LITE CUBE: 1x7 W max. (E-27 low energy).
- LITE BOX: 4x7 W max. (E-27 low energy).

*Colours: white (warm 2700° K), red, green, yellow and blue.

FINISHES

White polyethylene.

Sitzhocker und Bodenleuchte für den Innen- und Aussenraum. Kabellänge 9 Meter.

LAMPE*

- LITE CUBE: 1x7 W max. (Kompakleuchtstoff- lampe E-27).
- LITE BOX: 4x7 W max. (Kompakleuchtstofflampe E-27).

*Lichtfarbe: weiß (warm 2700° K), rot, grün, gelb oder blau nach Wahl.

OBERFLÄCHE

Polyethylen opalweiß.



Apto exteriores.
For outdoor use.
Für Außenanwendung.

LITE CUBE: IP 65.
LITE BOX: IP 66.

LITE CUBE

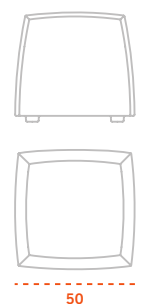

LITE BOX

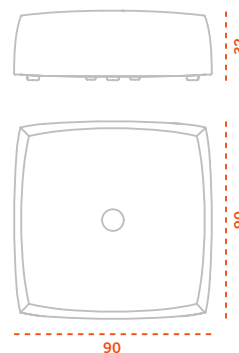



LITE BOX, LITE CUBE

DAIFUKU DESIGNS



Asientos en polietileno blanco.
Aptos para exterior e interior.
Aplicable para terrazas y jardines.

ACABADOS
Polietileno blanco.

Seats in white polyethylene
designed for indoor and outdoor
use, adapted for gardens and
terraces.

FINISHES
White polyethylene.

Sitzhocker aus Polyethylen für den
Innen- und Aussenraum, zur
Nutzung im Garten und auf der
Terrasse.

OBERFLÄCHE
Polyethylen opalweiß.



Apto exteriores.
For outdoor use.
Für Außenanwendung.

SIN LUZ

WITHOUT LIGHT / OHNE LEUCHTEINHEIT



LITE CUBE

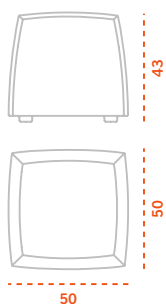

LITE BOX

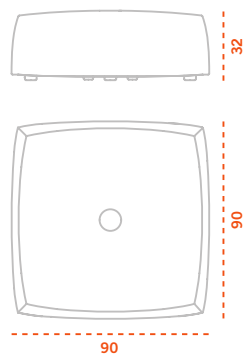

MORGAN 45° OUTSIDE

DAIFUKU DESIGNS



Aplicque metálico en fundición de aluminio. Dimensiones muy reducidas. Apto como bañador de luz. Muy fácil de instalar. No se necesita empotrar, es de superficie.

BOMBILLAS

2 posibilidades:

- 1x9 W máx. (GX53),

bajo consumo.

- 1x1,5 W máx. (GX53) LED

Colores Led: rojo, azul, verde, amarillo y blanco.

ACABADOS

Gris.

Die cast aluminium body wall or ceiling lamp. This product can fit in tight spaces. With no embedded parts, the lamp is surface mounted and very easy to install.

BULBS

2 options:

- 1x9 W max. (GX53).

- 1x1,5 W max. (GX53) LED version

Available LED colours: red, blue, green, yellow and white.

FINISHES

Grey.

Wand- oder Deckenleuchte aus Aluminium Druckguss. Ideal für kleine und enge Räume, oder als Treppenbeleuchtung. Einfache Aufputz-Montage.

LAMPE

2 Alternativen:

- 1x9 W max. (GX53).

- 1x1,5W max. (GX53) LED

in verschiedenen Farben erhältlich.

OBERFLÄCHE

Grau.



Apto exteriores, IP 64.

For outdoor use, IP 64.

Für Außenanwendung, IP 64.

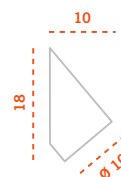





Plafón o aplique metálico en aluminio. Difusor de cristal matizado interiormente.

BOMBILLAS
1x75 W máx. (E-27)
1x18 W máx. (G24 D2)

ACABADOS
Blanco y gris metalizado.

Metallic ceiling or wall lamp in aluminium. Glass diffuser with interior frosting.

BULBS
1x75 W max. (E-27)
1x18 W max. (G24 D2)

FINISHES
White and metallic grey.

Wand- oder Deckenleuchte aus Aluminium mit innen mattiertem Glasschirm.

LAMPE
1x75 W max. (E-27)
1x18 W max. (G24 D2)

OBERFLÄCHE
Weiß oder grau-metallic.



Apto exteriores, IP 54.
For outdoor use, IP 54.
Für Außenanwendung, IP 54.

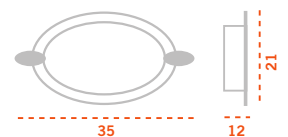





Plafón o aplique metálico en aluminio. Difusor de cristal matizado interiormente.

BOMBILLAS
1x75 W máx. (E-27)
2x7-9 W máx. (G23)

ACABADOS
Blanco y gris metalizado.

Metallic ceiling or wall lamp in aluminium. Glass diffuser with interior frosting.

BULBS
1x75 W max. (E-27)
2x7-9 W max. (G23)

FINISHES
White and metallic grey.

Wand- oder Deckenleuchte aus Aluminium. Mit innen mattiertem Glasschirm.

LAMPE
1x75 W max. (E-27)
2x7-9 W max. (G23)

OBERFLÄCHE
Weiß oder grau-metallic.



Apto exteriores, IP 54.
For outdoor use, IP 54.
Für Außenanwendung, IP 54.

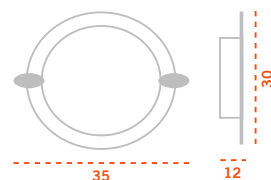



AITAAITANAALADINAALFA
ÁREAATENEAUGUSTA
AURAAURITABARCINO
BASICBERTABOXSTER
CANDELCITYCÓNICA
DIALDOUGLASFINGER
FLASHFLEXIAFOCUS
FOCUSMINIFRIDAFRITZ
FUNIGALAGALILEA
GALLERYGAMMAGILDA
HAMILTONHANSHARRYHI-FI
HOTELHOTEL-PYTHON
INFINITIIRMAJACKYJAPAN
KEOPSKIWILITEBOX
LITECUBEMASTERMAX
MERCURYMETROPOLMIA
MINIMISSSHANGAI
MONDRIANMORGAN
MORGAN45°

MORGAN45°OUTSIDE
NAIROBINAOMINICK
NIRVANAODYSSSEYORLY
OVALPASCUALINAPETRA
POPPYPOPPYTEALIGHT
PYTHONRISRITAROBINSON
RONDOSCOTTSIGNORA
SQUARESNAIKSUITE
SUNSETTEMATOMMYTOP
TOTORAUDONVALENTINA
VIPERVIPSWAKIZENIT

**SOBREMESAS
TABLE LAMPS
TISCHLEUCHTEN**



AITA
12



AITANA
14



ALADINA
16



AURA
18



AURITA
20



CANDEL
22



CITY
24



CITY
26



DOUGLAS
28



GALA
30



GALILEA MINI
32



GALILEA SOBREMESA
34



GILDA
36



JAPAN
38



MASTER
40



NAIROBI
42



NAOMI MINI
44



NAOMI
44



NAOMI
46



NIRVANA MINI
48



NIRVANA
50



NIRVANA
52



POPPY
54



POPPY TEALIGHT
56



PYTHON
202



TEMA
58

**PINZAS
CLIP-ON LAMPS
KLEMMLEUCHTEN**



CITY
26



HI-FI
170



PASCUALINA
198



PYTHON
202



VIPER
224

Medidas en cm.
All measures in cm.
Maße in cm.

**PIE SUELO
FLOOR LAMPS
STEHLEUCHTEN**



AITANA
62



ALADINA
16



ATENEA
64



AUGUSTA
66



AURA
68



BARCINO
70



CITY
72



CÓNICA
74



DOUGLAS
28



GALA
76



GALILEA
78



HARRY
236



HARRY JARDÍN
240



LITE BOX
246

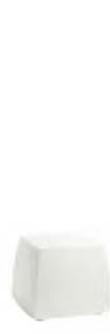

LITE CUBE
246



MIA
80



MISS SHANGAI
82



NAOMI
84



NIRVANA
86



SIGNORA
88



TEMA
90



TOTORA
92



TRIA HALÓGENA
94

**COLGANTES
SUSPENSION LAMPS
PENDELLEUCHTEN**



AITANA
98



AURA
100



FINGER
102



FLEXIA
104



FRIDA
108



FUNI
110

**COLGANTES
SUSPENSION LAMPS
PENDELLEUCHTEN**



HARRY
244



IRMA
112



MAX
114



METROPOL
116



NICK
118



PETRA
120



ROBINSON
122



SCOTT
124



TOMMY
126

**APLIQUES
WALL LAMPS
WANDELEUCHTEN**



ALFA
130



ÁREA
132



AURA
134



BARCINO
136



BASIC
138



BERTA
140



BOXSTER
142



CITY
144



DIAL
146



FLASH
148



FLEXIA
150



FLEXIA
152



FOCUS
154



FOCUS MINI
155



FRITZ
156



GALA
158



GALA MINI
158



GAMMA
130



GILDA
162



HAMILTON
164



HANS
166

**APLIQUES
WALL LAMPS
WANDLEUCHTEN**



HANS CUADRADO
168



HOTEL
172



HOTEL-PYTHON
174



INFINITI
176



JACKY
178



KEOPS
180



KIWI
182



MERCURY
184



MERCURY
184



MINI
186



MORGAN
190



MORGAN 45°
192



MORGAN 45° OUTSIDE
252



ORLY
196



OVAL
254



PASCUALINA
198



PYTHON
200



RIS
204



RITA
206



RONDO
256



SNAIK
210



SQUARE
212



SUITE
140



SUNSET
214



UDON
218



VALENTINA
220



VIPER
222



VIPS
228



WAKI
230



WAKI
230



ZÉNIT
232



**APLIQUES CUADROS
PICTURE LAMPS
BILDERLEUCHTEN**



GALLERY
160



MONDRIAN
188

**FOCOS
SPOTLIGHTS
STRAHLER**



DIAL
146



FLASH
148



FOCUS
154



FOCUS MINI
155

**PLAFONES
CEILING LAMPS
DECKENLEUCHTEN**



BASIC
138



BOXSTER
142



DIAL
146



FLASH
148



FOCUS
154



FOCUS MINI
155



FRITZ
156



HAMILTON
164



HARRY
242



JACKY
178



KEOPS
180



KIWI
182



MINI
186



ODYSSEY
194



ORLY
196



OVAL
254



PYTHON
200



RITA
206



RONDO
256



SCOTT
208



SQUARE
212



SUNSET
214



TOP
216



VIPER
222



VIPS
226



WAKI
230



**EXTERIOR
OUTDOOR
AUßENLEUCHTEN**



HARRY
236



HARRY JARDÍN
240



HARRY
242



HARRY
244



LITE BOX
246



LITE CUBE
246



MORGAN 45° OUTSIDE
252



OVAL
254



RONDO
256

Medidas en cm.
All measures in cm.
Maße in cm.

A	AITA	12, 13	M	MASTER	40, 41
	AITANA	14, 15, 62, 63, 98, 99		MAX	114, 115
	ALADINA	16, 17		MERCURY	184, 185
	ALFA	130, 131		METROPOL	116, 117
	ÁREA	132, 133		MIA	80, 81
	ATENEA	64, 65		MINI	186, 187
	AUGUSTA	66, 67		MISS SHANGAI	82, 83
	AURA	18, 19, 68, 69, 100, 101, 134, 135		MONDRIAN	188, 189
	AURITA	20, 21		MORGAN	190, 191
B	BARCINO	70, 71, 136, 137		MORGAN 45°	192, 193
	BASIC	138, 139		MORGAN 45° OUTSIDE	252, 253
	BERTA	140, 141	N	NAIROBI	42, 43
	BOXSTER	142, 143		NAOMI	44, 45, 46, 47, 84, 85
C	CANDEL	22, 23		NICK	118, 119
	CITY	24, 25, 26, 27, 72, 73, 144, 145		NIRVANA	48, 49, 50, 51, 52, 53, 86, 87
	CÓNICA	74, 75	O	ODYSSEY	194, 195
D	DIAL	146, 147		ORLY	196, 197
	DOUGLAS	28, 29		OVAL	254, 255
F	FINGER	102, 103	P	PASCUALINA	198, 199
	FLASH	148, 149		PETRA	120, 121
	FLEXIA	104, 105, 106, 107, 150, 151, 152, 153		POPPY	54, 55
	FOCUS	154, 155		POPPY TEALIGHT	56, 57
	FOCUS MINI	154, 155		PYTHON	200, 201, 202, 203
	FRIDA	108, 109	R	RIS	204, 205
	FRITZ	156, 157		RITA	206, 207
	FUNI	110, 111		ROBINSON	122, 123
G	GALA	30, 31, 76, 77, 158, 159		RONDO	256, 257
	GALILEA	32, 33, 34, 35, 78, 79	S	SCOTT	124, 125, 208, 209
	GALLERY	160, 161		SIGNORA	88, 89
	GAMMA	130, 131		SNAIK	210, 211
	GILDA	36, 37, 162, 163		SQUARE	212, 213
H	HAMILTON	164, 165		SUITE	140, 141
	HANS	166, 167, 168, 169		SUNSET	214, 215
	HARRY	236, 237, 238, 239, 240, 241, 242, 243, 244, 245	T	TEMA	58, 59, 90, 91
	HI-FI	170, 171		TOMMY	126, 127
	HOTEL	172, 173		TOP	216, 217
	HOTEL-PYTHON	174, 175		TOTORA	92, 93
I	INFINITI	176, 177		TRIA HALÓGENA	94, 95
	IRMA	112, 113	U	UDON	218, 219
J	JACKY	178, 179	V	VALENTINA	220, 221
	JAPAN	38, 39		VIPER	222, 223, 224, 225
K	KEOPS	180, 181		VIPS	226, 227, 228, 229
	KIWI	182, 183	W	WAKI	230, 231
L	LITE BOX	246, 247, 248, 249, 250, 251	Z	ZÉNIT	232, 233
	LITE CUBE	246, 247, 248, 249, 250, 251			

Carpyen S.L. se reserva el derecho a efectuar modificaciones en las características técnicas y acabados de los productos que se muestran en éste catálogo.
Carpyen S.L. reserve the right to carry out any modification to the technical features and finish of the products displayed in the catalogue without prior notice.
Carpyen S.L. behält sich das Recht vor, Änderungen an Design und Technik der im Katalog abgebildeten Leuchten ohne vorherige Ankündigung durchzuführen.



AGRADECIMIENTOS Corium, Criteri Interiors, Gibernau Plana Asociados, Graó, Grupo Derby Hoteles, Grupo Ruyser, Joquer, Manbar, Mínim, Nani Marquina, Prisma, Versátil, Vinçon

DISEÑO Y DIRECCIÓN DE ARTE Esther Gaya FOTOS Jordi Canosa, Eva González, Santi de Pablo, Carme Masià, Alexis Taulé i Delor

