

FontanaArte

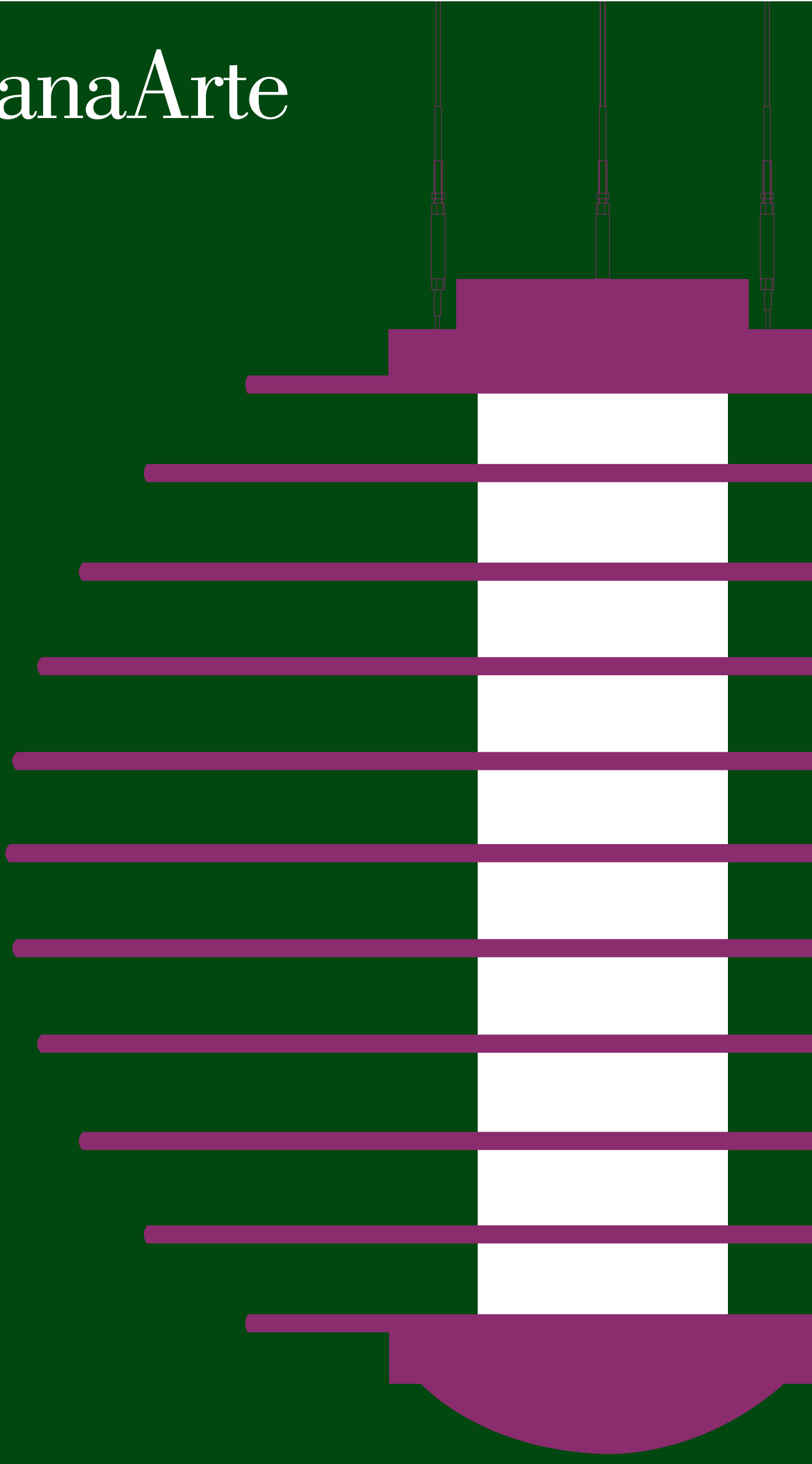

FontanaArte. The light of quality.

Statement for a social-ethical responsibility

FontanaArte. The light of quality.

The search for quality has always been our guiding light.

By "quality" we don't just mean innovative and well-made products, but also a work ethic founded on respect.

Respect for the people that work with us, in any form. Respect for the fundamental values of design and manufacturing ethics. Respect for the environment.

FontanaArte. The light of quality.

People.

Within FontanaArte, great importance is placed on the quality of interpersonal relationships. Our common goal is to ensure that the people that work with us have the best possible working environment, fully compliant with workplace health and safety legislation.

At the same time, those that work with FontanaArte are well aware that overall quality, in the form of the best design-manufacturing standards and customer satisfaction, is our main priority. Our Customers and Suppliers are our partners and we positively interact with them to reach common goals and grow together.Continuous improvement involves active research into every opportunity to identify possible inconsistencies - whichever area of the business they may arise in - understanding and eliminating their causes by adjusting the processes that caused them.

Continuous improvement also involves the definition of solid targets in line with resources, and making sure that these targets are achieved.

All our collaborators are required to operate with maximum transparency, honesty and collaborative spirit. Through collaboration and the exchange

of ideas, problems become a stimulus for improvement.

FontanaArte. The light of quality.

Design and manufacturing ethics.

FontanaArte. The light of quality.

Set up in 1932, FontanaArte is one of the Italian design companies that made "the history of light" in Italy and in the world. Founded by an architect, the company has always retained a strong link with the world of design, collaborating with some of the best Italian and international architects and lighting designers. The result of this collaboration was the creation of a true cultural approach to design, an original "point of view" on architecture, lighting and furnishings.

FontanaArte. The light of quality.

A design culture which, being based on the prevalent use of noble materials (mainly glass), found its main inspiration in the interaction between technology and beauty, generating a series of timeless and beautiful objects, some of which have become design classics and are exhibited in some of the world's most important museums. These cult objects still find favour in the market and, in their own way, contribute to environmental protection because they are so beautiful that they don't quickly become obsolete.

(And FontanaArte still makes spare parts for them!).

Research and innovation are constant features of the FontanaArte company policy, in particular with regards to the use of recyclable materials with low environmental impact: from blown glass, industrial sheet glass, aluminium, iron and high quality plastics, to packaging materials, all fully recyclable and reduced to a minimum. We also use low energy light sources both for new generation products and those that have been in the catalogue for some time. These comply with the photometric, lighting engineering and environmental requirements established by the market and international standards.

FontanaArte. The light of quality.

The environment.

FontanaArte. The light of quality.

The FontanaArte environmental policy strives to find the right balance between environmental impact and economic growth. It is an integral part of company strategy, with the viewpoint that the development of any business, in order to be sustainable, must consider the needs of the present generation without compromising the ability of future generations to satisfy theirs. The protection of environmental quality should be considered as an essential part of quality of life. In this sense, FontanaArte's commitment is also, and above all, aimed at developing sources of light and lighting engineering projects designed to combat light pollution and energy waste.

Our cities, our towns, our monuments, the public places in which we meet, work and pass through, our houses, all need a better kind of light, one

that respects the mental and physical well-being of each one of us, as well as the beauty of nature and man-made works. FontanaArte is committed

to working towards a "good" light: a light that provides better quality for all.

FontanaArte. The light of quality.

FontanaArte. The light of quality.

In summary, FontanaArte's commitment to sustainability is aimed at:

- Pursuing the continuous improvement of product quality and safety and sharing strategies for achieving the best possible level of sustainability with partners and customers.

- Investing in design culture, as a factor able to prolong product life;

- Making products from recyclable materials (glass, aluminium, iron, quality plastics), using single materials where possible.

- Investing in design and technological research, to combat light pollution.

- Progressively reducing the environmental impact of our activities through energy consumption reduction, correct waste management and material recycling.

- Packaging our products using environmentally-friendly, recyclable materials, with minimum bulk and maximum efficiency.

- Promoting the awareness of and responsibility for environmental sustainability amongst employees at all levels, using suitable informative and training programmes.

- Responsibly managing the supply chain using a network of reliable suppliers, where possible, located in our own manufacturing district.

- Being compliant with applicable environmental laws and legislation, and adopting all the necessary precautions and measures to prevent environmental problems.

FontanaArte. La luce della qualità.

Assunzione di responsabilità per uno sviluppo sostenibile etico-sociale

FontanaArte. La luce della qualità.

La ricerca della qualità è la luce che ci ha sempre guidati.

Per “qualità” non intendiamo solo prodotti innovativi e fatti a regola d'arte, ma una filosofia di lavoro che implica rispetto.

Rispetto per le persone che hanno un rapporto di lavoro con noi, in qualsiasi forma. Rispetto per i valori fondamentali dell' etica progettuale e produttiva. Rispetto per l'ambiente.

FontanaArte. La luce della qualità.

Le persone.

All'interno della FontanaArte, la qualità dei rapporti umani occupa un ruolo fondamentale, e lo sforzo comune è quello di assicurare ai collaboratori il miglior ambiente possibile nel rispetto massimo della vivibilità e delle regole sulla sicurezza del lavoro.

Nello stesso tempo, chi collabora con FontanaArte ha ben presente che la qualità generale, intesa come rispetto dei migliori standard di ricerca progettuale-produttiva e come soddisfazione delle aspettative dei nostri Clienti, è la massima priorità da raggiungere.

I Clienti e i Fornitori sono partner con i quali interagire positivamente per raggiungere obiettivi comuni e crescere insieme.

Il miglioramento continuo implica la ricerca attiva di ogni opportunità di intercettazione di possibili difetti, in qualsiasi settore dell'azienda essi si manifestino, per individuarne e rimuoverne le cause agendo sul processo che li ha generati.

Il miglioramento continuo implica anche la definizione di obiettivi concreti e commisurati alle risorse e la verifica del loro raggiungimento.

A tutti i collaboratori viene richiesto un atteggiamento improntato alla massima trasparenza, all'onestà e alla collaborazione. Attraverso la collaborazione e il confronto, i problemi diventano una spinta a migliorare.

FontanaArte. La luce della qualità.

L'etica progettuale e produttiva.

FontanaArte. La luce della qualità.

Fondata nel 1932, FontanaArte è una delle aziende italiane di design che hanno fatto la “storia della luce” in Italia e nel mondo. Nata dall’idea di un architetto, ha sempre mantenuto un forte legame con l’ambiente progettuale, coinvolgendo via via i più importanti architetti e lighting designer italiani e internazionali, che hanno costruito insieme all’azienda un vero e proprio progetto culturale, un “punto di vista” originale sull’architettura, l’illuminazione e l’arredamento.

FontanaArte. La luce della qualità.

Una cultura del progetto che, basandosi sull'utilizzo prevalente di materiali nobili (vetro in prima istanza), ha avuto nell’interazione tra tecnologia e bellezza l’idea principale, e ha generato una serie di oggetti senza tempo, dalle splendide forme, alcuni dei quali sono divenuti dei classici del design, esposti nei più importanti musei del mondo. Oggetti-culto che incontrano tuttora il favore del mercato e che, a loro modo, contribuiscono alla difesa dell’ambiente, perché sono così belli da non essere soggetti a una rapida obsolescenza.

(E FontanaArte continua a produrne i pezzi di ricambio!).

Ricerca e innovazione sono parte costante della politica aziendale. FontanaArte, in particolare per quanto riguarda l’uso dei materiali riciclabili e a basso impatto ambientale: il vetro soffiato, il vetro industriale in lastra, l’alluminio, il ferro e le plastiche di alta qualità, fino ai materiali per gli imballaggi, totalmente riutilizzabili e ridotti al minimo indispensabile. E l’impiego, sia per i prodotti di nuova generazione che per quelli già da tempo in catalogo, di fonti luminose a ridotto consumo energetico, in grado di soddisfare i requisiti fotometrici, illuminotecnici e ambientali richiesti dal mercato e dalle norme internazionali.

FontanaArte. La luce della qualità.

L'ambiente.

FontanaArte. La luce della qualità.

La politica ambientale di FontanaArte è intesa come ricerca di un giusto equilibrio tra impatto ambientale e crescita economica. Essa è parte integrante delle strategie aziendali, partendo dalla considerazione che lo sviluppo di qualsiasi azienda, per essere sostenibile, deve oggi tener conto dei bisogni delle generazioni presenti senza compromettere la capacità delle generazioni future di soddisfare i propri bisogni. La difesa della qualità dell’ambiente va considerata come una caratteristica essenziale della qualità della vita. In questo senso, l’impegno di FontanaArte è anche e soprattutto volto a produrre fonti di luce e progetti illuminotecnici che abbiano come priorità assoluta la lotta all’inquinamento luminoso e allo spreco di risorse energetiche.

Le nostre metropoli, i nostri borghi, i nostri monumenti, i luoghi pubblici dove ci ritroviamo, lavoriamo e ci spostiamo, le nostre case, hanno bisogno di una luce migliore, che rispetti il benessere psico-fisico di ciascuno di noi, ma anche la bellezza della natura e delle opere umane. FontanaArte si impegna a lavorare per una luce “buona”: una luce qualitativamente migliore per tutti.

FontanaArte. La luce della qualità.

In sintesi, l’impegno FontanaArte per la sostenibilità è volto a:

- Perseguire il miglioramento continuo della qualità e della sicurezza dei prodotti condividendo con collaboratori e clienti le strategie per raggiungere il migliore livello di sostenibilità possibile.

-Investire nella cultura del progetto, inteso come fattore in grado di determinare il prolungamento della vita del prodotto;

- Realizzare prodotti con materiali riciclabili (vetro, alluminio, ferro, plastiche di qualità) impiegando, ove possibile, mono-materiale.

- Investire nella ricerca progettuale e tecnologica, per combattere costantemente l’inquinamento luminoso.

- Ridurre in maniera progressiva l’impatto ambientale connesso con lo svolgimento di tutte le proprie attività, con attenzione continua alla riduzione dei consumi di risorse energetiche, alla corretta gestione dei rifiuti e all’ aumento del recupero dei materiali.

- Confezionare i prodotti utilizzando imballi “virtuosi” riciclabili, con il minimo dell’ingombro e il massimo dell’efficienza.

- Promuovere la sensibilità e la responsabilità dei dipendenti, impegnati ad ogni livello nelle attività aziendali, nei confronti della sostenibilità ambientale, attraverso idonei programmi di informazione e formazione.

- Gestire responsabilmente la catena degli approvvigionamenti attraverso una rete di fornitori di sicura affidabilità e il più possibile individuati all’interno del proprio distretto produttivo.

- Essere conformi alle legislazioni e regolamentazioni ambientali applicabili, e adottare tutte le precauzioni e le disposizioni necessarie alla prevenzione dei problemi ambientali.



FontanaArte











Lampade da tavolo	
Table lamps	
Lampes de table	
Tischleuchten	
Lámparas de sobremesa	
100M etri	2
2198TA	4
3247TA	6
Amélie	8
Antoo	10
Avion	12
Bilia	14
Bis - Tris	16
Chiara	18
Chignon	20
Daruma	22
Drum	24
Elvis	26
Falena	28
Fontana	30
Giova	34
Globo di Luce	36
Loop	38
Margaret	40
Naska 1, 2 - Nasketta	42
Parola	48
Passion	50
Pirellina	52
Sara	54
Thor	56
Three Sixty	58
Time 21:00	60
Uovo	62
Lampade da terra	
Floor lamps	
Lampadaires	
Stehleuchten	
Lámparas de suelo	
2198	64
3247	66
Adubai	68
Amax	70
Drum	72
Falena	74
Flora	76
Flüte - Magnum	78
Hashira	80
Lumen	82
Luminator	84
Naska 1, 2 - Nasketta	86
Nobi	92
Nuova Segno Tre	94
Parola, Parolona	96
Passion	98
Pirellone	100
Polaris	102
Prima Signora	104
Sara	106
Scintilla Terra	108
T0024	110
Three Sixty	112
Time 21:30	114
Toobo	116
Vertigo	118

























Lampade da parete	
Wall lamps	
Appliques	
Wandleuchten	
Lámparas de pared	
006	120
Ala	122
Ananas	124
Bruco	126
Calle	128
Chignon	132
Corrubedo	134
Corrubedo Fluo	134
Diamante	136
Falena	138
Flüte	140
Globo di Luce	142
Graal	144
Iceberg	146
Kiasma	148
Lounge	150
Maristella	152
Naska 1, 2 - Nasketta	154
Nobi	156
Noon	158
Parola	164
Riga	166
Sara	168
Scintilla AT1P	172
Scintilla AT1PM	174
Simple White	176
Simplicity	178
Sipario	180
Thor	182
Time 20:30	184
Toobo	186
Triple	188
Uovo	190
Velo	192
Yves	194
Lampade da parete e plafone	
Wall and ceiling lamps	
Appliques et plafonniers	
Wand- und Deckenleuchten	
Appliques y plafones	
Amélie	196
Antoo	198
Chignon	200
Factory	202
Iris	204
Lunapiena	206
Sillaba	208
Sillabone	212
Time 20:30	214









Lampade da sospensione	
Hanging lamps	
Suspensions	
Hängeleuchten	
Lámparas de techo	
006	216
0024	218
0024 XXL	220
100 Metri	222
Amax	224
Antoo	228
A Tomic	230
Aurea	232
Avico	234
Avion	238
Balthazar	240
Bolla	242
Chandelier	244
Chignon	246
Cupola	248
Duplex	250
Elvis	252
Flüte 1 - Magnum	254
Flüte 2, 3	256
Globo di Luce	258
Huna	262
Lampara	264
Luminair	266
Lunapiena	268
Morocco	270
Noaxis	272
Nobi	274
Nobona	276
Otto	280
Passion	282
Pudding	284
S1853	286
Scintilla AT1S	288
Scintilla AT1SL	290
Scintilla BT..S	292
Scintilla Sommatonia	294
Sonmi	296
Spiral Tribe	298
Tattoo	302
Time 20:30	304
Uovo	306
Velo	308
Vertigo	310

Arredo / complementi	
Furniture / Accessories	
Meubles / Objets de décoration	
Einrichtung / Gegenstände	
Muebles / Objetos	
Tavoli	
Tables	
Tables	
Tische	
Mesas	
Teso	314
Tour	316
Tavolini	
Coffe tables	
Tables basses	
Kleine Tische	
Mesitas	
Fontana	318
Tavolino 1932	320
Tavolo con ruote	322
Librerie	
Bookcases	
Bibliothèques	
Bücherregal	
Estanterías	
Teso	324
Consolle	
Console	
Consoles	
Konsole	
Consolas	
Teso	326
Appendiabiti	
Clothes stand	
Portes-manteaux	
Kleiderständer	
Colgadores	
AixoM ateix	328
Bowl	330
Vasi	
Vases	
Vases	
Vasen	
Jarrónes	
Cartoccio	332

Incandescenti / incandescent / incandescentes / Glühlampen / incandescentes (IN)
 E27
 E14
 E14

Fuorescenti / fluorescent / fluorescentes / Leuchtstofflampen / fluorescentes (FL)
 G23
 G24d-1 - G24d-2 - G24d-3 - G24q-2 - G24q-3 - GX24q-3 - GX24q-4
 2G10
 G5 - G13 - W4,3
 E14 - E27
 E27
 2G11
 2GX13 - G10q
 GX53
 E27

Alogene / halogen / halogènes / Halogenlampen / halógenas (HA)
 E14
 E14 
 E14 
 E27 
 E27 
 B15d 
 G9 
 G53 AR111
 R7s/80 
 R7s/115 
 GY6.35 - GU4 
 GU5.3 - GX5.3 
 GU10 - GZ10 
 E27 PAR20 - PAR30

Ioduri metallici / metal halide / iodures métalliques / Metalldampflampen / yoduros metálicos (MH)
 E27
 RX7s - RX7s-24
 G12
 GX8.5
 G8.5
 GX10
 PGj5
 LED

A	alluminio / aluminium / aluminium / Aluminium / aluminio
AA	alluminio antiriflesso / antireflex aluminium / aluminium antireflet / spiegelungsfreies Aluminium / aluminio antirreflejo
AG	argento / silver / argent / silberfarbig / plateado
AM	ambra / amber / ambre / Bernsteinfarbe / ámbar
AR	arancione / orange / orange / orangefarben / naranja
AXL	acciaio inossidabile / stainless steel / acier inoxydable / rostfreier Stahl / acero inoxidable
BI	bianco / white / blanc / weiß / blanco
BL	blu / blue / bleu / blau / azul
BR	bronzo / bronzed / colour bronze / bronzefarben / bronceado
BS	bianco satinato / satin white / blans satiné / weiß satiniert / blanco satinado
CR	cromo / chrome / chromé / verchromt / cromado
G	grigio / grey / gris / grau / gris
GA	grigio antiriflesso / antireflex grey / gris antireflet / spiegelungsfreies grau / gris antirreflejo
GI	giallo / yellow / jaune / gelb / amarillo
GM	grigio metallico / metallic grey / gris métallisé / metallisiert grau / gris metálico
GS	grigio scuro / dark grey / gris foncé / dunkel grau / gris oscuro
IX	acciaio inox inossidabile / natural stainless steel / acier inoxydable / rostfreier Stahl / acero inoxidable
MS	argento metallico / metallic silver / argent métallisé / silberfarbig metallisiert / plateado metallizado
N	nero / black / noir / schwarz / negro
NC	nichelato spazzolato / brushed nickel-plated / brossé nickelé / gebürstet vernickelt / niquelado cepillado
NO	nero opaco / matt black / noir opaque / matt schwarz / negro opaco
NS	nichelato satinato / satin nickel-plated / nickelé satiné / satiniert vernickelt / niquelado satinado
O	ottone / brass / laiton / Messing / latón
ON	ottone nichelato / nickel-plated brass / laiton nickelé / vernickeltes Messing / latón niquelado
OD	oro / gold / doré / vergoldet / dorado
PL	policarbonato / polycarbonate / polycarbonate / Polycarbonat / policarbonato
R	rosso / red / rouge / rot / rojo
RS	rosa / rose / rose / rosa / rosa
SA	satinato / satin / satin / satiniert / satinado
SB	vetro sabbiato / sandblasted glass / verre sablé / sandgestrahtes Glas / vidrio arenado
SP	vetro specchiato / mirror effect / verre miroir / Spiegelglass / vidrio de espejo
SR	vetro serigrafato / silk-screened glass / verre sérigraphé / siebgedrücktes Glas / vidrio serigrafado
TR	trasparente / transparent / transparent / transparent / transparente
V	verde / green / vert / grün / verde
VBI	vetro bianco / white glass / verre blanc / weißes Glas / vidrio blanco
VF	verde foresta / forest green / vert forêt / Waldgrün / verde selva
VI	ametista / amethyst / améthyste / Amethyst / amatista
VS	vetro satinato / satin glass / verre satiné / satiniertes Glas / vidrio satinado

Simboli / Symbols / Symboles / Symbole / Símbolos

	Lampade da tavolo / Table lamps / Lampes de tables / Tischleuchten / Lámparas de sobremesa
	Lampade da terra / Floor lamps / Lampadaires / Stehleuchten / Lámparas de suelo
	Lampade da parete / Wall lamps / Appliques / Wandleuchten / Lámparas de pared
	Lampade da semincasso / Semi-recessed lamps / Lampes à semi encastrer / Halbeinbauleuchten / Lámparas semi empotrables
	Plafoniere / Ceiling lamps / Plafonniers / Deckenleuchten / Plafones
	Sospensione/ Hanging lamps / Suspensions / Hängeleuchten / Lámparas de techo
	Istituto italiano Marchio di Qualità / Italian Institut of Quality Mark / Institut Italien de la Marque de Qualité / Italienisches Institut für Qualitätsmarktsicherung / Instituto Italiano de la Marca de Calidad
	Marchio Comunità Europea / European Community Mark / Certificat de Conformité Européenne / Zertification Europäische Gemeinschaft / Certificado Comunidad Europea
	Apparecchi idonei al montaggio diretto su superfici normalmente incombustibili / Suitable for installation on inflammable surfaces / Appareil utilisable sur les surfaces inflammables / Gerät zum unmittelbaren Einbau in normal entflammbaren Flächen geeignet / Aparato indicado para el montaje directo sobre superficies inflamables
	Marchio americano di certificazione / Underwriters Laboratories Inc. / Marque de certification américaine / Zertification nach der amerikanischen Norm / Certificado de conformidad americano
	Certificazione di Conformità Europea / Certification of European Conformity / Certificat de conformité à la norme Européenne / Zertification nach der europäischen Norm / Certificado de Conformidad Europeo
	Marchio di Certificazione Cinese / China Compulsory Certification / Marque de certification chinoise / Zertification nach der chinesischen Norm / Certificado de conformidad chino
	Marchio di Certificazione Danese / Danish certification mark / Marque de certification danoise / Zertifikation nach der dänischen Norm / Certificado de conformidad danés
IP	Grado di protezione / Degree of protection / Indice de protection / Schutzart / Grado de protección
	Classe II / Class II / Classe II / Schutzklasse II / Clase II
	Classe III / Class III / Classe III / Schutzklasse III / Clase III
	Distanza minima dagli oggetti illuminati / Shortest distance of the lamp to the illuminated object / Distance la plus coultre entre la lampe et l'objet illumine / Kurzester Abstand der Lampe zum feuergefährlichen Material / Distancia minima entre la lámpara y los objetos iluminados
	Resistenza a urti fino a 5 kg. / Shock resistant up to 5 kg / résistant aux chocs jusqu'à 5 Kg / Bis 5 Kilo Stoßfest / resistente a impactos hasta 5 Kg
	New Halogen Energy Saver

Nome / name	Prodotto / product	Anno / year	Tipologia / typology	Nome / name	Prodotto / product	Anno / year	Tipologia / typology
A							
Marco Acerbis	Avion	2009	lampada da tavolo / table lamp	Pietro Chiesa	Cartoccio	1932	oggetti - vaso / objects - vase
Marco Acerbis	Avion	2009	lampada a sospensione / suspension lamp	Pietro Chiesa	Fontana	1932	arredo - tavolino / furniture - coffee table
Marco Acerbis	Iris	2007	plafoniera / ceiling lamp	Pietro Chiesa	Luminator	1933	lampada da terra / floor lamp
Marco Acerbis	Polaris	2007	lampada da terra / floor lamp	David Chipperfield	Chandelier	2004	lampada a sospensione / suspension lamp
Marco Acerbis	Vertigo	2005	lampada da terra / floor lamp	David Chipperfield	Corrubedo	2005	lampada da parete / wall lamp
Marco Acerbis	Vertigo	2005	lampada a sospensione / suspension lamp				
Archivio Storico	006	1933	lampada da parete / wall lamp	F			
Archivio Storico	006/5	1933	lampada a sospensione / suspension lamp	Foster + Partners	Three Sixty	2005	lampada da tavolo / table lamp
Archivio Storico	006/20	1994	lampada a sospensione / suspension lamp	Foster + Partners	Three Sixty	2008	lampada da terra / floor lamp
Archivio Storico	2198	1954	lampada da terra / floor lamp	Future Systems	Flora	2007	lampada da terra / floor lamp
Archivio Storico	2198TA	1954	lampada da tavolo / table lamp				
Archivio Storico	3247TA	1965	lampada da tavolo / table lamp	G			
Archivio Storico	3247	1954	lampada da terra / floor lamp	Riccardo Giovanetti	Sipario	2007	lampada da parete / wall lamp
Archivio Storico	Bis / Tris	1941	lampada da tavolo / table lamp				
Archivio Storico	Cupola	1933	lampada a sospensione / suspension lamp	H			
Archivio Storico	Huna	1965	lampada a sospensione / suspension lamp	Harry & Camila	Amélie	2003	lampada da tavolo / table lamp
Archivio Storico	Lampara	1954	lampada a sospensione / suspension lamp	Harry & Camila	Amélie	2004	lampada da parete-plafone/wall-ceiling lamp
Archivio Storico	Lumen	1954	lampada da terra / floor lamp	Harry & Camila	Bolla	2003	lampada a sospensione / suspension lamp
Archivio Storico	Maristella	1995	lampada da parete / wall lamp	Steven Holl	Kiasma	2000	lampada da parete / wall lamp
Archivio Storico	Naska 1	1933	lampada da tavolo / table lamp	Steven Holl	Triple	2000	lampada da parete / wall lamp
Archivio Storico	Naska 2	1933	lampada da tavolo / table lamp				
Archivio Storico	Nasketta	1933	lampada da tavolo / table lamp	I			
Archivio Storico	Naska 1	1933	lampada da terra / floor lamp	Max Ingrand	Fontana	1954	lampada da tavolo / table lamp
Archivio Storico	Naska 2	1933	lampada da terra / floor lamp				
Archivio Storico	Nasketta	1933	lampada da terra / floor lamp	M			
Archivio Storico	Naska 1	1933	lampada da parete / wall lamp	Vico Magistretti	Ananas	1999	lampada da parete / wall lamp
Archivio Storico	Naska 2	1933	lampada da parete / wall lamp	Vico Magistretti	Bruco	2003	lampada da parete / wall lamp
Archivio Storico	Nasketta	1933	lampada da parete / wall lamp	Vico Magistretti	Margaret	2000	lampada da tavolo / table lamp
Archivio Storico	Otto	1979	lampada a sospensione / suspension lamp	Vico Magistretti	Morocco	1998	lampada a sospensione / suspension lamp
Archivio Storico	Pudding	1995	lampada a sospensione / suspension lamp	Roberto Menghi	Globo di Luce	1968	lampada da tavolo / table lamp
Archivio Storico	S1853	1954	lampada a sospensione / suspension lamp	Roberto Menghi	Globo di Luce	1968	lampada da parete / wall lamp
Archivio Storico	Simple White	1994	lampada da parete / wall lamp	Roberto Menghi	Globo di Luce	1968	lampada a sospensione / suspension lamp
Archivio Storico	Uovo	1972	lampada da tavolo / table lamp	Marco Merendi	Tattoo	2009	lampada a sospensione / suspension lamp
Archivio Storico	Uovo	2004	lampada da parete / wall lamp	Marco Merendi	Toobo	2007	lampada da terra / floor lamp
Archivio Storico	Uovo	1972	lampada a sospensione / suspension lamp	Marco Merendi	Toobo	2007	lampada da parete / wall lamp
Gianni Arnaudo	Graal	2008	lampada da parete / wall lamp	Metis	Hashira	1993	lampada da terra / floor lamp
Sergio Asti	Daruma	1968	lampada da tavolo / table lamp	Metis	Nobi	1992	lampada da tavolo / table lamp
Gae Aulenti	Giova	1964	lampada da tavolo / table lamp	Metis	Nobi	1992	lampada da terra / floor lamp
Gae Aulenti	Tavolino	1982	arredo - tavolino / furniture - coffee table	Metis	Nobi	1992	lampada da terra / floor lamp
Gae Aulenti	Tavolo con Ruote	1980	arredo - tavolino / furniture - coffee table	Metis	Nobi	1992	lampada da terra / floor lamp
Gae Aulenti	Tour	1993	arredo - tavolo / furniture -table	Metis	Nobi	1992	lampada da parete / wall lamp
Gae Aulenti / Piero Castiglioni	Calle	1988	lampada da parete / wall lamp	Metis	Nobi	1992	lampada da parete / wall lamp
Gae Aulenti / Piero Castiglioni	Diamante	1986	lampada da parete / wall lamp	Metis	Nobi	1992	lampada a sospensione / suspension lamp
Gae Aulenti / Piero Castiglioni	Parola	1980	lampada da tavolo / table lamp	Metis	Nobi	1992	lampada a sospensione / suspension lamp
Gae Aulenti / Piero Castiglioni	Parola, Parolona	1980	lampada da terra / floor lamp	Metis	Nobi	1992	lampada a sospensione / suspension lamp
Gae Aulenti / Piero Castiglioni	Parola	1981	lampada da parete / wall lamp	Metis	Nobona	1998	lampada a sospensione / suspension lamp
B							
Studio Beretta	Passion	2004	lampada da tavolo / table lamp	P			
Studio Beretta	Passion	2004	lampada da terra / floor lamp	Luciano Pagani / Angelo Perversi	Thor	2000	lampada da tavolo / table lamp
Studio Beretta	Passion	2005	lampada a sospensione / suspension lamp	Luciano Pagani / Angelo Perversi	Thor	2000	lampada da parete / wall lamp
Valérie Bergeron	Aixo Mateix	1994	arredo-appendiabiti/furniture-clothes stand	Studio Parisotto / Formenton	Time 20:30	2008	lampada da parete / wall lamp
C				Studio Parisotto / Formenton	Time 20:30	2008	lampada da semincasso / semi-recessed lamp
Luisa Calvi / Mauro Merlini / Carlos Moya	Lounge	2003	lampada da parete / wall lamp	Studio Parisotto / Formenton	Time 20:30	2006	lampada a sospensione / suspension lamp
Piero Castiglioni	Sillaba	1972	lampada da parete-plafone/wall-ceiling lamp	Studio Parisotto / Formenton	Time 21:00	2006	lampada da tavolo / table lamp
Piero Castiglioni	Sillabone	1988	lampada da parete-plafone/wall-ceiling lamp	Studio Parisotto / Formenton	Time 21:30	2003	lampada da terra / floor lamp
Livio / Piero Castiglioni	Scintilla AT1P	1988	lampada da parete / wall lamp	Park Associati (Filippo Pagliani / Michele Rossi)	Iceberg	2006	lampada da parete / wall lamp
Livio / Piero Castiglioni	Scintilla AT1S	1972	lampada a sospensione / suspension lamp	Julian Pastorino / Cecilia Suarez	Antoo	2009	lampada da tavolo / table lamp
Livio / Piero Castiglioni	Scintilla AT1SL	1972	lampada a sospensione / suspension lamp	Julian Pastorino / Cecilia Suarez	Antoo	2009	plafoniera / ceiling lamp
Livio / Piero Castiglioni	Scintilla BT1P	1988	lampada da parete / wall lamp	Julian Pastorino / Cecilia Suarez	Antoo	2009	lampada a sospensione / suspension lamp
Livio / Piero Castiglioni	Scintilla BT1S	1972	lampada a sospensione / suspension lamp	Alessandro Pedretti (Studio Rota & Partners)	Noaxis	2007	lampada a sospensione / suspension lamp
Livio / Piero Castiglioni	Scintilla Sommatoria	1972	lampada a sospensione / suspension lamp	Alessandro Pedretti (Studio Rota & Partners)	Noon	2007	lampada da parete / wall lamp
Livio / Piero Castiglioni	Scintilla Terra	1983	lampada da terra / floor lamp	Gabi Peretto	Simplicity	2010	lampada da parete / wall lamp
Caturegli / Formica / Metis	Sonmi	2006	lampada a sospensione / suspension lamp	Gabi Peretto	Spiral Tribe	2009	lampada a sospensione / suspension lamp
Pierluigi Cerri (Gregotti Associati)	Nuova Segno Tre	1993	lampada da terra / floor lamp	Renzo Piano	Yves	2009	lampada da parete / wall lamp
Pierluigi Cerri (Gregotti Associati)	Sara	1993	lampada da tavolo / table lamp	Renzo Piano	Teso	1991	arredo - consolle / furniture - console
Pierluigi Cerri (Gregotti Associati)	Sara	1988	lampada da terra / floor lamp	Renzo Piano	Teso	1989	arredo - libreria / furniture - bookcase
Pierluigi Cerri (Gregotti Associati)	Sara	1933	lampada da parete / wall lamp	Renzo Piano	Teso	1985	arredo - tavolo / furniture -table
Pietro Chiesa	Cartoccio	1932	oggetti - vaso / objects - vase	Gio Ponti	0024	1931	lampada a sospensione / suspension lamp
				Gio Ponti	0024XXL	1931	lampada a sospensione / suspension lamp
				Gio Ponti	Bilia	1931	lampada da tavolo / table lamp

Architectural - indice per Designer / Designer's index

Nome / name	Prodotto / product	Anno / year	Tipologia / typology	Nome / name	Prodotto / product	Anno / year	Tipologia / typology
Gio Ponti	Pirellina	1967	lampada da tavolo / table lamp	A			
Gio Ponti	Pirellone	1967	lampada da terra / floor lamp	Giovanni Albera/Nicolas Monti	Mercurio	2005	Interno / indoor
Gio Ponti	T0024	1932	lampada da terra / floor lamp	Gae Aulenti	Alcamo	2002	Esterno / outdoor
Gio Ponti	Tavolino 1932	1932	arredo - tavolino / furniture - coffee table	Gae Aulenti / Piero Castiglioni	Diastema	1994	Interno / indoor
Daniela Puppa	Balthazar	2010	lampada a sospensione / suspension lamp	B			
Daniela Puppa	Prima Signora	1992	lampada da terra / floor lam	Dante Bonuccelli	Linea 1	2009	Interno / indoor
R				Dante Bonuccelli	Linea 2	2009	Interno / indoor
Franco Raggi	Drum	2005	lampada da tavolo / table lamp	Dante Bonuccelli	Stecca	2007	Interno / indoor
Franco Raggi	Drum	2005	lampada da terra / floor lamp	C			
Franco Raggi	Flûte	1999	lampada da parete / wall lamp	Calvi/Merlini/Moya	Spotty	2003	Interno / indoor
Franco Raggi	Flûte - Magnum	1999	lampada da terra / floor lamp	Piero Castiglioni	5136	1993	Interno / indoor
Franco Raggi	Flûte - Magnum	1999	lampada a sospensione / suspension lamp	Piero Castiglioni	Acca	1992	Esterno / outdoor
Franco Raggi	Flûte 2	1999	lampada a sospensione / suspension lamp	Piero Castiglioni	Circo	1996	Interno / indoor
Franco Raggi	Flûte 3	1999	lampada a sospensione / suspension lamp	Piero Castiglioni	Pays d'Aix	2007	Interno / indoor
Franco Raggi	Velo	1988	lampada da parete / wall lamp	Piero Castiglioni	Scintilla	1972	Interno / indoor
Franco Raggi	Velo	1989	lampada a sospensione / suspension lamp	Livio/Piero Castiglioni	Corrubedo	2008	Esterno / outdoor
Roberto Righetti	Lunapiena	2003	lampada da parete-plafone/wall-ceiling lamp	David Chipperfield	Slot	2005	Interno / indoor
Roberto Righetti	Lunapiena	2003	lampada a sospensione / suspension lamp	F			
Piero Russi	Chignon	2010	lampada da tavolo / table lamp	Ferrara Palladino e Associati	Bobush	2010	Esterno / outdoor
Piero Russi	Chignon	2009	lampada da parete-plafone/wall-ceiling lamp	Ferrara Palladino e Associati	Botree	2009	Esterno / outdoor
Piero Russi	Chignon	2010	lampada a sospensione / suspension lamp	Future Systems	Flora	2008	Esterno / outdoor
S				L			
Denis Santachiara	Aurea	2005	lampada a sospensione / suspension lamp	Francesca Lavizzari/Gianni Ravelli	Step	1995	Esterno / outdoor
Denis Santachiara	Luminair	2005	lampada a sospensione / suspension lamp	M			
Alvaro Siza	Falena	1994	lampada da tavolo / table lamp	Angelo Mangiarotti	Plastica	2005	Esterno / outdoor
Alvaro Siza	Falena	1994	lampada da terra / floor lamp	Marco Mascetti/MrSmith Studio	Medito	2006	Interno - esterno / Indoor - outdoor
Alvaro Siza	Falena	1994	lampada da parete / wall lamp	Metis	Arianna	2000	Interno / indoor
T				Metis	Led Me Go	2006	Interno / indoor
Carlo Tamborini	Duplex	2000	lampada a sospensione / suspension lamp	Metis	Nobi	1997	Interno / indoor
U				Metis	Teleflù	2001	Interno / indoor
Ufficio Tecnico	Chiara	2003	lampada da tavolo / table lamp	Marco Merendi	Chips	2008	Esterno / outdoor
Paolo Ulian	Bowl	2003	arredo-appendiabiti/furniture-clothes stand	Marco Merendi	Toobo	2007	Esterno / outdoor
W				Metis	Gallery	2006	Interno / indoor
Charles Williams	Amax	2008	lampada da terra / floor lam	Metis	Garden Soft	2006	Esterno / outdoor
Charles Williams	Amax	2003	lampada a sospensione / suspension lamp	Metis	Kodo	1998	Interno - esterno / Indoor - outdoor
Charles Williams	Avico	2006	lampada a sospensione / suspension lamp	Metis	Koi	1992	Interno / indoor
Charles Williams	Elvis	1999	lampada da tavolo / table lamp	Metis	Raso IP20	2003	Interno / indoor
Charles Williams	Elvis	1998	lampada a sospensione / suspension lamp	Metis	Raso IP67	2003	Esterno / outdoor
Voon Wong / Benson Saw	Loop	2003	lampada da tavolo / table lamp	Metis	Raso Q	2003	Esterno / outdoor
Z				P			
Paolo Zani	A Tomic	2003	lampada a sospensione / suspension lamp	Dominique Perrault/G�elle Lauriot-Pr�evost	V-Light/V-Mast	2004	Esterno / outdoor
Paolo Zani	Riga	1995	lampada da parete / wall lamp	Q			
Marco Zanuso Jr.	Factory	2009	lampada da parete-plafone/wall-ceiling lamp	Maurizio Quargnale	Invisibile	2008	Interno / indoor
Alberto Zecchini	100 Metri	2007	lampada da tavolo / table lamp	Maurizio Quargnale	Cordolo	2009	Esterno / outdoor
Alberto Zecchini	100 Metri	2007	lampada a sospensione / suspension lamp	S			
				Laurinda Spear (Arquitectonica Studio)	Cuboid	2009	Interno / indoor
				Laurinda Spear (Arquitectonica Studio)	Big Cuboid	2010	Interno / indoor
				T			
				Ufficio Tecnico	Cavi Paralleli		Interno / indoor
				Ufficio Tecnico	Lucciola	2007	Interno / indoor
				Ufficio Tecnico	Uovo	2008	Esterno / outdoor
				Ufficio Tecnico	Walled	2010	Interno - esterno / Indoor - outdoor
				Matteo Thun	Kombù	2002	Interno / indoor
				W			
				Charles Williams	Amax	2008	Esterno / outdoor
				Charles Williams	Avico	2008	Esterno / outdoor
				Z			
				Marco Zanuso Jr.	Flame Box	2005	Esterno / outdoor
				Paolo Zani	Riga	2008	Esterno / outdoor



Marco Acerbis



Livio Castiglioni



Riccardo Giovannetti



Metis



Renzo Piano



Laurinda Spear
(Arquitectonica
Studio)



Giovanni Albera
Nicolas Monti



Piero Castiglioni



Harry & Camila



Matteo Nunziati

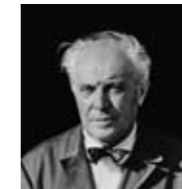

Gio Ponti



Filippo Taidelli



Gianni Arnaudo



Caturegli
Formica



Steven Holl



Julian Pastorino
Cecilia Suarez



Daniela Puppa



Carlo Tamborini



Sergio Asti



Pierluigi Cerri
(Gregotti Associati)



Max Ingrand



Luciano Pagani
Angelo Perversi



Maurizio Quargnale



Matteo Thun



Gae Aulenti



Pietro Chiesa



Vico Magistretti



Studio
Parisotto/Formenton



Franco Raggi



Paolo Ulian



Studio Beretta



David Chipperfield



Angelo Mangiarotti



Park Associati
(Filippo Pagani
Michele Rossi)



Roberto Righetti



Voon Wong
Benson Saw



Valérie Bergeron



Ferrara Palladino
e Associati



Marco Mascetti
(MrSmith Studio)



Alessandro Pedretti
(Studio Rota &
Partners)



Piero Russi



Paolo Zani



Dante Bonuccelli



Foster + Partners



Roberto Menghi



Gabi Peretto



Denis Santachiara



Alberto Zecchini



Luisa Calvi
Mauro Merlini
Carlos Moya



Future System



Marco Merendi



Dominique Perrault /
G elle Lauriot Pr evost



Alvaro Siza



Marco Zanuso Jr.

Lampade da tavolo
Table lamps
Lampes de table
Tischleuchten
Lámparas de sobremesa



2
100 Metri
Alberto Zecchini



4
2198TA
Archivio Storico



6
3247 TA
Archivio Storico



8
Amélie
Harry & Camila



10
Antoo
Julian Pastorino /
Cecilia Suarez



12
Avion
Marco Acerbis



14
Bilia
Gio Ponti



16
Bis, Tris
Archivio Storico



18
Chiara
Ufficio Tecnico



20
Chignon
Piero Russi



22
Daruma
Sergio Asti



24
Drum
Franco Raggi



26
Elvis
Charles Williams



28
Falena
Alvaro Siza



30
Fontana
Max Ingrand



34
Giova
Gae Aulenti



36
Globo di Luce
Roberto Menghi



38
Loop
Voon Wong /
Benson Saw



40
Margaret
Vico Magistretti



42
Naska 1, 2 - Nasketta



48
Parola
Gae Aulenti /
Piero Castiglioni



50
Passion
Studio Beretta



52
Pirellina
Gio Ponti



54
Sara
Pierluigi Cerri
(Gregotti Associati)



56
Thor
Luciano Pagani /
Angelo Perversi



58
Three Sixty
Foster + Partners



60
Time 21:00
Studio Parisotto /
Formenton



62
Uovo
Archivio Storico

Lampade da terra
Floor lamps
Lampadaires
Stehleuchten
Lámparas de suelo



64
2198
Archivio Storico



66
3247
Archivio Storico



68
Adubai
Matteo Nunziati



70
Amax
Charles Williams



72
Drum
Franco Raggi



74
Falena
Alvaro Siza



76
Flora
Future System



78
Flûte - Magnum
Franco Raggi



80
Hashira
Metis



82
Lumen
Archivio Storico



84
Luminator
Pietro Chiesa



86
Naska 1, 2 - Nasketta



92
Nobi
Metis



88
Nobi
Metis



90
Nobi
Metis



94
Nuova Segno Tre
Pierluigi Cerri
(Gregotti Associati)



96
Parola, Parolona
Gae Aulenti /
Piero Castiglioni



98
Passion
Studio Beretta



100
Pirellone
Gio Ponti



102
Polaris
Marco Acerbis



104
Prima Signora
Daniela Puppa



106
Sara
Pierluigi Cerri
(Gregotti Associati)



108
Scintilla Terra
Piero Castiglioni



110
T0024
Gio Ponti

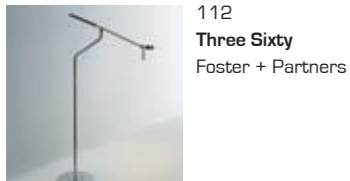

112
Three Sixty
Foster + Partners



128
Calle
Gae Aulenti /
Piero Castiglioni



148
Kiasma
Steven Holl

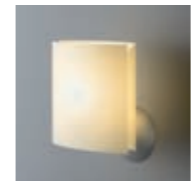

170
Sara
Pierluigi Cerri
(Gregotti Associati)



188
Triple
Steven Holl

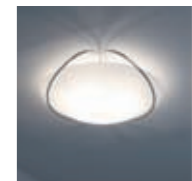

204
Iris
Marco Acerbis



114
Time 21:30
Studio Parisotto /
Formenton



130-132
Chignon
Piero Russi



150
Lounge
Luisa Calvi /
Mauro Merlini /
Carlos Moya



172
Scintilla AT1P
Livio / Piero Castiglioni



190
Uovo
Archivio Storico

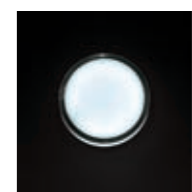

206
Lunapiena
Roberto Righetti



116
Toobo
Marco Merendi



134
**Corrubedo -
Corrubedo Fluo**
David Chipperfield



152
Maristella
Archivio storico



174
Scintilla BT1P
Livio / Piero Castiglioni



192
Velo
Franco Raggi

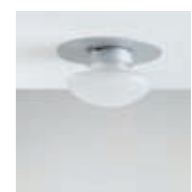

208
Sillaba
Piero Castiglioni



118
Vertigo
Marco Acerbis



136
Diamante
Gae Aulenti /
Piero Castiglioni



154
Naska 1, 2 - Nasketta



176
Simple White
Archivio Storico



194
Yves
Gabi Peretto



212
Sillabone
Piero Castiglioni

Lampade da parete
Wall lamps
Appliques
Wandleuchten
Lámparas de pared



138
Falena
Alvaro Siza

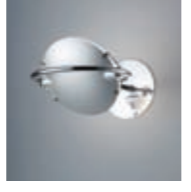

156
Nobis
Metis



178
Simplicity
Gabi Peretto 2010

Lampade da parete e plafone
Wall and ceiling lamps
Appliques et plafonniers
Wand- und Deckenleuchten
Appliques y plafones



214
Time 20:30
Studio Parisotto /
Formenton



120
006
Archivio Storico



140
Flûte
Franco Raggi



160
Nobis
Metis



180
Sipario
Riccardo Giovannetti



196
Amélie
Harry & Camila

Lampade da sospensione
Hanging lamps
Suspensions
Hängeleuchten
Lámparas de techo



122
Ala
Filippo Taidelli

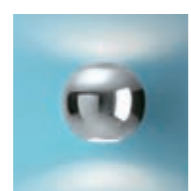

142
Globo di Luce
Roberto Menghi



162
Noon
Alessandro Pedretti
(Studio Rota &
Partners)

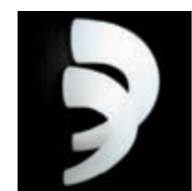

182
Thor
Luciano Pagani /
Angelo Perversi



198
Antoo
Julian Pastorino /
Cecilia Suarez



216
006/5 - 006/20
Archivio Storico



124
Ananas
Vico Magistretti



144
Graal
Gianni Arnaudo



164
Parola
Gae Aulenti /
Piero Castiglioni

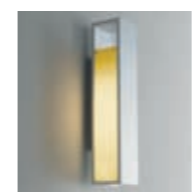

184
Time 20:30
Studio Parisotto /
Formenton

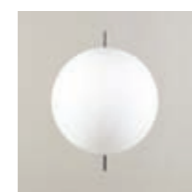

200
Chignon
Piero Russi

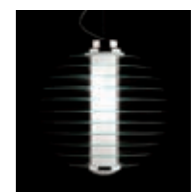

218
0024
Gio Ponti

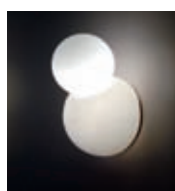

126
Bruco
Vico Magistretti



146
Iceberg
Park Associati
(Filippo Pagani /
Michele Rossi)



166
Riga
Paolo Zani



186
Toobo
Marco Merendi

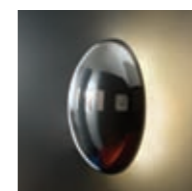

202
Factory
Marco Zanuso Jr.

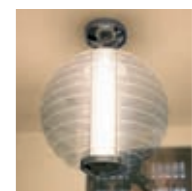

220
0024XXL
Gio Ponti

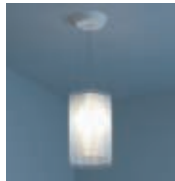

222
100 Metri
Alberto Zecchini



244
Chandelier
David Chipperfield



264
Lampara
Archivio Storico



282
Passion
Studio Beretta



302
Tattoo
Marco Merendi



320
Tavolino 1932
Gio Ponti



224
Amax
Charles Williams



246
Chignon
Piero Russi



266
Luminair
Denis Santachiara



284
Pudding
Archivio Storico



304
Time 20:30
Studio Parisotto / Formanton



322
Tavolo con Ruote
Gae Aulenti



228
Antoo
Julian Pastorino / Cecilia Suarez



248
Cupola
Archivio Storico



268
Lunapiena
Roberto Righetti



286
S1853
Archivio Storico



306
Uovo
Archivio Storico



324
Teso
Renzo Piano



230
A Tomic
Paolo Zani

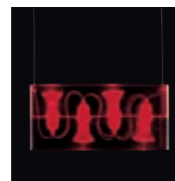

250
Duplex
Carlo Tamborini



270
Morocco
Vico Magistretti



288
Scintilla AT1S
Livio / Piero Castiglioni



308
Velo
Franco Raggi



326
Teso
Renzo Piano



232
Aurea
Denis Santachiara



252
Elvis
Charles Williams



272
Noaxis
Alessandro Pedretti
(Studio Rota & Partners)



290
Scintilla AT1SL
Livio / Piero Castiglioni



310
Vertigo
Marco Acerbis



328
Aixo Mateix
Valérie Bergeron



234
Avico
Charles Williams



254
Flûte 1 - Magnum
Franco Raggi



274
Nobi
Metis



292
Scintilla BT1S
Livio / Piero Castiglioni

Arredo / complementi
Furniture / Accessories
Meubles / Objets de décoration
Einrichtung / Gegenstände
Muebles / Objetos



330
Bowl
Paolo Ulian



238
Avion
Marco Acerbis



256
Flûte 2, 3
Franco Raggi



276
Nobi
Metis



294
Scintilla Sommatória
Livio / Piero Castiglioni



314
Teso
Renzo Piano

Vasi
Vases
Vases
Vasen
Jarrónes



240
Balthazar
Daniela Puppa



258
Globo di Luce
Roberto Menghi



278
Nobona
Metis



296
Sonmi
Caturegli / Formica / Metis



316
Tour
Gae Aulenti



332
Cartoccio
Pietro Chiesa



242
Bolla
Harry & Camila



262
Huna
Archivio Storico



280
Otto
Archivio Storico



300
Spiral Tribe
Gabi Peretto



318
Fontana
Pietro Chiesa



336
Cartoccio
Pietro Chiesa



Lighting

- Lampade nate dallo stretto e fecondo rapporto fra creatività colta e originale e capacità produttiva aperta all'innovazione. Un percorso mai interrotto tra l'azienda e gli architetti che si rinnova costantemente nel tempo dando vita a proposte e soluzioni nel segno dell'eleganza, della qualità e dell'efficienza della luce e della sostenibilità.
- Lighting fixtures which bring to mind vivid impressions of a close relationship between creativity and a productive capacity open to innovation. Because this company has always had a strong relationship with architects this has provided the ability to bring to life proposals and solutions as a mark of elegance, quality, lighting performances and sustainability.
- Lampes nées d'un étroit et fécond rapport entre créativité avertie et originale, et capacité productive ouverte à l'innovation. Un parcours ininterrompu entre l'entreprise et les architectes qui se renouvelle constamment au cours du temps, en donnant vie à propositions et solutions sous le signe de l'élégance, de la qualité et de l'efficiencia de la lumière éco-soutenable.
- Leuchten, die aus der engen Beziehung zwischen Kreativität und origineller, innovativer Produktionskraft geboren sind. Dies ist ein fortführender Weg zwischen der Firma und den Architekten, der sich im Laufe der Zeit dauernd erneuert, und somit Vorschlägen, Lösungen im Sinne der Eleganz, der Qualität und der Leistungsfähigkeit des Lichtes und der Vertretbarkeit leben gibt.
- Lámparas que nacen de los estrechos y fecundos lazos entre la creatividad original y la capacidad productiva abierta a la innovación. Un hilo continuo entre la empresa y los diseñadores, que se renueva y se refuerza con el paso del tiempo dando vida a propuestas y soluciones como señal de elegancia, de la calidad, de la eficiencia de la luz y de la sostenibilidad.

100 Metri

Alberto Zecchini 2007



Jesse, Francenigo (TV)



Lampada da tavolo.
Diffusore in vetro trasparente avvolto da un cavo in Rilsan trasparente. Cavo, interruttore e spina trasparenti.

Table lamp. Diffuser in transparent glass wound by a cable in transparent Rilsan. Transparent electrical cord, switch and plug.

Lampe de table. Diffuseur en verre transparent enveloppé d'un câble en Rilsan transparent. Câble, interrupteur et prise transparents.

Tischlampe. Schirm aus transparentem Glas, das durch ein transparentes Kabel in Rilsan aufgewickelt wird. Netzkabel, Schalter und Netzstecker transparent.

Lámpara de sobremesa. Difusor de cristal transparente arrollado por un cable de Rilsan transparente. Cable eléctrico, interruptor y enchufe transparente.

3856	∅ 15 x 60		1x20W (FL) E27
3856/1	∅ 25 x 45		3x15W (FL) E27
3856/2	∅ 25 x 45		1x20W (FL) E27

   IP20

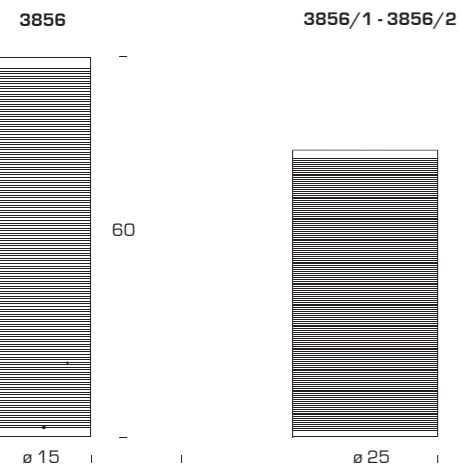

Minotti, Salone del Mobile, Milano

2198TA

Archivio Storico 1954



Lampada da tavolo con dimmer. Diffusore in vetro soffiato bianco satinato. Stelo in legno di pero. Base in metallo verniciato color alluminio. A richiesta diffusore in polietilene per ordini speciali.

Table lamp with dimmer. Diffuser in satin white blown glass. Stem in pear wood. Base in metal. Upon request diffuser in polyethylene for special orders.

Lampe de table avec dimmer. Diffuseur en verre soufflé blanc satiné. Tige en bois de poirier. Base en métal couleur aluminium. Sur demande diffuseur en polyéthylène pour commandes spéciales.

Tischlampe mit Dimmer. Schirm aus weißem geblasenem satiniertem Glas. Stiel aus Birnbauholz. Sockel aus Metall, Aluminiumfarbe lackiert. Auf Nachfrage Schirm aus Polyäthylén für Sonderbestellungen.

Lámpara de sobremesa con dimmer. Difusor de cristal soplado blanco satinado. Tija de madera de peral. Pie de metal pintado color aluminio. A petición difusor de polietileno para pedidos especiales.

2198TA/0	∅ 20 x 46		1x75W (IN) o/or 1x70W (HA) (ES) o/or 1x16W (FL) E27
2198TA	∅ 32 x 60		1x100W (HA) (ES) o/or 1x20W (FL) E27

2198TA special version

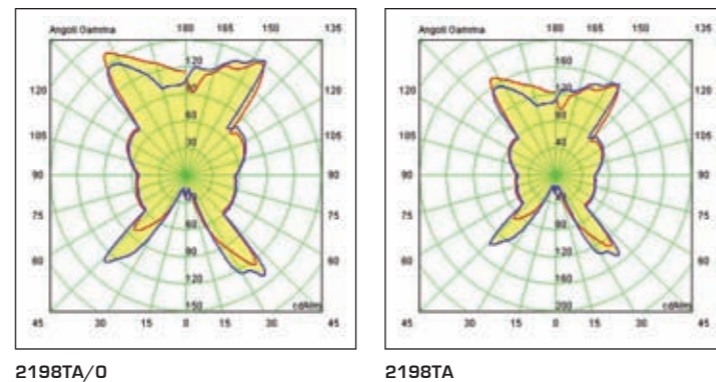
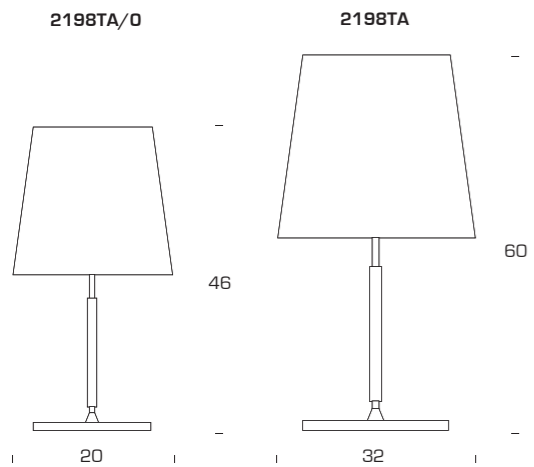

Bonaldo, Villanova (PD)

3247TA

Archivio Storico 1954



Lampada da tavolo con dimmer. Diffusore in vetro incamiciato multistrato, interno bianco, bianco oppure rosso satinato. Montatura in metallo nichelato. A richiesta diffusore in polietilene per ordini speciali.

Table lamp with dimmer. Diffuser made of glass "incamiciato", multilayers, internally white, externally white or red satin. Nickel-plated metal frame. Upon request diffuser in polyethylene for special orders.

Lampe de table avec dimmer. Diffuseur en verre gainé multicouches, blanc intérieur, blanc ou rouge opalin satiné extérieur. Monture en métal nickelé. Sur demande diffuseur en polyéthylène pour commandes spéciales.

Tischlampe mit Dimmer. Schirm aus mehrschichtigem Glas, innen weiß, außen weiß oder rot. Gestell aus vernickeltem Metall. Auf Nachfrage Schirm aus Polyäthylene für Sonderbestellungen.

Lámpara de sobremesa con dimmer. Difusor de cristal encamizado multistrato, interior blanco, blanco o rojo satinado exterior. Estructura de metal niquelado. A petición difusor de polietileno para pedidos especiales.



3247TA/0 - 3247TA/0/R	∅ 20 x 46		1x75W (IN) o/or 1x70W (HA) o/or 1x16W (FL) E27
3247TA - 3247TA/R	∅ 32 x 60		1x100W (HA) o/or 1x20W (FL) E27

IP20 3247TA - 3247TA/R special version

3247TA/0 - 3247TA/0/R

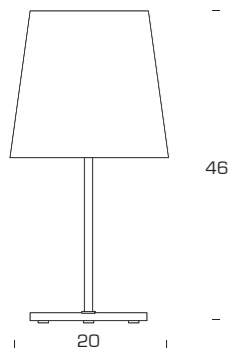

3247TA - 3247TA/R

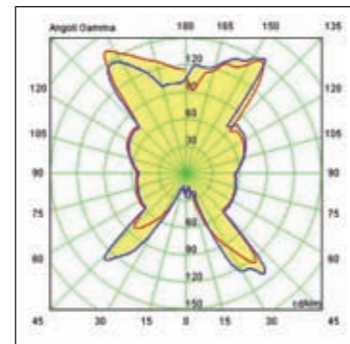
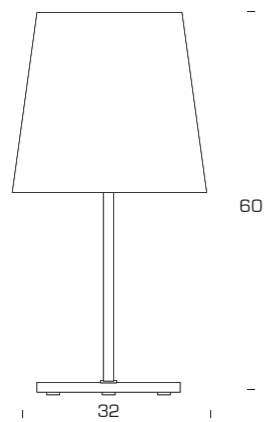

3247TA/0 - 3247TA/0/R

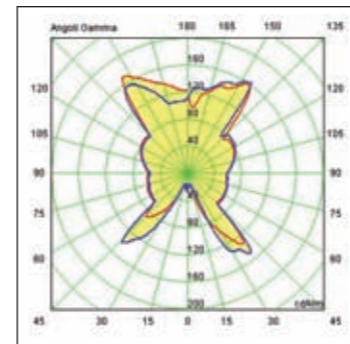

3247TA - 3247TA/R



Amélie

Harry & Camila 2003



Lampada da tavolo. Montatura in metallo verniciato color alluminio. Diffusore in vetro soffiato bianco opalino satinato (BI) o in vetro trasparente azzurro (AZ) o rosso (R).

Table lamp. Structure in metal painted aluminium colour. Diffuser in blown white opal satin (BI) or in transparent light blue (AZ) or red (R) glass.

Lampe de table. Structure en métal verni couleur aluminium. Diffuseur en verre soufflé blanc opalin satiné (BI) ou en verre transparent bleu (AZ) ou rouge (R).

Tischlampe. Struktur aus aluminiumfarbig lackiertem Metall. Mundgeblasen Schirm aus weißem Opalglas (BI) oder transparent in hellblau (AZ) oder rot (R) Farbe.

Lámpara de sobremesa. Estructura de metal pintado color aluminio. Difusor de cristal soplado blanco opalino satinado (BI) o de cristal transparente azul (AZ) o rojo (R).

3490.. AZ - BI - R ø 16 x 26 1x40W (HA) o/or 1x33W (HA) (ES) G9

CE Class II IP20

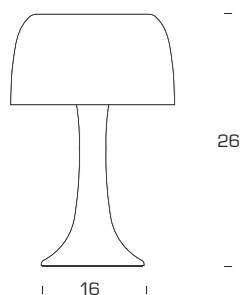

Antoo

Julian Pastorino/Cecilia Suarez 2009



3647BI

3647BI

Lampada da tavolo. Diffusore in vetro soffiato opalino bianco acidato. Montatura in metallo cromato. Cavo di alimentazione, dimmer e spina trasparente.

3647BI

Table lamp. White acid-etched opal blown glass diffuser. Mounting in chrome-plated metal. Transparent feeding cable, dimmer and plug.

3647BI

Lampe de table. Diffuseur en verre soufflé blanc opalin traité avec l'acide. Monture en métal chromé. Câble, dimmer et prise transparents.

3647BI

Tischleuchte. Weißer Leuchtschirm aus geätztem Opalglas. Struktur aus verchromtem Metall. Netzkabel, Dimmer und Netzstecker transparent.

3647BI

Lámpara de sobremesa. Difusor de cristal soplado blanco opalino al ácido. Estructura de metal cromado. Cable eléctrico, dimmer y enchufe transparente.

3648BI

Lampada da tavolo. Diffusore in vetro soffiato opalino bianco acidato. Montatura in metallo verniciato bianco. Cavo di alimentazione, dimmer e spina trasparente.

3648BI

Table lamp. White acid-etched opal blown glass diffuser. Mounting in white painted metal. Transparent feeding cable, dimmer and plug.

3648BI





Lampe de table. Diffuseur en verre soufflé blanc opalin traité avec l'acide. Base en métal verni blanc. Câble, dimmer et prise transparents.

3648BI

Tisch- und Bodenleuchte. Weißer Leuchtschirm aus geätztem Opalglas. Struktur aus weiß lackiertem Metall. Netzkabel, Dimmer und Netzstecker transparent.

3648BI

Lámpara de sobremesa. Difusor de cristal soplado blanco opalino al ácido. Base de metal pintado blanco. Cable eléctrico, dimmer y enchufe transparente.

3647BI	∅ 42,5 x 63	 1x150W [HA]  E27
3648BI	∅ 42,5 x 28	 1x150W [HA]  E27

      IP20



3648BI

3647BI

3648BI

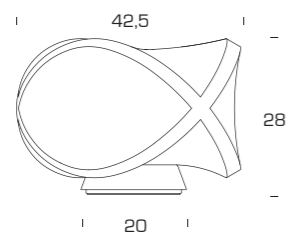
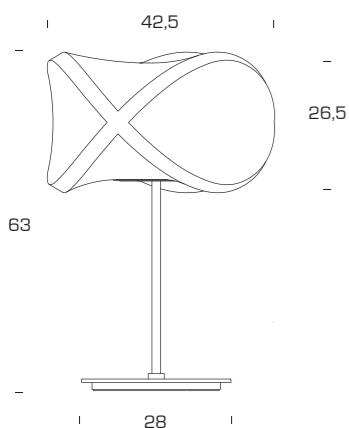

Avion

Marco Acerbis 2009



Lampada da tavolo. Montatura e paralume in nylon verniciato bianco lucido prodotto con tecnologia rotazionale. Disco diffusore superiore in vetro bianco opalino. Base in alluminio pressofuso, verniciata bianca. Alloggia esclusivamente sorgenti luminose fluorescenti.

Table lamp. Mounting and shade in polished white painted nylon, manufactured through rotational moulding process. Upper disc diffuser in opal white glass. Base in die cast aluminium, painted white. It houses fluorescent lighting sources only.

Lampe de table. Monture et abat-jour en nylon verni blanc brillant moulé avec technologie rotationnelle. Disque diffuseur supérieur en verre blanc opalin. Base en aluminium coulé sous pression, vernie en blanc. Elle accueille exclusivement des sources lumineuses fluorescentes.

Tischleuchte mit Gestell und Schirm aus poliertem weiß lackiertem Nylon, im Rotationsverfahren hergestellt. Obere Scheibe aus weißem Opalglas. Basis aus Druckgußaluminium, weiß lackiert Ausschließlich mit Leuchtstofflampen bestückbar.

Lámpara para mesa. Montura y pantalla de nylon pintado blanco pulido producidos con tecnología rotacional. Disco difusor superior de cristal blanco opalino. Base de aluminio moldeado a presión, pintada blanca. Monta exclusivamente fuentes luminosas fluorescentes.

4020BI ø 47 x 75 3x20W (FL) E27

CE IP20

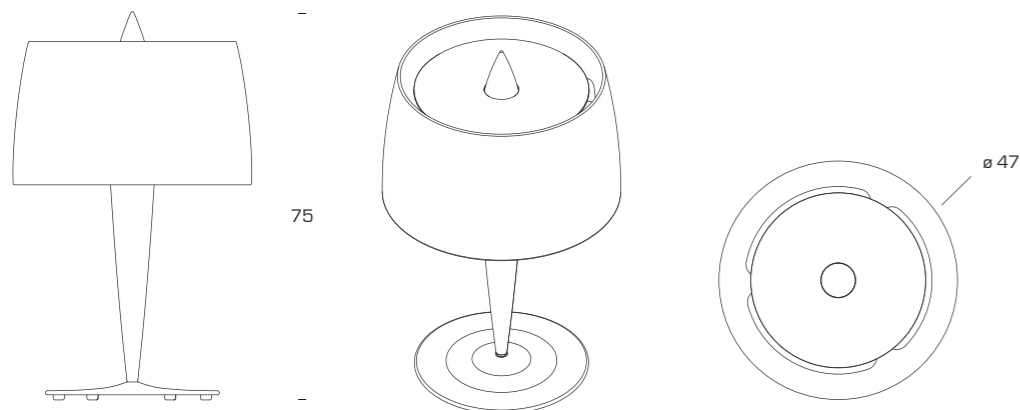

Bilia

Gio Ponti 1931



Poliform, Salone del Mobile, Milano

Lampada da tavolo con dimmer. Montatura in metallo nichelato spazzolato. Diffusore in vetro soffiato bianco satinato. Cavo d'alimentazione, dimmer e spina trasparenti.

Table lamp with dimmer. Brushed nickel-plated metal frame. Diffuser in satin blown white glass. Transparent feeding cable, dimmer and plug.

Lampe de table avec dimmer. Monture en métal nickelé brossé. Diffuseur en verre soufflé blanc satiné. Fil d'alimentation, dimmer et prise transparents.

Tischlampe mit Dimmer. Gestell aus vernickeltem, gebürstetem Metall. Schirm aus geblasenem, weiß-satiniertem Glas. Netzkabel, Dimmer und Stecker transparent.

Lámpara de sobremesa con dimmer. Estructura de metal niquelado cepillado. Difusor de cristal soplado blanco satinado. Cable de alimentación, dimmer y enchufe transparentes.

2474NS ø 20 x 43 1x60W (IN) o/or 1x42W (HA)  E14

   IP20

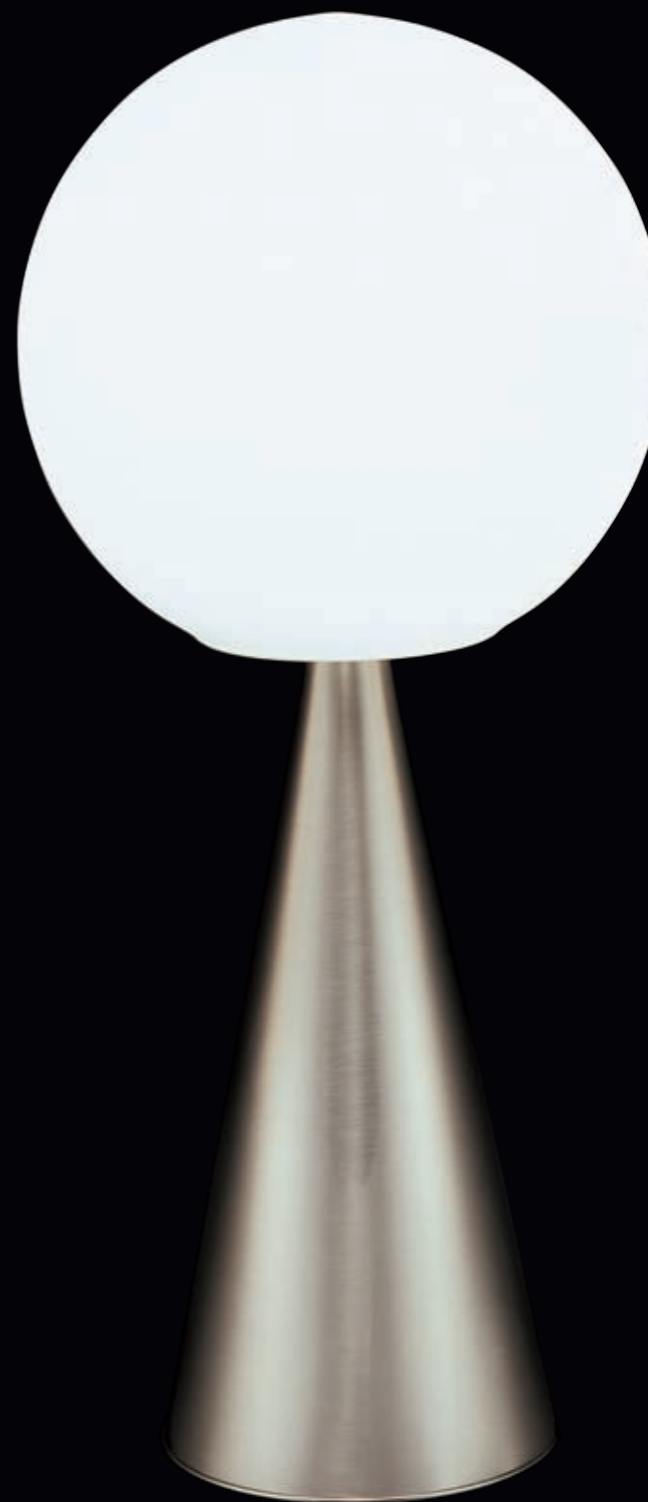
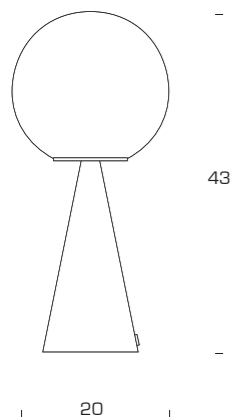

Bis, Tris

Archivio Storico 1950



Bis

Lampada da tavolo. Montatura in ottone lucido. Coppa in vetro opale nero, spessore 6 mm, sabbziata internamente. Diffusore inferiore in vetro bianco smerigliato.

Bis

Table lamp. Polished brass frame. Black opal glass bowl, 6 mm thick, sandblasted on the inside. Lower diffuser in white frosted glass.

Bis

Lampe de table. Monture en laiton brillant. Coupe en verre opale noir, épaisseur 6 mm, sablé intérieurement. Diffuseur inférieur en verre blanc dépoli.

Bis

Tischlampe. Gestell aus poliertem Messing. Schale aus Opalglas, schwarz, Stärke 6 mm, innen Schirm gesandstrahlt. Unterer Schirm aus weißem Mattglas.

Bis

Lámpara de sobremesa. Estructura de latón bruñido. Copa de cristal ópalo negro, espesor 6 mm, arenada interiormente. Difusor inferior de cristal blanco esmerilado.

Tris

Lampada da tavolo. Montatura cromata. Coppa in vetro, spessore 6 mm, sabbziata e verniciata bianca internamente. Diffusore inferiore in vetro bianco smerigliato.

Tris

Table lamp. Chrome-plated frame. Glass bowl, 6 mm thick, sandblasted and painted white on the inside. Lower diffuser in white frosted glass.

Tris

Lampe de table. Monture chromé. Coupe en verre, épaisseur 6 mm, sablé, intérieur verni blanc. Diffuseur inférieur en verre blanc dépoli.

Tris

Tischlampe. Verchromte Messing. Glasschale, Stärke 6 mm, innen gesandstrahlt und weiß lackiert. Unterer Schirm aus weißem Mattglas.

Tris

Lámpara de sobremesa. Estructura cromada. Copa de cristal, espesor 6 mm, arenada y barnizada en blanco interiormente. Difusor inferior de cristal blanco esmerilado.

2280/BIS	∅ 38 x 43	Ⓢ Ⓢ	4x40W (IN) o/or 4x28W (HA) Ⓢ E14
2280/TRIS	∅ 38 x 43	Ⓢ Ⓢ	4x40W (IN) o/or 4x28W (HA) Ⓢ E14

CE Classe # IP20

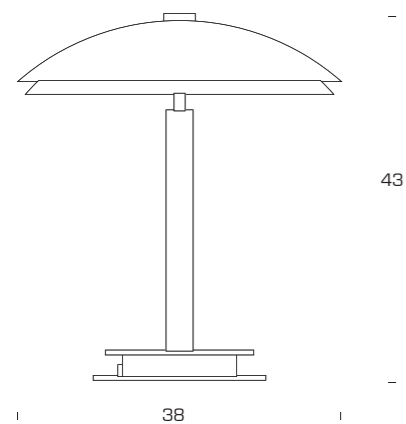

StudioArt, Arzignano (VI), ph. Paolo Veciani

Chiara

Ufficio Tecnico 2003



Lampada da tavolo.
Montatura in acciaio
nichelato spazzolato.
Diffusore in vetro soffiato
bianco opalino.

Table lamp. Structure in
brushed nickel-plated
steel. White opal blown
glass diffuser.

Lampe de table. Structure
en acier nickel brossé.
Diffuseur en verre soufflé
blanc opalin.

Tischlampe. Struktur aus
vernicheltem, gebürste-
tem Stahl. Schirm aus
weißem, mundeblasen-
nem Opalglass.

Lámpara de sobremesa.
Estructura de acero
niquelado cepillado.
Difusor de cristal
soplado blanco opalino.

3504BI ø 11 x 32 1x40W (HA) o/or 1x33W(HA) 

   IP20

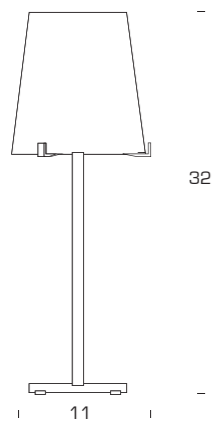

Chignon

Piero Russi 2010



Lampada da tavolo. Diffusore superiore in vetro centrifugato tipo midollino metallizzato esternamente. Diffusore inferiore in vetro soffiato bianco opalino acidato. Struttura e puntale cilindrico per il blocco del diffusore in metallo cromato.

Table lamp. Upper diffuser in spinning glass "midollino"-type with external metal sheathing. Lower diffuser in opal white blown acid-etched glass. Structure and cylindrical handgrip for the fixing of the diffuser in chrome-plated metal.

Lampe de table. Diffuseur supérieur en verre centrifugé type Midollino métallisé à l'extérieur. Diffuseur inférieur en en verre soufflé blanc opalin acidé. Structure et embout cylindrique pour bloquer le diffuseur en métal chromé.

Tischleuchte. Oberer Streukörper aus zentrifugiertem Glas Typ "midollino", außen metallisiert. Unterer Streukörper aus weißem opal geätztem Glas. Gestell und zylindrische Metallspitz aus verchromtem Metall.

Lámpara de mesa. Difusor superior de vidrio centrifugado, tipo midollino metalizado externamente. Difusor inferior de vidrio soplado blanco opalino al ácido. Estructura y extremidad cilíndrica para el bloqueo del difusor en metal cromado.

4033BI/CR

∅ 20 x 60



3x40W (HA) ES G9

     Classe II IP20

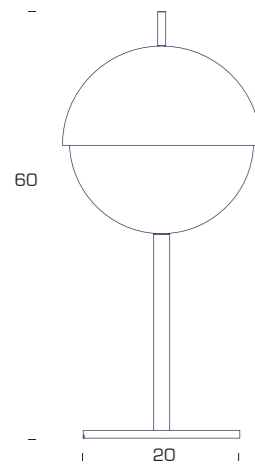

Daruma

Sergio Asti 1968



















Lampada da tavolo.
Diffusori in vetro soffiato
bianco lucido.

Table lamp. Diffusers in
polished white blown
glass.

Lampe de table.
Diffuseurs en verre soufflé
blanc poli.

Tischlampe. Schirme aus
weißem geblasenem
poliertem Glas.

Lámpara de sobremesa.
Difusores de cristal
soplado blanco lúcido.

5028	∅ 16 x 17	 	1x25W (IN) o/or 1x18W (HA) ES E27
5028/1	∅ 19 x 20	  	1x25W (IN) o/or 1x18W (HA) ES o/or 1x5W (FL) E27
5028/2	∅ 23 x 24	  	1x40W (IN) o/or 1x28W (HA) ES o/or 1x12W (FL) E27
5028/3	∅ 28 x 29	  	1x60W (IN) o/or 1x42W (HA) ES o/or 1x12W (FL) E27
5028/4	∅ 34 x 36	  	1x75W (IN) o/or 1x70W (HA) ES o/or 1x20W (FL) E27
5028/5	∅ 40 x 42	 	1x100W (HA) ES o/or 1x20W (FL) E27

   IP20

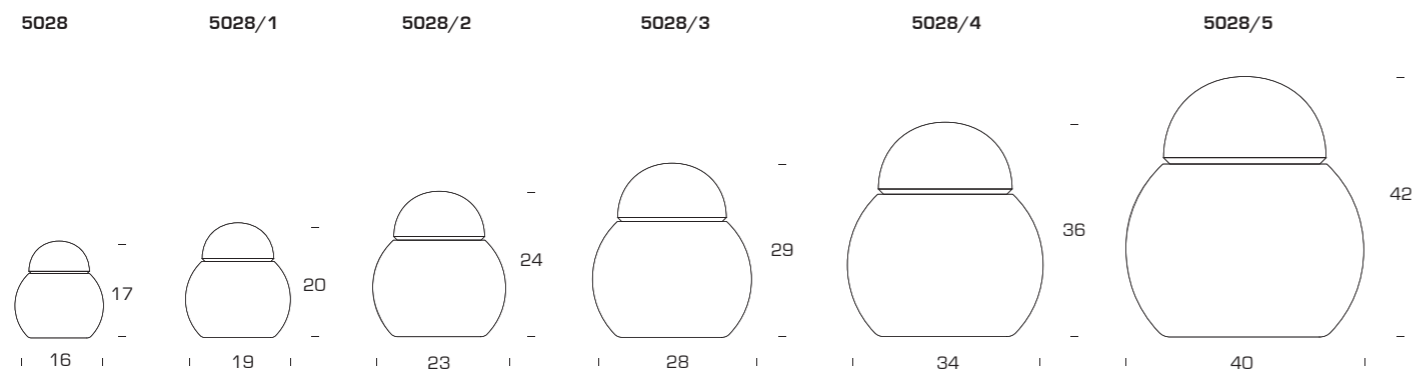

Drum

Franco Raggi 2005

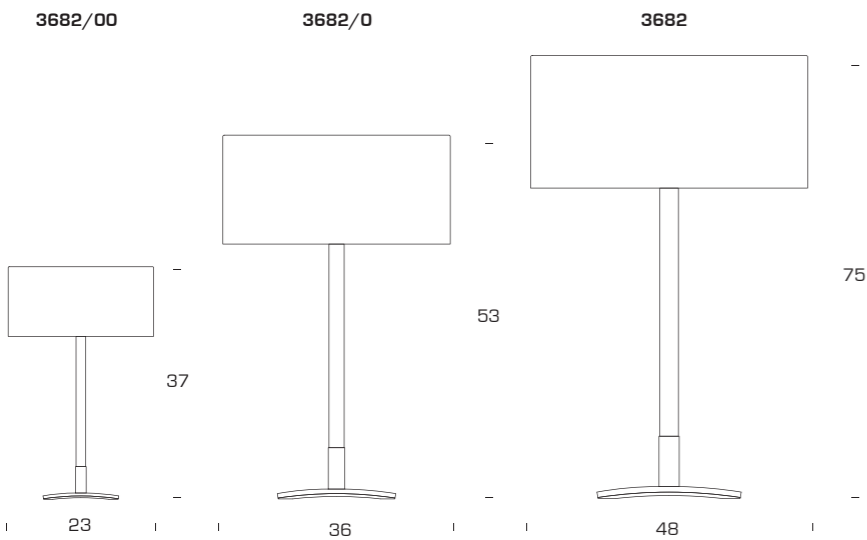

Lampada da tavolo con dimmer. Diffusore in vetro soffiato bianco acidato. Base in acciaio lucido con stelo in vetro borosilicato trasparente. Cavo, dimmer e spina trasparenti.

Table lamp with dimmer. White acid-etched blown glass diffuser. Polished steel base with transparent borosilicate glass stem. Transparent cable, dimmer and plug.

Lampe de table avec dimmer. Diffuseur en verre soufflé blanc traité avec l'acide. Base en acier poli, tige en verre borosilicate transparent. Câble, dimmer et fiche transparents.

Tischlampe mit Dimmer. Schirm aus weißem mundgeblasenem Ätzglas. Sockel aus Glanzstahl mit Stab aus transparentem Borosilikatglas. Netzkabel, Dimmer und Netzstecker transparent.

Lámpara de sobremesa con dimmer. Difusor de cristal soplado blanco al ácido. Base de acero brillante con barra de soporte de vidrio borosilicato transparente. Cable, dimmer y enchufe transparente.

3682/00	∅ 23 x 37	3x25W (HA) o/or 3x20W (HA) (ES) G9
3682/0	∅ 36 x 53	3x40W o/or 3x33W (HA) (ES) G9
3682	∅ 48 x 75	3x60W (HA) E14

CE Class II IP20

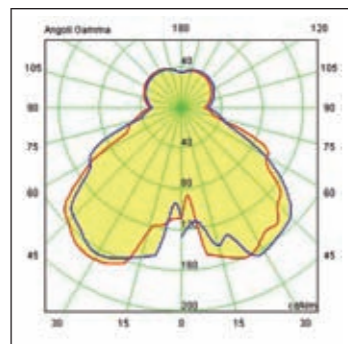

3682/0

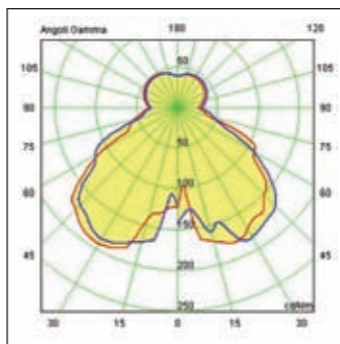

3682



Elvis

Charles Williams 1998



Lampada da tavolo.
Montatura in ottone
cromato. Diffusore in
metacrilato con inserti
di tessuto bianco (BI)
o blu (BL).

M5265
montatura
P5265.. BI - BL
diffusore

Table lamp. Chrome-
plated brass mounting.
Shade in methacrylate
with white (BI) or blue (BL)
fabric inserts.

M5265
mounting
P5265.. BI - BL
shade

Lampe de table. Monture
en laiton chromé Diffuseur
en méthacrylate avec
applications en tissu blanc
(BI) ou bleu (BL).

M5265
monture
P5265.. BI - BL
abat-jour

Tischlampe. Gestell aus
verchromtem Messing.
Methacryl-Schirm mit
Einlässen aus weißem (BI)
oder blauem (BL) Stoff.

M5265
Gestell
P5265.. BI - BL
Lampenschirm

Lámpara de sobremesa.
Estructura de latón
cromado. Pantalla de
metacrilato con aplicacio-
nes de tejido blanco (BI) o
azul (BL).

M5265
estructura
P5265.. BI - BL
pantalla

M5265 + P5265.. BI - BL 34 x 18 x 59 1x100W (HA) E27

CE IP20

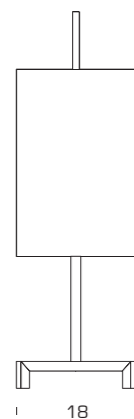
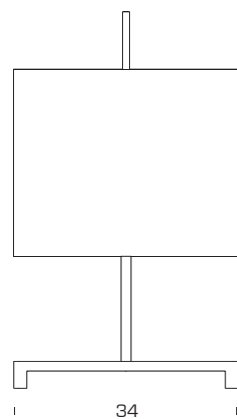

59



Falena

Alvaro Siza 1994



Lampada da tavolo a bassa tensione con trasformatore elettronico a spina e interruttore sul cavo per doppia intensità. Base in vetro molato. Corpo orientabile 360° sul piano orizzontale, in metallo cromato. Alette diffusori, orientabili, in alluminio anodizzato. Il collegamento elettrico fra la base e il corpo avviene tramite jack.

Low voltage table lamp with electronic plug-type transformer and switch on the cable for double light intensity. The body in chrome-plated metal rotates 360° on the horizontal plane. Revolving diffuser wings in anodized aluminium. Thick polished glass base. A jack allows the electric connection between the base and the body.

Lampe de table à basse tension, avec transformateur électronique à prise et avec interrupteur à double intensité sur le câble. Corps tourné à 360° sur le plan horizontal en métal chromé. Diffuseurs à ailettes orientables en aluminium anodisé. Base en verre biseauté. La connexion électrique entre la base et le corps est assurée par le biais d'une douille-jack.

Niederspannung Tischlampe mit elektronischem Trafo mit Stecker und Schalter auf dem Kabel für doppelte Schaltung. Basis aus geschliffenem Glas. Um 360° drehbarer Körper aus verchromtem Metall. Verstellbare Flügel-Schirme aus eloxiertem Aluminium. Verbindung zwischen Basis und Körper durch Einschaltklinge.

Lámpara de sobremesa de baja tensión con transformador electrónico de clavija e interruptor en el cable para doble intensidad. El cuerpo de metal cromado gira 360° sobre el plano horizontal. Aletas difusoras orientables de aluminio anodizado. Base de cristal esmerilado. La conexión entre a base y el cuerpo se produce mediante jack.

3016
corpo
3017
base

3016
body
3017
base

3016
corps
3017
base

3016
Körper
3017
Basis

3016
cuerpo
3017
base

3016 + 3017 ø 19 x 40 x 52 1x50W [HA] o/ or 1x35W [HA] (ES) GY6.35

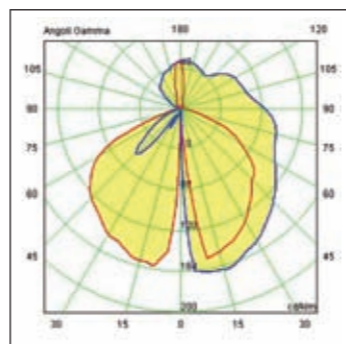
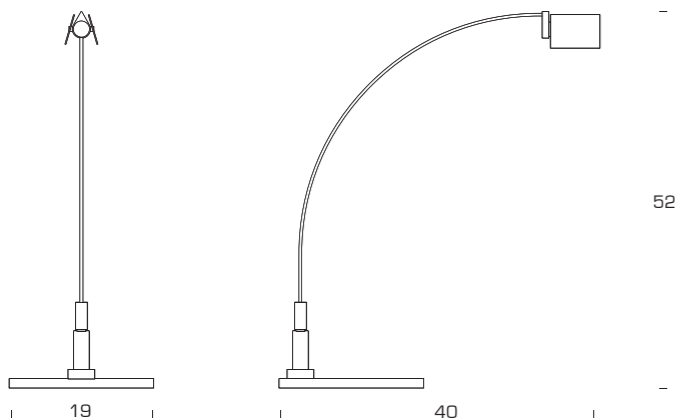

Fontana

Max Ingrand 1954







Lampada da tavolo a doppia o tripla accensione. Montatura in metallo verniciato bianco. Paralume e base in vetro soffiato bianco satinato. Cavo d'alimentazione e interruttore nero.

Double-switch or triple-switch table lamp. White-painted metal frame. Shade and globe in satin white blown glass. Black feeding cable and switch.

Lampe de table à double ou triple allumage. Monture en métal verni blanc. Abat-jour et globe en verre soufflé blanc satiné. Câble d'alimentation et interrupteur noirs.

Tischlampe mit Doppel- oder Dreifach-Schaltung. Gestell aus weißem lackiertem Metall. Lampenschirm und Lampenglocke aus weißem, geblasenem satiniertem Glas. Netzka- bel und Schalter, schwarz.

Lámpara de sobremesa con cebado doble o triple. Estructura de metal pintado blanco. Pantalla y globo de cristal soplado blanco satinado. Cable de alimentación y interruptor negro.

1853/0	∅ 20 x 34		1x60W (IN) o/or 1x16W (FL) E27+ 2x25W (HA) o/or 2x20W (HA) 
1853	∅ 32 x 53		1x20W (FL) E27 + 2x40W (IN) E14
1853/1	∅ 47 x 78		4x60W (IN) o/or 4x20W (FL) E27+1x100W (HA)  E27+2x40W (IN) E14

   IP20

1853  



1853/0 doppia accensione / double switching / double allumage / Doppelschaltung / cebado doble

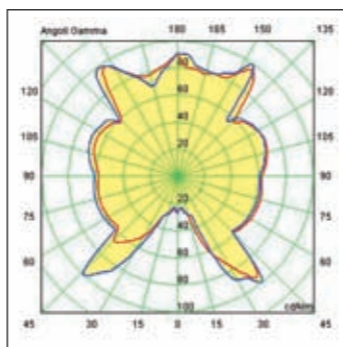
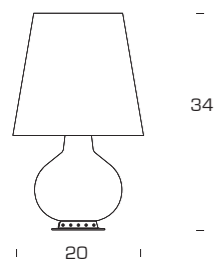

1853 doppia accensione / double switching / double allumage / Doppelschaltung / cebado doble

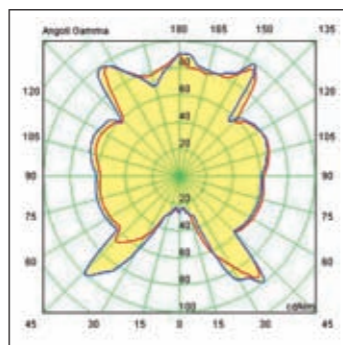
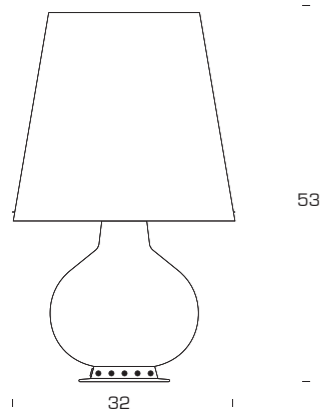

1853

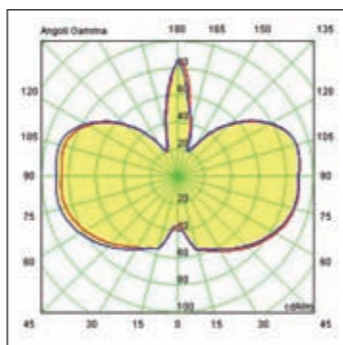

1853 globo / globe

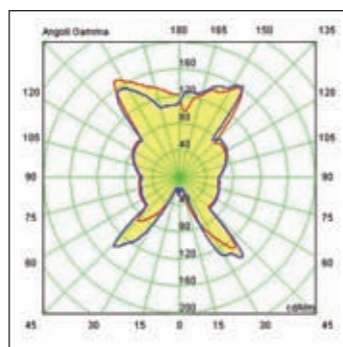

1853 paralume / shade

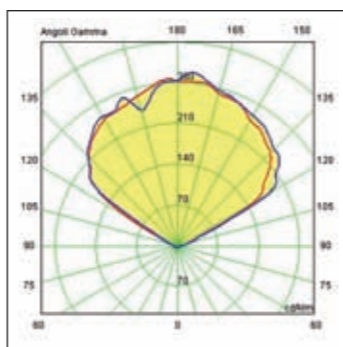

1853 parabola / parabola

1853/1 tripla accensione / triple switching / triple allumage / Dreifachschaltung / cebado triple

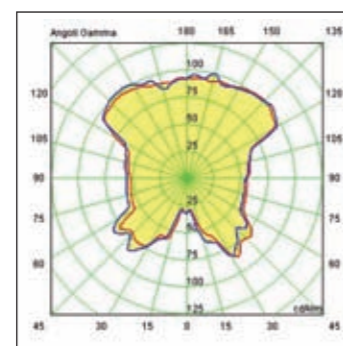
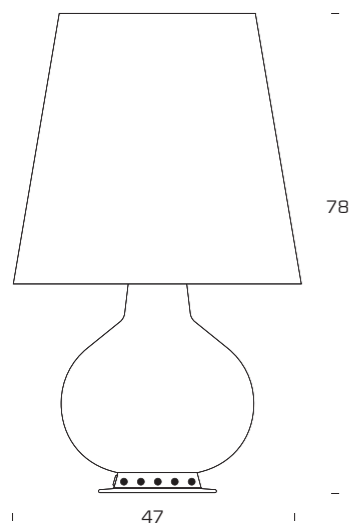

1853/1

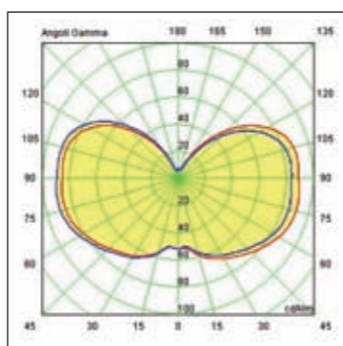

1853/1 globo / globe

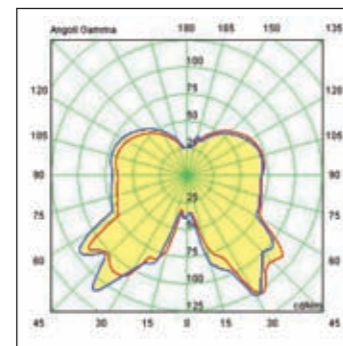

1853/1 paralume / shade

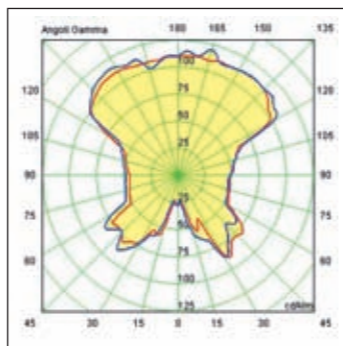

1853/1 parabola + paralume / parabola + shade



Giova

Gae Aulenti 1964



Lampada/portafiori da tavolo. Base in metallo cromato. Sfera centrale in vetro trasparente soffiato. Sfera interna in vetro bianco opalino lucido. Semisfera superiore in vetro soffiato rosa con bollicine decorative.

Table lamp/flower pot. Chrome-plated metal base. Middle globe in transparent blown glass. Internal globe in polished white opal glass. Upper half sphere in pink blown glass with bubbles inside.

Lampe de table/porte-bouquet. Base en métal chromé. Sphère centrale en verre transparent soufflé. Sphère interne en verre blanc opalin poli. Demi-sphère supérieure en verre soufflé rose avec bulles.

Tischlampe/Blumenvase. Sockel aus verchromtem Metall. Mittlere Kugel aus transparentem, geblasenem Glas. Innere Kugel aus weißem Opalglas. Obere Halbkugel aus geblasenem rosafarbenem Glas mit Bläschen.

Lámpara/jarrón de sobremesa. Base de metal cromado. Esfera central de cristal transparente soplado. Esfera interna de cristal blanco opalino. Semiesfera superior de cristal soplado rosa con gorgoritas.

2684	∅ 32 x 37		1x60W (IN) o/or 1x42W (HA) (ES) E27
2684/1	∅ 50 x 59		1x100W (HA) (ES) E27

IP20

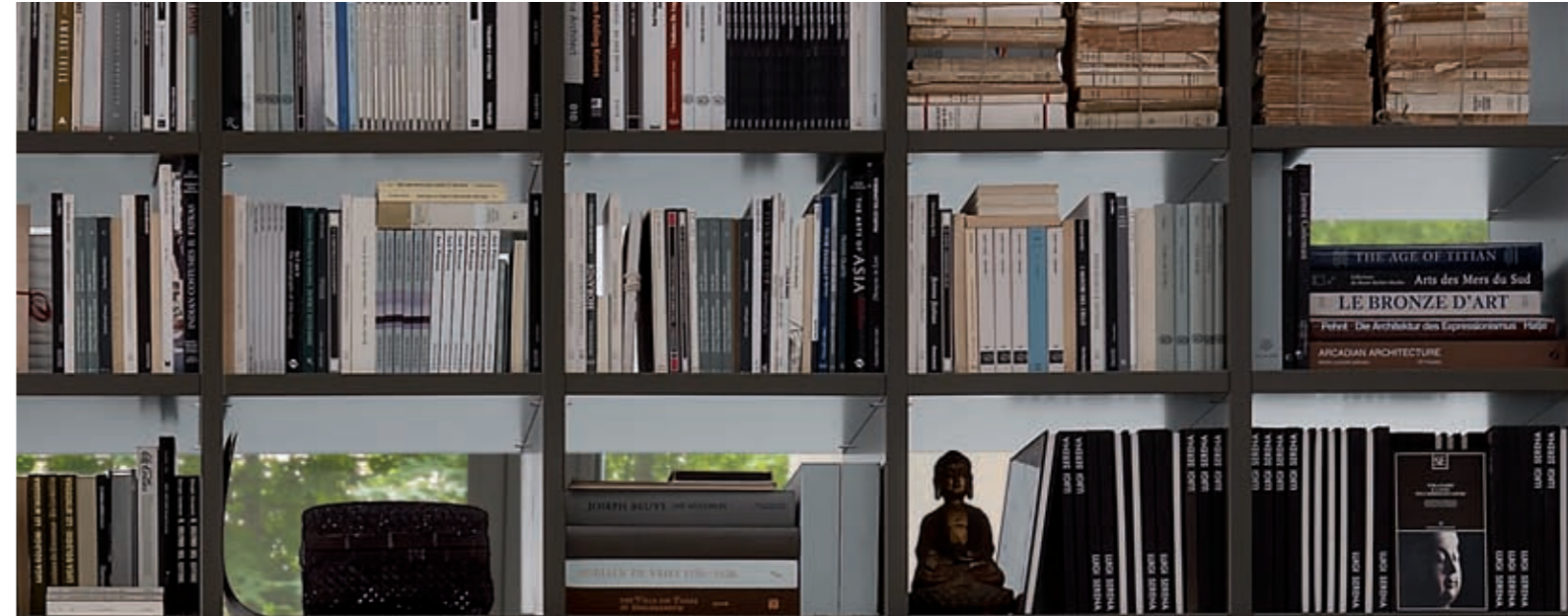
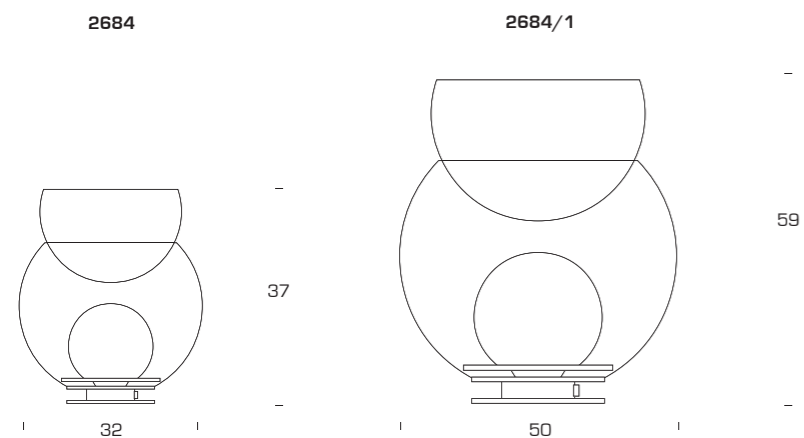

Jesse, Francanigo (TV)



Globo di Luce

Roberto Menghi 1968



Lampada da tavolo con dimmer. Globo in vetro soffiato metallizzato. Base in metallo cromato. Riflettore interno in alluminio anodizzato. Cavo elettrico, dimmer e spina trasparenti.

Table lamp with dimmer. Metallised blown glass globe. Chrome-plated metal base. Anodised aluminium internal reflector. Transparent electric cable, dimmer and plug.

Lampe de table avec dimmer. Globe en verre soufflé métallisé. Base en métal chromé. Réflecteur interne en aluminium anodisé. Fil d'alimentation, dimmer et prise transparents.

Tischlampe mit Dimmer. Kugel aus mundgeblasenem metallisiertem Glas. Sockel aus verchromtem Metall. Innenreflektor aus eloxiertem Aluminium. Kabel, Dimmer und Stecker transparent.

Lámpara de sobremesa con dimmer. Globo de cristal soplado metalizado. Base en metal cromado. Reflector interior de aluminio anodizado. Cable, dimmer y enchufe transparente.

3667/1 ø 45 x 47 1x150W (HA) **ES**E27

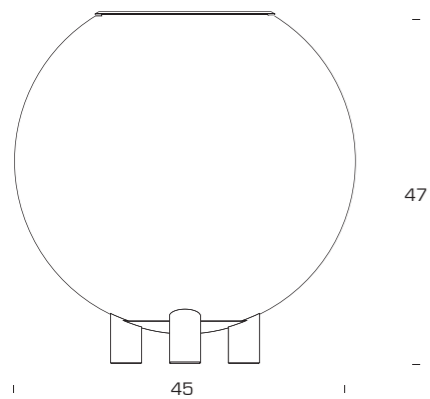

Loop

Voon Wong / Benson Saw 2003



Lampada da tavolo.
Struttura in acciaio
inox lucidato. Diffusione
della luce mediante
rotazione della parte
superiore della struttura.

Table lamp. Structure in
polished stainless steel.
Adjustable light diffusion
through rotation of upper
part of the structure.

Lampe de table. Structure
en acier inox poli. Diffusion
de la lumière par rotation
de la partie supérieure de
la structure.

Tischlampe. Struktur aus
rostfreiem Stahl.
Lichtschirm durch
Drehen des oberen
Strukturteils.

Lámpara de sobremesa.
Estructura de acero inox
bruñido. Difusión de la luz
mediante rotación de la
parte superior de la
estructura.

5429AXL

∅ 50 x 17



1x40W (FL) 2GX13

CE IP20

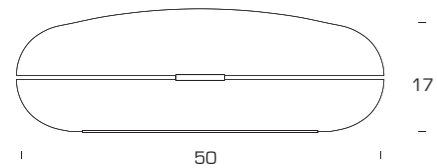



Margaret

Vico Magistretti 2000

Lampada da appoggio (per spalliera letto, divano, ecc.). Riflettore in alluminio brillantato e lucidato. Tige telescopica in ottone cromato. Sacca d'appoggio in pelle stampata marrone (MA) o nera (N).

Lamp with supporting bag (to be put on the head of a bed, a sofa, etc.). Polished and buffed aluminium reflector. Chrome-plated brass telescopic stem. Brown (MA) or black (N) printed leather supporting bag.

Lampe d'appui (pour dossier de lit, de canapé, etc.). Réflecteur en aluminium brillanté et poli. Tige télescopique en laiton chromé. Sac d'appui en marron (MA) ou noir (N).

Lampe mit einer Stütztasche (für das Kopfende von einem Bett, Sofa usw.). Reflektor aus poliertem und geschliffenem Aluminium. Teleskopstiel aus verchromtem Messing. Stütztasche aus braunem (MA) oder schwarzem (N) bedrucktem Leder.

Lámpara supletoria (para cabecera cama, sofá etc.). Foco de aluminio brillante y bruñido. Varilla telescópica de latón cromado. Bolsa de apoyo de piel grabada marrón (MA) o negro (N).

5291.. MA - N 14 x 8 x 44 (max 66) 1x9W (FL) E14

CE Class II IP20

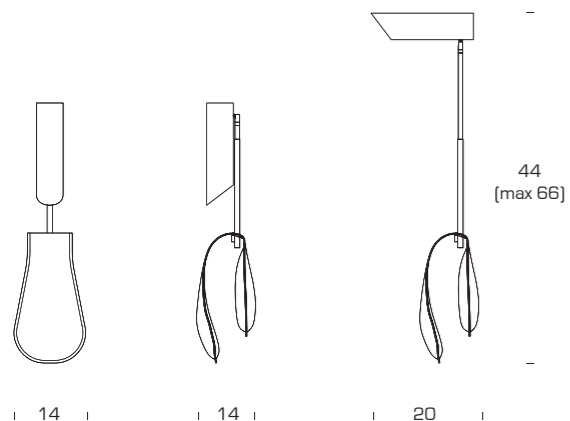

Naska 1, 2 Nasketta

1933



Porro Industrie Mobili, Salone del Mobile, Milano

Famiglia di lampade con braccio orientabile in tutte le direzioni in versione da tavolo, da morsetto e con supporto fisso. Base e stelo in acciaio, parabola in alluminio, il tutto verniciato nei colori alluminio (A), bianco (BI), cromato (CR) o nero opaco (NO). Disponibile anche nella versione Led.

Family of lamps with revolving bracket in all directions. Table, clamp and fixed support version. Base and stem in steel. Aluminium parabola. Painted in the following colours: aluminium (A), white (BI), chrome-plated (CR) or opal black (NO). Available in the Led version too.

Famille de lampes avec bras orientable dans toutes les directions en version de table, à étau et avec support fixe. Base et tige en acier, parabole en aluminium, vernis aluminium (A), blanc (BI), chromé (CR) ou noir opaline (NO). Disponible aussi à la version Led.

Lampenfamilie mit in allen Richtungen orientierbaren Arm. Tisch-, Klemm- und mit festem Sockel version. Sockel und Stiel sind aus Stahl, die Parabel ist aus Aluminium. Sie sind aluminiumfarben (A), weiß (BI), chrom (CR) oder opal schwarz (NO) lackiert. Verfügbar auch die Version mit Led.

Familia de lámparas con brazos orientables en todas las direcciones en versión sobremesa, pinza y soporte fijo. Base y varilla de acero, parábola de aluminio pintado en color aluminio (A), blanco (BI), cromado (CR) o negro opaco (NO). Disponible también la versión con Led.

8000..	corpo / body / corps / Körper / cuerpo		1x60W (IN) o/or 1x42W (HA)	E27
8001..	corpo / body / corps / Körper / cuerpo		1x60W (IN) o/or 1x42W (HA)	E27
8004..	corpo / body / corps / Körper / cuerpo		1x40W (IN) o/or 1x28W (HA)	E27
8010.* A - BI - CR - NO	corpo / body / corps / Körper / cuerpo	o	3x3W 700mA (Led)	
8011.* A - BI - CR - NO	corpo / body / corps / Körper / cuerpo	o	3x3W 700mA (Led)	

8000.. - 8001.. - 8004.. * temperatura di colore / colour temperature / température de couleur / Farbtemperatur / temperatura de color 3000°K
alimentatore incluso / ballast included / alimentateur inclus / Vorschaltgerät inbegriffen / alimentador incluido

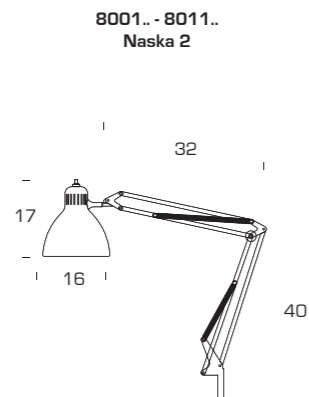
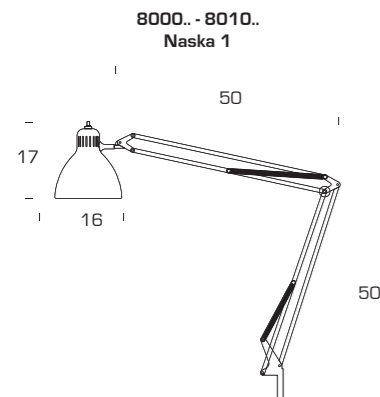

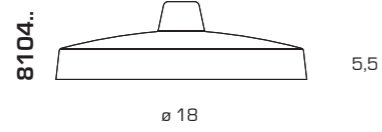
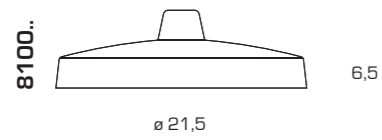

Naska 1, 2
8100.. A - BI - CR - NO

Nasketta
8104.. A - BI - CR - NO

base per tavolo / base for table / base pour table /
Sockel für Tisch / base para sobremesa

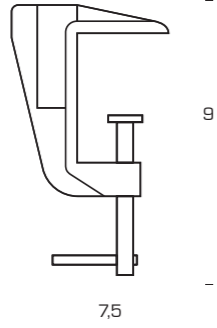

8101.. A - BI - CR - NO

morsetto / clamp / étau / Klemme / pinza

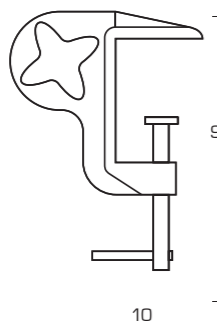

8102.. A - BI - CR - NO

morsetto per piano inclinato /
clamp for sloping level / étau pour plan incliné /
Klemme für schräge Oberfläche /
pinza para superficie inclinada

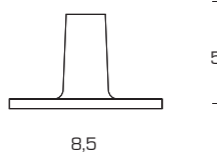

8104.. A - BI - CR - NO

attacco fisso / fixed clamp /
attache fixe / fester Sockel / enganche fijo

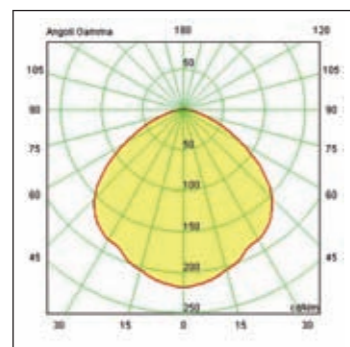

8000..

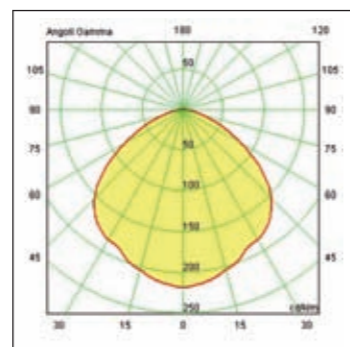

8001..

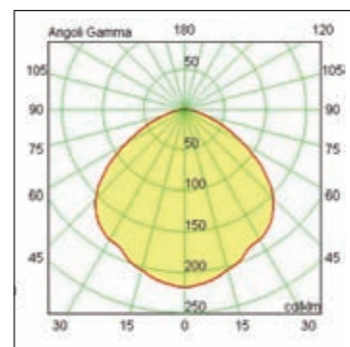

8004..





Parola

Gae Aulenti / Piero Castiglioni 1980



Alivar, Salone del Mobile, Milano

Lampada da tavolo con dimmer. Base in vetro trasparente e stelo in vetro borosilicato. Diffusore in vetro soffiato opalino ambra (AM) oppure bianco (BI).

Table lamp with dimmer. Base in transparent glass and stem in borosilicate glass. Diffuser in amber (AM) or white (BI) opal blown glass.

Lampe de table avec dimmer. Base en verre transparent et tige en verre borosilicate. Diffuseur en verre soufflé opalin couleur ambre (AM) ou blanc (BI).

Lampe de table avec dimmer. Base en verre transparent et tige en verre borosilicate. Diffuseur en verre soufflé opalin couleur ambre (AM) ou blanc (BI).

Lámpara de sobremesa con dimmer. Base de cristal transparente y pie de vidrio borosilicato. Difusor de cristal soplado opalino ámbar (AM) or blanco (BI).

M2658
base
V2689.. AM - BI
diffusore

M2658
base
V2689.. AM - BI
diffuser

M2658
base
V2689.. AM - BI
diffuseur

M2658
base
V2689.. AM - BI
diffusor

M2658
base
V2689.. AM - BI
difusor

M2658 + V2689.. AM-BI ø 20 x 53 1x150W (HA) (ES) B15d

CE Classe II IP20

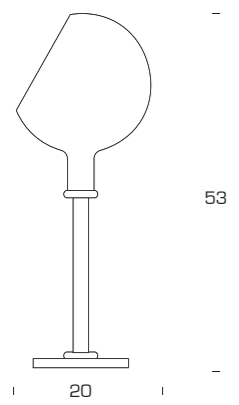

Passion

Studio Beretta 2004

3610/00.

3610/0.

3610.

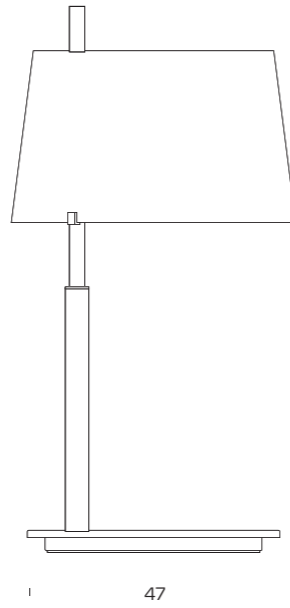
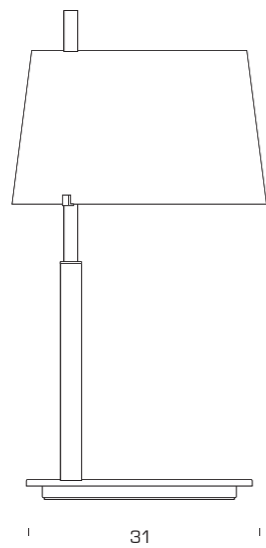
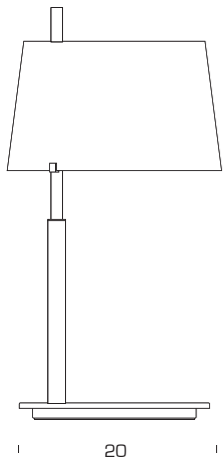

Lampada da tavolo con dimmer. Montatura in ottone cromato (CR) o nichelato spazzolato (NC). Diffusore in vetro bianco opalino, soffiato e satinato. Riflettore superiore in metallo.

Table lamp. Chrome-plated (CR) or brushed nickel-plated (NC) brass frame. Diffuser in white satin blown glass. Metal upper reflector.

Lampe de table. Structure en laiton chromé (CR) ou nickelé brossé (NC). Diffuseur en verre blanc, soufflé et satiné avec réflecteur supérieur en métal.

Tischlampe mit Dimmer. Struktur aus verchromtem (CR) oder vernickeltem Messing (NC). Schirm in weißem geblasenem satiniertem Glas mit Metall Reflektor.

Lampara de sobremesa. Montura de latón cromado (CR) o niquelado (NC). Difusor en cristal blanco, soplado y satinado con reflector de aluminio.

3610/00.. CR - NC	ø 20 x 36	1x60W (HA) o/ or 1x48W (HA) (ES) G9
3610/0.. CR - NC	ø 31 x 60	1x150W (HA) (ES) o/ or 1x20W (FL) E27
3610.. CR - NC	ø 47 x 87	2x100W (HA) (ES) o/ or 2x20W (FL) E27

CE IP20 3610/0.. UL

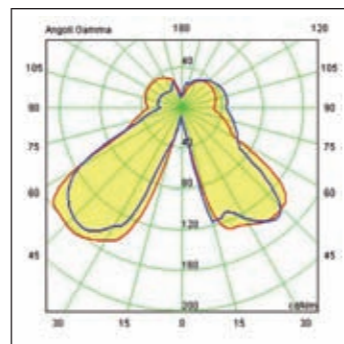

3610/00.

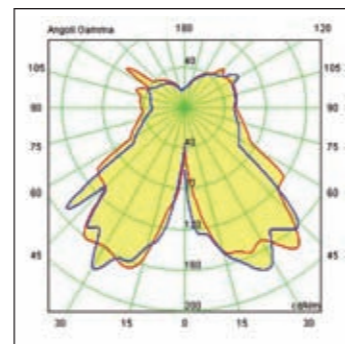

3610..



Pirellina

Gio Ponti 1967



Lampada da tavolo con dimmer. Montatura in fusione di ottone nichelato. Diffusori in vetro stampato e curvato. Cavo elettrico, dimmer e spina trasparenti.

Table lamp with dimmer. Nickel-plated cast brass frame. Diffuser in curved pressed glass. Transparent feeding cable, dimmer and plug.

Lampe de table avec dimmer. Monture en laiton nickelé moulé. Diffuseur en verre pressé et bombé. Fil d'alimentation, dimmer et prise transparents.

Tischlampe mit Dimmer. Gestell aus vernickeltem Messingguss. Schirme aus gebogenem Pressglas. Netzkabel, Dimmer und Stecker transparent.

Lámpara de sobremesa con dimmer. Estructura de fusión de latón niquelado. Difusor de cristal grabado y curvado. Cable de alimentación, dimmer y enchufe transparentes.

2781	17 x 8 x 39		4x25W (IN) o/ or 4x18W (HA) (ES) E14
2781/1	34 x 17 x 70		6x40W (IN) o/ or 6x28W (HA) (ES) E14

Classe # IP20

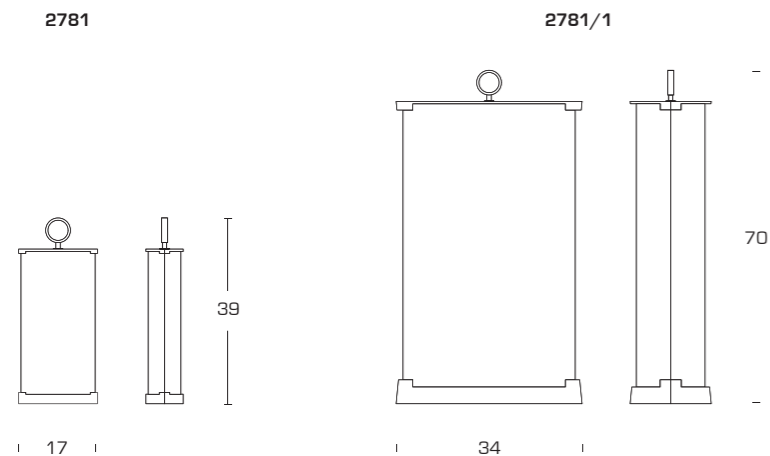

Curtis / Mallet-Prevost / Colt & Mosie Iip, Milano



Sara

Pierluigi Cerri (Gregotti Associati) 1993



Lampada da tavolo. Montatura in metallo colore alluminio con diffusore in policarbonato colore avorio serigrafato internamente (A) oppure montatura in metallo cromato con diffusore in policarbonato bianco ottico (CR/BI).

Table lamp. Mounting in grey colour aluminium with polycarbonate diffuser in ivory colour, silkscreened inside (A) or mounting in chrome-plated metal with white optical diffuser in polycarbonate (CR/BI).

Lampe de table. Monture en métal verni aluminium avec diffuseur en polycarbonate couleur ivoire, sérigraphié intérieurement (A) ou monture en métal chromé avec diffuseur en polycarbonate couleur blanc optique (CR/BI).

Tischlampe. Gestell aus aluminiumfarbenem Metall mit Schirm aus Elfenbeinfarbenem Polykarbonat, innen siebgedruckt (A) oder Gestell aus verchromtem Metall mit Schirm aus weißem optischem Polykarbonat (CR/BI).

Lámpara de sobremesa. Estructura de metal pintado color aluminio con difusor de policarbonato blanco marfil, serigrafado en el interior (A) o estructura de metal cromado con difusor de policarbonato blanco óptico (CR/BI).

5139.. A - CR/BI 22 x 13 x 47 1x60W (IN) o/or 1x42W (HA) E14

CE IP20

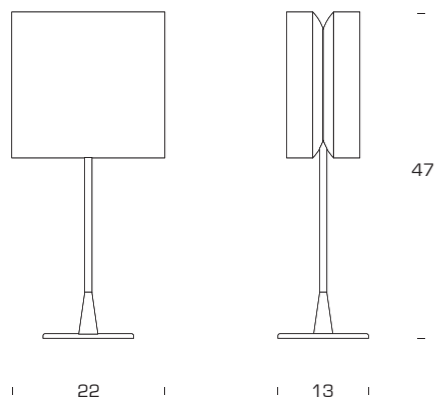

Thor

Luciano Pagani / Angelo Perversi 2000





Lampada da tavolo.
Montatura in metallo verniciato bianco. Diffusore in vetro soffiato bianco opale.

Table lamp. White painted metal frame. Opal white blown glass diffuser.

Lampe de table. Monture en métal verni blanc. Diffuseur en verre soufflé couleur blanc opale.

Tischlampe. Gestell weißem lackiertem Metal. Schirm aus weißem geblasenem Mattglas.

Lámpara de sobremesa. Estructura de metal pintado blanco. Difusor de cristal soplado blanco mate.

3295/0	33 x 11 x 20		1x40W (IN) o/or 1x8W (FL) E14
3295	39 x 13 x 25		1x60W (IN) o/or 1x16W (FL) E27

   IP20

3295/0

3295

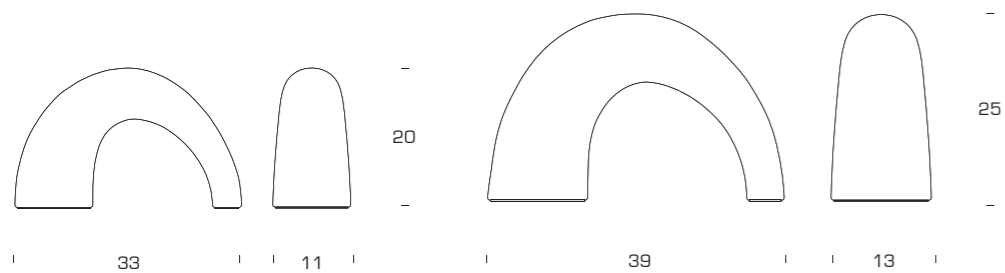

Three Sixty

Foster + Partners 2005

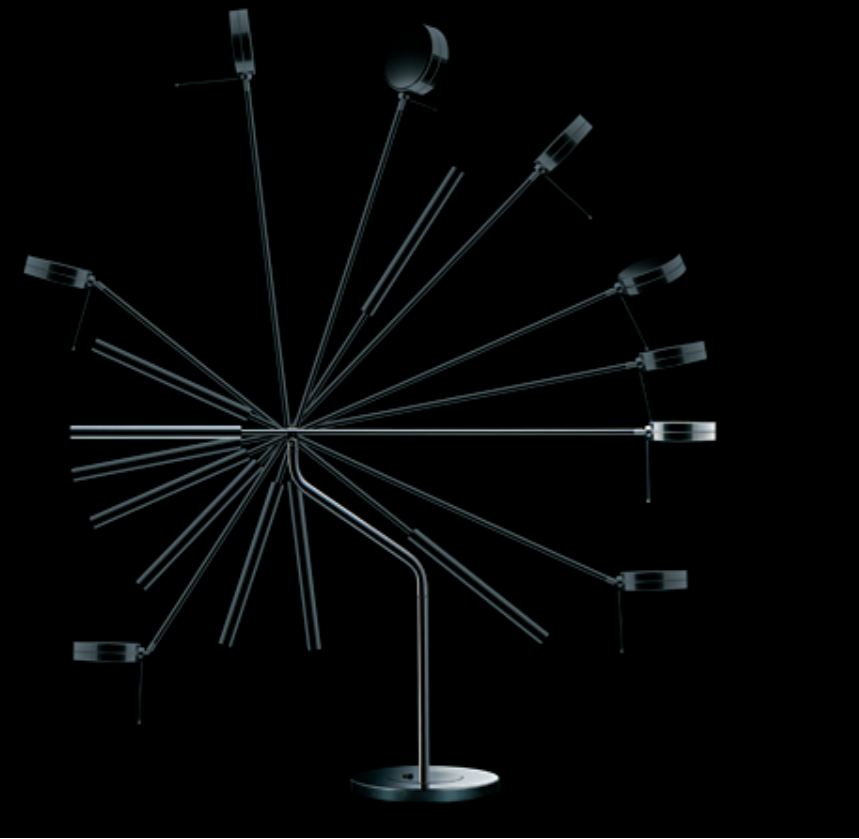

Lampada da tavolo. Struttura in ottone, base e zavorra in zama, parabola in resina. Disponibile verniciata alluminio (A), bianco opaco (BI), cromato (CR) e grigio scuro (GS). Due snodi brevettati collocati nella base e sul braccio consentono alla lampada una rotazione complessiva di 300°. La testa, ruotabile di 360°, permette di orientare il flusso luminoso in tutte le direzioni.

Table lamp. Structure in brass, base and ballast in in zamac metal alloy. Parabola in resin. Available painted aluminium (A), matt white (BI), chrome-plated (CR) and dark grey (GS). Two patent pending joints situated in the base and on the arm allow the appliance to be rotated 300°. The head, 360° adjustable, allows the lighting beam to be orientated in all the directions.

Lampe de table. Structure en laiton. Base et lest en zamac. Parabole en résine. Le tout verni dans les couleurs: aluminium (A), blanc mat (BI) ou gris foncé (GS). Deux pivots brevetés, disposés sur la base et sur la tige permettent à la lampe une rotation de 300°. La tête, elle aussi rotatable à 360°, donne la possibilité d'ajuster la diffusion de la lumière dans toutes les directions.

Tischleuchte. Struktur aus Messing, Basis und Ballast aus Zink-Aluminium-Magnesium-Legierung, Parabel aus Kunstharz. In folgenden Farben lackiert: aluminiumfarben (A), mattweiß (BI), verchromt (CR) und dunkelgrau (GS). Zwei patentierte Gelenke ermöglichen eine 300° Rotation der Leuchte. Dank einem ausrichtbaren Leuchtenkopf kann die Lichtverteilung in alle Richtungen orientiert werden.

Lámpara de sobremesa. Estructura de latón. Base y contrapeso en zamac. Aleación metálica de zinc. Parábola de resina. Acabados: aluminio (A), blanco mate (BI), cromado (CR) o gris oscuro (GS). Dos articulaciones una en la base y una en el brazo admiten una rotación total de la lámpara de 300°. La cabeza, orientable de 360°, admite l'orientación del flujo luminoso en todas direcciones.

Modello comunitario depositato

Design patent pending

Modèle communautaire déposé

Eingetragenes Warenzeichen

Modelo comunitario depositado

5474.. A - BI - CR - GS 93 x 22 x 54 (max 82) ⇒ 1x50W (HA) o/or 1 x35W (HA) (ES) GY6.35

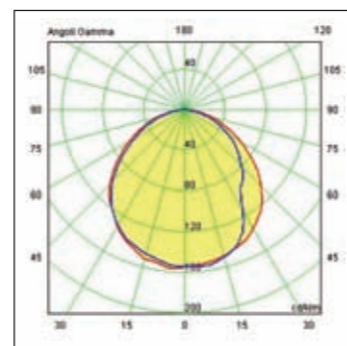
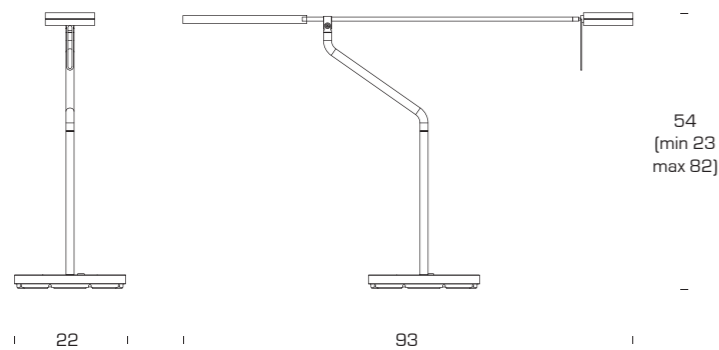

Time 21:00

Studio Parisotto / Formenton 2006



Lampada da tavolo con doppia emissione luminosa, diffusa e concentrata. Struttura in alluminio estruso anodizzato satinato (A) o anodizzato satinato nero (N). Diffusori in vetro bianco satinato (BI) o ambrarancione satinato (AM). Trasformatore incluso.

Table lamp with double light emission, diffused and concentrated. Structure in anodised satin-finish extruded aluminium (A) or painted matt black (N). Shades in white satin-finish (BI) or amber-orange satin-finish (AM) glass. Transformer included.

Lampe de table à double éclairage, diffus et concentré. Structure en aluminium extrudé anodisé satiné (A) ou verni noir opaque (N). Diffuseurs en verre blanc satiné (BI) ou ambrarancge satiné (AM). Transformateur inclus.

Tischlampe mit diffusem und konzentriertem Licht. Struktur aus stranggepresstem Aluminium, eloxiert, satiniert (A) oder mattschwarz lackiert (N). Glas-Schirme, weiß satiniert (BI) oder bernsteinfarben-orange satiniert (AM). Netzgerät inklusiv.

Lámpara de sobremesa con doble luz, difusa y concentrada. Estructura de aluminio extrudido anodizado satinado (A.) o barnizado negro opaco (N). Difusores de cristal blanco satinado (BI) o ambar-naranja satinado (AM). Transformador incluido.

M5526.. A - N
struttura
V5526.. AM - BI
diffusori

M5526.. A - N
structure
V5526.. AM - BI
shades

M5526.. A - N
structure
V5526.. AM - BI
diffuseurs

M5526.. A - N
Struktur
V5526.. AM - BI
Schirme

M5526.. A - N
estructura
V5526.. AM - BI
difusores

M5526.. A-N + V5526.. BI-AM 44 x 9 x 32

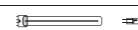

2x18W (FL) G11 +1x20W (FL) GY6.35

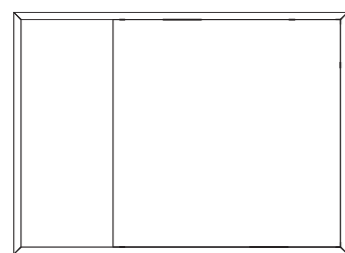

44

9

32



Uovo

Archivio Storico 1972



Minotti, Meda (MI)

Lampada da tavolo.
Montatura in metallo
verniciato bianco. Diffusore
in vetro soffiato bianco
satinato.

Table lamp. White-painted
metal frame. Diffuser in
satin white blown glass.

Lampe de table. Monture
en métal verni blanc.
Diffuseur en verre soufflé
blanc satiné.

Tischlampe. Gestell aus
weißem lackiertem Metall.
Schirm aus weißem,
satinierem Glas.

Lámpara de sobremesa.
Estructura de metal
pintado blanco. Difusor
de cristal soplado blanco
satinado.

2646/0	∅ 18 x 28		1x40W (IN) o/or 1x12W (FL) E27
2646/1*	∅ 27 x 44		1x75W (IN) o/or 1x70W (HA) (ES) E27
2646*	∅ 43 x 62		1x100W (HA) (ES) E27

Classe II IP20 * dimmer

2646/0

2646/1

2646

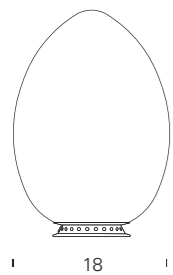

28

18

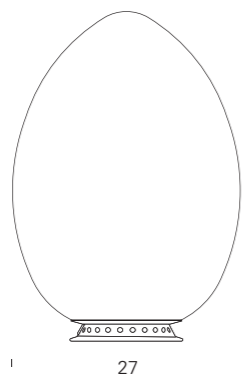

44

27

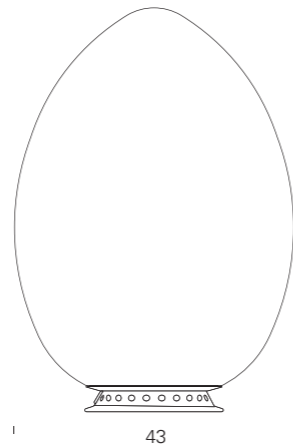

62

43

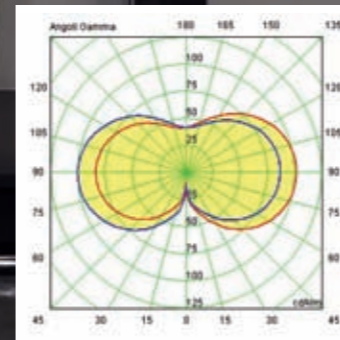

2646/0

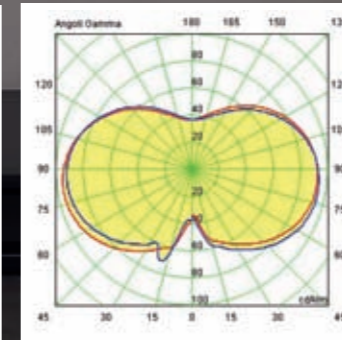

2646/1

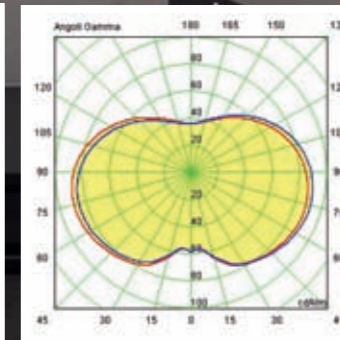

2646

2198

Archivio Storico 1954



Federlegno, Milano

Lampada da terra con dimmer. Base in alluminio satinato. Stelo in legno di pero. Diffusore in vetro soffiato bianco opalino satinato. A richiesta diffusore in polietilene per ordini speciali.

Floor lamp with dimmer. Satin aluminium base. Stem in pear wood. Diffuser in satin white opal blown glass. Upon request diffuser in polyethylene for special orders.

Lampadaire avec dimmer. Base en aluminium satiné. Tige en bois de poirier. Diffuseur en verre soufflé blanc opalin satiné. Sur demande diffuseur en polyéthylène pour commandes spéciales.

Stehleuchte mit Dimmer. Sockel aus satiniertem Aluminium. Stiel aus Birnbaumholz. Schirm aus opalenem, weißem mundgeblasenem Satinglas. Auf Nachfrage Schirm aus Polyäthylen für Sonderbestellungen.

Lámpara de suelo con dimmer. Base de aluminio satinado. Varilla de madera de peral. Difusor de cristal soplado blanco opalino satinado. A petición difusor de polietileno para pedidos especiales.

2198	ø 47 x 180		4x60W (IN) o/or 4x20W (FL) + 1x100W (HA) (ES) E27
2198/1	ø 32 x 150		1x150W (HA) (ES) o/or 1x20W (FL) E27

2198/1 special version

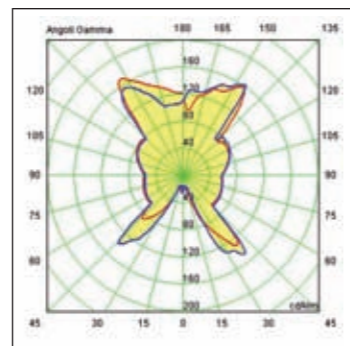
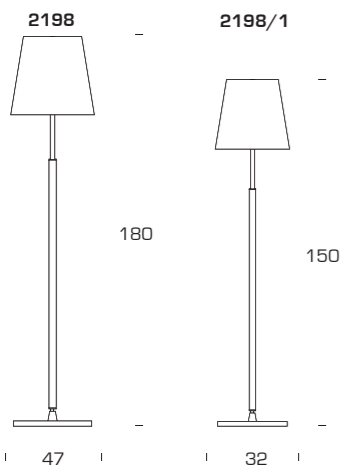

2198

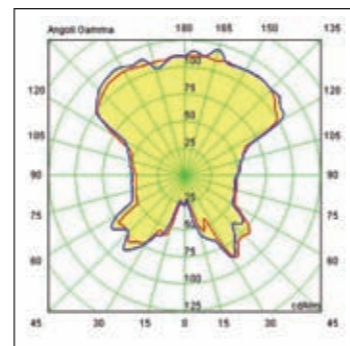

2198/1

3247

Archivio Storico 1954



Curtis / Mallet-Prevost / Coit & Mosle Iip, Milano



Lampada da terra con dimmer. Diffusore in vetro incamiciato multistrato, interno bianco esterno bianco, oppure rosso satinato. Montatura in metallo nichelato. A richiesta diffusore in polietilene per ordini speciali.

Floor lamp with dimmer. Diffuser made of glass "incamiciato", multilayers, internally white, externally white or red satin. Nickel-plated metal frame. Upon request diffuser in polyethylene for special orders.

Lampadaire avec dimmer. Diffuseur en verre gainé multicouches, blanc intérieur, blanc ou rouge opalin satiné extérieur. Monture en métal nickelé. Sur demande diffuseur en polyéthylène pour commandes spéciales.

Stehleuchte mit Dimmer. Schirm aus mehrschichtigem Glas, innen weiß, außen weiß oder rot. Gestell aus vernickeltem Metall. Auf Nachfrage Schirm aus Polyäthylene für Sonderbestellungen.

Lámpara de suelo con dimmer. Difusor de cristal encamisado multistrato, interior blanco, blanco o rojo satinado exterior. Estructura de metal niquelado. A petición difusor de polietileno para pedidos especiales.

3247 - 3247R	∅ 47 x 180		4x60W (IN) o/or 4x20W (FL) + 1x100W (HA) (ES) E27
3247/1 - 3247/1/R	∅ 32 x 150		1x150W (HA) (ES) o/or 1x20W (FL) E27

IP20 3247/1 - 3247/1/R special version

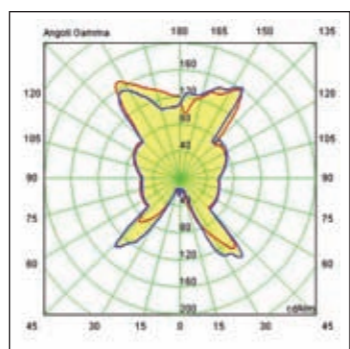
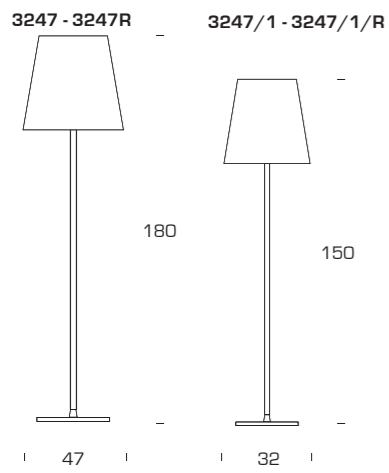

3247 - 3247R

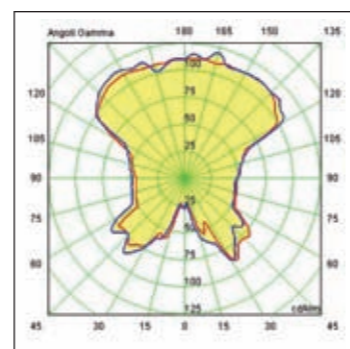

3247/1 - 3247/1/R

Adubai

Matteo Nunziati 2009



Lampada da terra. Vetri temperati bianchi opalini. Base in acciaio inox spazzolato. Doppia emissione luminosa: superiore alogena dimmerabile e inferiore a Led bianchi (temperatura di colore 3.000 K) oppure colorati. Questi ultimi sono forniti come accessori nei colori blu (BL), rosso (R) e verde (V). Accensione separata. A richiesta versione RGB con centralina di comando e telecomando per gestire automaticamente o manualmente le combinazioni di colore.

Floor lamp. White opal tempered glass. Base in brushed stainless steel. Double light emission: dimmable halogen for indirect light emission upwards and Led for diffused ambient lighting, white colour (colour temperature 3.000K). As an alternative Led in red (R), blue (BL) or green (V) colour are available as accessories. Separate switch. Upon request is available the RGB version supplied with control unit and remote control ensuring automatic or manual control of light scenes.

Lampadaire. Base et disques de support en acier inox brossé. Verres trempés blancs opalins. Double source lumineuse: halogène pour un éclairage direct et à Led blanches (température de couleur 3.000 K) pour un éclairage diffus du milieu. Les sources à LED peuvent être colorées rouges (R), bleues (BL) ou vertes (V). Allumage séparé. À la demande, version RGB avec centrale de commande et télécommande pour contrôler automatiquement ou manuellement les ambiances lumineuses.

Stehleuchte. Weißes opalines Hartglas. Basis aus Gratté Edelstahl. Doppelte Lichtquelle: obere Halogenlichtquelle mit Dimmer, untere Lichtquelle mit weißen Leds (Farbtemperatur 3.000 K). Die Led werden auch als Accessoires in den Farben blau (BL), rot (R) und grün (V) mitgeliefert. Getrennte Einschaltung. Auf Anfrage in der Version RGB mit Steuerzentrale und Fernsteuerung, um automatisch oder manuell die Farbkombinationen wählen zu können.

Lámpara de suelo. Base y discos de soporte de acero inoxidable cepillado. Vidrios templados blancos opalinos. Doble fuente luminosa: halógena indirecta y de Led blancos (temperatura de color 3.000 K) para una iluminación difundida de ambiente. Las fuentes de LED pueden ser también de colores rojos (R), azules (BL) o verdes (V). Encendido separado. A petición la version RGB con junto a la centralita de mando y al control remoto para realizar un control automático o manual de las escenas luminosas.

4072BI	∅ 27,5 x 200	☐ ○	1x205W (HA) (ES) E27 + 2x9W (Led)
4073BI	∅ 27,5 x 200	☐ ○	1x205W (HA) (ES) E27 + 2x9W (Led) RGB
L9/40..	BIW - BL - R - V	○	9W (Led)

CE IP20

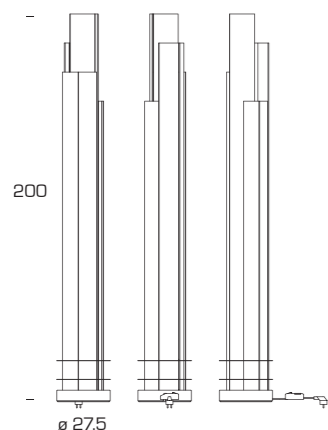

Amax

Charles Williams 2008





Lampada da terra con dimmer. Montatura in metallo cromato. Diffusore in polietilene colore bianco. Cavo di alimentazione, dimmer e spina trasparenti.

Floor lamp with dimmer. Mounting in chrome-plated metal. Diffuser in polyethylene white colour. Transparent electric cable, dimmer and plug.

Lampadaire avec dimmer. Monture en métal chromé. Diffuseur en polyéthylène blanc. Câble d'alimentation, dimmer et prise transparents.

Stehleuchte mit Dimmer. Gestell aus verchromtem Metall. Streukörper aus weißem Polyäthylen. Transparente Netzkabel, Dimmer und Stecker.

Lámpara de suelo con dimmer. Estructura en metal cromado. Difusor de polietileno blanco. Cable de alimentación, dimmer y enchufe transparente.

5586/OBI	ø 40 x 202		3x100W (HA) (ES) or 3x20W (FL) E27
5586BI	ø 55 x 238		3x150W (HA) (ES) or 3x30W (FL) E27

   IP20

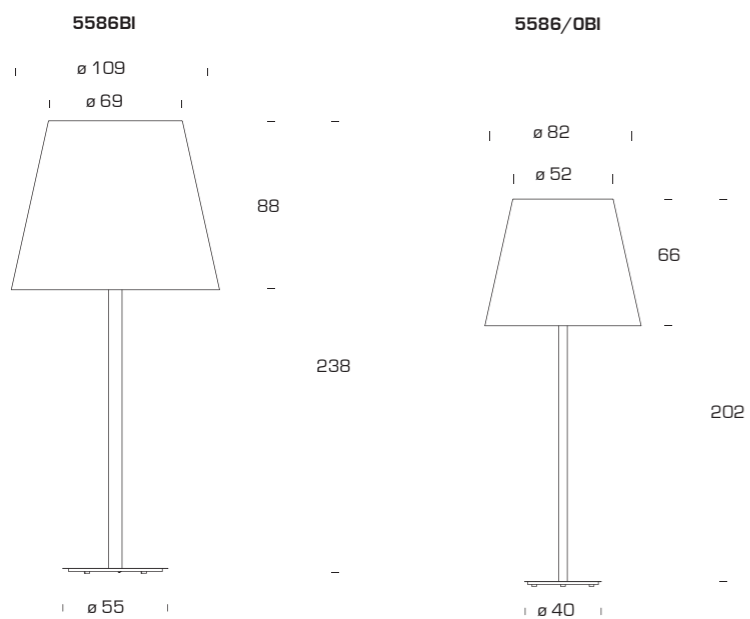

Drum

Franco Raggi 2005



Lampada da terra con dimmer. Diffusore in vetro soffiato bianco acidato. Base in acciaio lucido con stelo in vetro borosilicato trasparente. Cavo, dimmer e spina trasparenti.

Floor lamp with dimmer. Diffuser in white frosted blown glass. Polished steel base with transparent borosilicate glass stem. Transparent cord, dimmer and plug.

Lampadaire avec dimmer. Diffuseur en verre soufflé blanc traité avec l'acide. Base en acier poli, tige en verre borosilicate transparent. Câble, dimmer et fiche transparents.

Stehlampe mit Dimmer. Schirm aus mundgeblasenem Ätztglas, weiß. Sockel aus Glanzstahl mit Lampenstiel aus transparentem Borosilikatglas. Transparentes Netzkabel, Dimmer und Netzstecker.

Lámpara de suelo con dimmer. Difusor de cristal soplado blanco al ácido. Base de acero brillante con barra de soporte de vidrio borosilicato transparente. Cable, dimmer y enchufe transparente.

3681 48 x 48 x 175 1x205W (HA) (ES) E27

CE IP20

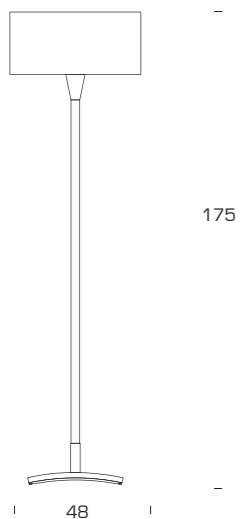

Falena

Alvaro Siza 1994



Lampada da terra a bassa tensione, con trasformatore elettronico e dimmer posizionato sul cavo. Corpo in metallo cromato. Alette diffusori, orientabili, in alluminio anodizzato. Stelo in ottone cromato con base in vetro trasparente molato. Il collegamento elettrico fra lo stelo e il corpo avviene tramite jack.

Low voltage floor lamp with electronic plug-type transformer and dimmer on the cable. Adjustable body in chrome-plated metal. Revolving diffuser wings in anodized aluminium. Thick polished glass base. Stem in chromed brass. A jack allows the electric connection between the base and the body.

Lampadaire à basse tension, avec transformateur électronique à prise et avec interrupteur à double intensité sur le câble. Corps orientable en métal chromé. Diffuseurs à ailettes orientables, en aluminium anodisé. Base en verre biseauté. La connexion électrique entre la base et le corps est assurée par le biais d'une douille-jack.

Niederspannungs-Stehlampe mit elektronischem Trafo und Dimmer am Kabel befestigt. Körper aus verchromtem Metall. Orientierbare Flügel Reflektoren aus eloxiertem Aluminium. Stiel aus verchromtem Messing mit Basis aus transparentem, geschliffenem Glas. Elektrische Verbindung zwischen Körper und Stiel durch Anschaltklinke.

Lámpara de suelo de baja tensión con transformador electrónico de clavija e interruptor en el cable para doble intensidad. Cuerpo orientable de metal cromado. Aletas difusoras orientables de aluminio anodizado. Tija de latón cromado con base de cristal transparente. La conexión entre la tija y el cuerpo se produce mediante jack.

3016
corpo
3018
base e stelo

3016
body
3018
base and stem

3016
corps
3018
base et tige

3016
Körper
3018
Basis und Stiel

3016
cuerpo
3018
base y pie

3016 + 3018 ø 25 x 40 x 120 ⇒ 1x50W (HA) o/or 1x35W (HA) (ES) GY6.35

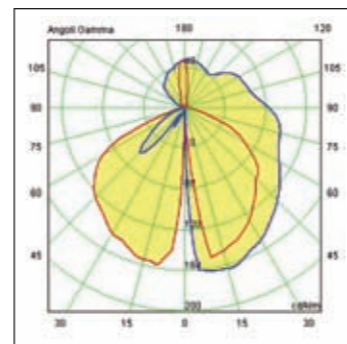
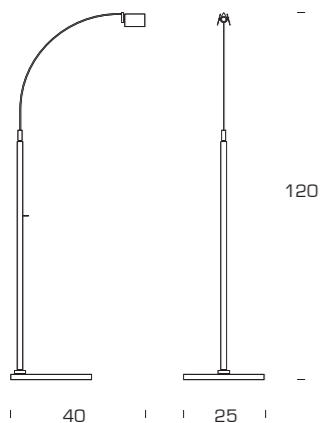

3920

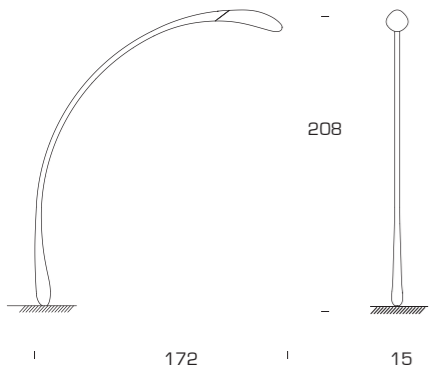

3921

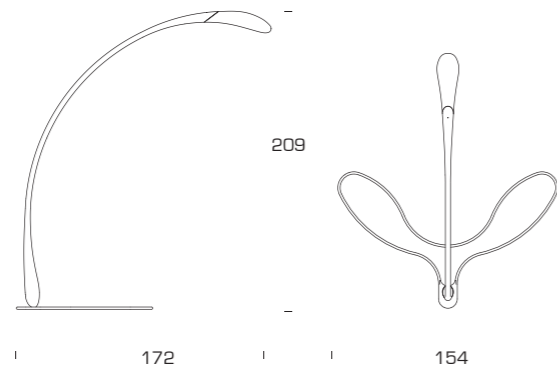

3922

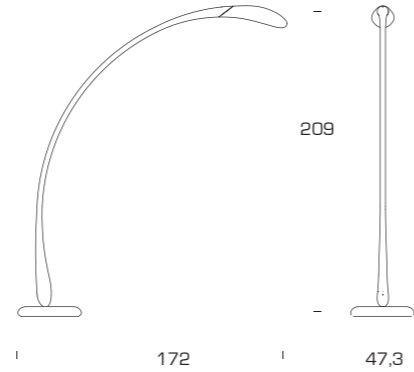

Lampada da terra. Stelo in alluminio lucido realizzato con tecnologia "idroformatura". Diffusore in vetro soffiato bianco lucido. Disponibile in tre versioni: con ancoraggio a pavimento (3920), con base in tubolare metallico curvato (3921) e con zavorra in cemento naturale sabbiato (3922).

Floor lamp. Stem in polished aluminium manufactured with the "hydroforming" technology. Diffuser in polished white blown glass. Available to be installed into the ground (3920), with base in bent metal pipe (3921) and with ballast in sandblasted natural concrete (3922).

Lampadaire. Tige en aluminium brillant réalisé grâce à la technologie de l'hydroforme. Diffuseur en verre soufflé blanc brillant. Disponible avec encrage direct au sol (3920), et avec base en métal tubulaire plié (3921) et avec ballast en ciment naturel sablé (3922).

Stehlampe. Stab aus Aluminium, durch Hydrobuilding Technologie hergestellt. Schirm aus geblasenem poliertem weißem Glas. Erhältlich in der Erde zum verankern (3920), mit einer Platte aus röhrenförmigem gebiegt Metall (3921) und basis aus natürlichem sandgestrahltem Zement (3922).

Lámpara de suelo. Pie de aluminio brillante hecho con tecnología hidrovaciado. Difusor de cristal soplado blanco brillante. Disponible para enterrar (3920), con base de metal tubular metalico curvado (3921) y con base de cemento natural arenado (3922).

3920 - 3921 - 3922 172 x 209 1x150W (HA) E27

CE Class II IP20



Flûte - Magnum

Franco Raggi 1999







Lampada da terra con dimmer. Stelo in vetro borosilicato trasparente. Riflettore in alluminio cromato lucido. Base e supporto riflettore in metallo cromato. Cavo di alimentazione trasparente. Il cono di vetro accoglie al suo interno il riflettore sorretto da tre bracci cromati. La luce si riflette all'interno del cono e si diffonde in modo uniforme verso l'alto.

Floor lamp with dimmer. Borosilicate transparent glass stem. Reflector in chrome-plated polished aluminium. Base and reflector support in chrome-plated metal. Transparent feeding cable. The cone houses a reflector hold by three chrome-plated arms. The light reflects into the cone, thus giving a uniform light emission upwards.

Lampadaire dimmerable. Tige en verre borosilicate transparent. Réflecteur en aluminium chromé poli. Base et support du réflecteur en métal chromé. Câble d'alimentation transparent. Le cône de verre recueille en son intérieur le réflecteur soutenu par trois bras chromés. La lumière se reflète à l'intérieur du cône et se diffuse de manière uniforme vers le haut.

Stehlampe mit Dimmer. Sockel aus transparentem Borosilikat-Glas. Reflektor aus verchromtem glänzendem Aluminium. Basis und Reflektorstütze aus verchromtem Metal. Transparentes Netzkabel. Drei schmale horizontale Stäbe halten einen Kegel fest, der in seinem innerem die Fassung hat. Der Kegel reflektiert das Licht und dank des Glasstreukörper, der den Lichtstrahl nach oben orientiert, erhält man eine gleichmäßige Lichtverteilung innerhalb des Raumes.

Lámpara de suelo con dimmer. Base de vidrio al borosilicato transparente. Reflector de aluminio cromado pulido. Base y soporte reflector de metal cromado. Cable de alimentación transparente. La luz es reflejada dentro el cono y agradece al difuser que dirige la luz hacia arriba una emisión uniforme y difundida ligera.

3300	∅ 27 x 192		1x205W (HA)  E27
3300/1	∅ 32 x 210		1x400W (HA)  R7s/115

       IP20 3300 

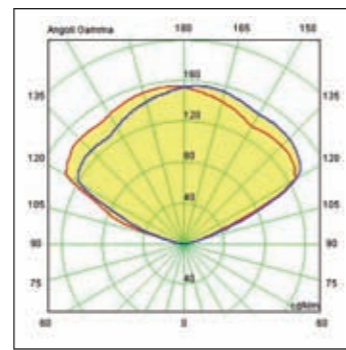
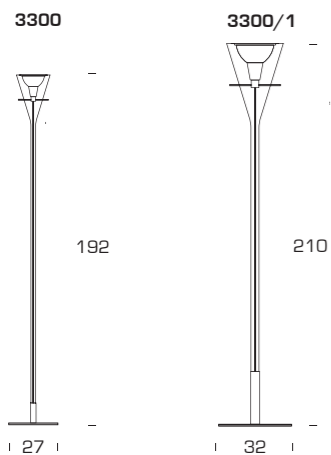

3300

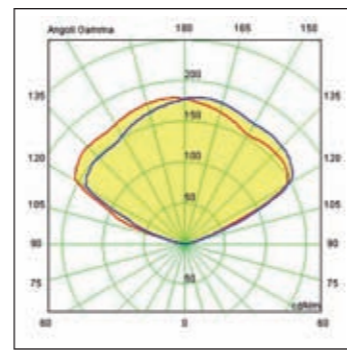

3300/1



Hashira

Metis 2003



Lampada da terra con dimmer. Montatura in acciaio verniciato bianco. Base in acciaio inox. Diffusori in vetro sabbiato a forte spessore.

Floor lamp with dimmer. Structure in white painted steel. Stainless steel base. Diffusers in thick sandblasted glass.

Lampadaire avec dimmer. Structure en acier verni blanc. Base en acier inox. Diffuseurs en verre sablé de forte épaisseur.

Stehlampe mit Dimmer. Struktur aus weißem lackiertem Stahl. Fuß aus Edelstahl. Schirme aus besonders starkem, sandgestrahltem Glas.

Lámpara de suelo con dimmer. Estructura de acero pintado blanco. Base de acero inox. Difusores de cristal arenado muy grueso.

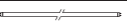

3549 47 x 35 x 200   4x75W GU5.3 (HA) + 4x58W (FL)G13

  IP20

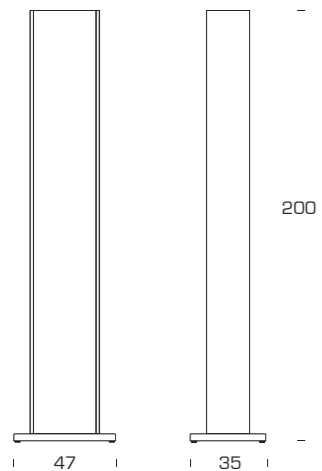

VQ Radisson SAS Residence, Dubai Marina - U.A.E.

Lumen

Archivio Storico 1954



Poliform, Salone del Mobile, Milano



Lampada da terra con doppia dimmerazione. Montatura in metallo verniciato bianco. Diffusore in vetro soffiato bianco opalino satinato.

Floor lamp with double dimmer. White-painted metal frame. Diffuser in white, satin, opal blown glass.

Lampadaire avec double dimmèrisation. Monture en métal verni blanc. Diffuseur en verre soufflé blanc opalin satiné.

Stehlampe mit doppeltem Dimmerfunktion. Gestell aus weißem lackiertem Metall. Schirm aus weißem mundgeblasenem opalenem Satinglas.

Lámpara de suelo con doble dimerización. Estructura de metal pintado blanco. Difusor de cristal soplado blanco opalino satinado.

2482 ø 47 x 178 4x60W (IN) o/or 4x20W (FL) + 1x100W (HA) ES E27

IP20

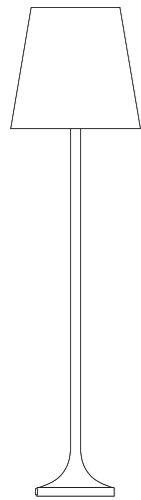

47

178

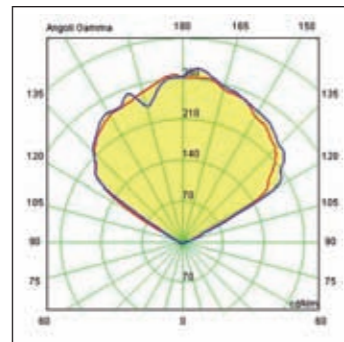

Parabola / parabola

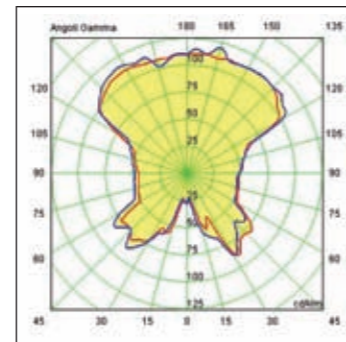

Parabola + paralume / parabola + shade

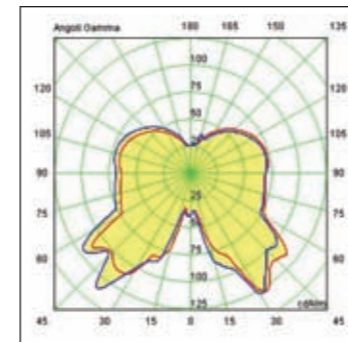

Paralume / shade

Luminator

Pietro Chiesa 1933



Lampada da terra con dimmer. Emissione di luce indiretta. Struttura in ottone nichelato [ON] o verniciata colore nero [N].

Floor lamp with dimmer. Indirect light emission. Structure in nickel-plated brass [ON] or painted black [N].

Lampadaire avec dimmer. Émission de lumière indirecte. Structure en laiton nichelé [ON] ou verni noir [N].

Stehlampe mit Dimmer. Indirekte Lichtverteilung. Stiel aus vernickeltem Messing [ON] oder schwarz lackiert [N].

Lámpara de pie con dimmer. Emisión de luz indirecta. Estructura de latón niquelado [ON] o negro pintado [N].



0556.. N - ON ø 31 x 190 1x230W (HA)  R7s/115

  IP20

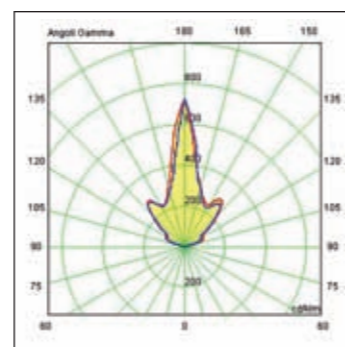
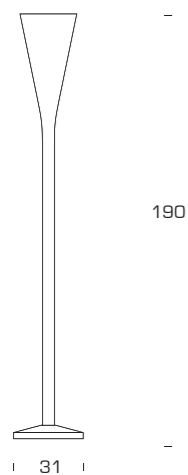

Elektra di Ernestomeda design Pietro Arosio

Naska 1, 2 - Nasketta

1933

Naska 1
8000.. - 8010.. + 8105..

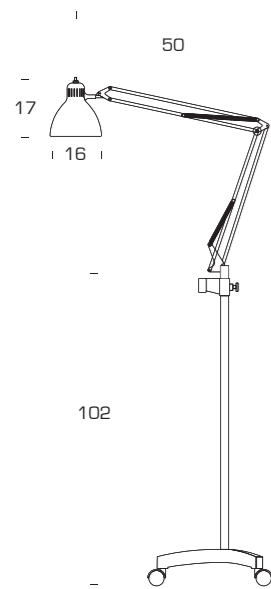

Naska 2
8001.. - 8011.. + 8105..

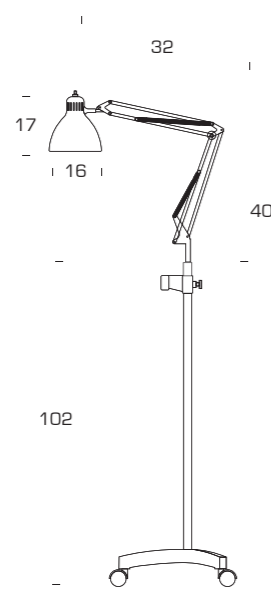

Nasketta
8004 .. + 8105..

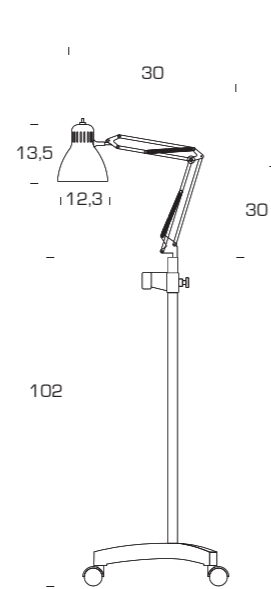

Lampada da terra con braccio orientabile in tutte le direzioni. Base e stelo in acciaio, parabola in alluminio. Base e parabola verniciate nei colori alluminio (A), bianco (BI) o nero opaco (NO). Disponibile anche nella versione Led.

Floor lamp with revolving bracket in all directions. Base and stem in steel, parabola in aluminium. Base and parabola painted in aluminium (A), white (BI) or opal black (NO). Available in the Led version too.

Lampadaire avec bras orientable dans toutes les directions. Base et tige en acier, parabole en aluminium. Base et parabole vernis en aluminium (A), blanc (BI), ou noir opaline (NO). Disponible aussi à la version Led.

Stehleuchte mit in allen Richtungen orientierbarem Arm. Verfügbar. Sockel und Stiel sind aus Stahl, die Parabel ist aus Aluminium. Sockel und Parabel sind aluminiumfarben (A), weiß, (BI) oder opal schwarz (NO) lackiert. Verfügbar auch die Version mit Led.

Lámpara de suelo con brazo orientable en todas las direcciones. Base y varilla de acero, parabola de aluminio. Base y parabola pintadas en color aluminio (A), blanco (BI) o negro opaco (NO). Disponible también la versión con Led.

8105.. A - BI - NO
base terra e stelo

8105.. A - BI - NO
floor base end stem

8105.. A - BI - NO
base lampadaire et tige

8105.. A - BI - NO
Bodenbasis und Stiel

8105.. A - BI - NO
base suelo y pie

8000..	corpo / body / corps / Körper / cuerpo	☞ ☞	1x60W (IN) o/or 1x42W (HA) ES E27
8001..	corpo / body / corps / Körper / cuerpo	☞ ☞	1x60W (IN) o/or 1x42W (HA) ES E27
8004..	corpo / body / corps / Körper / cuerpo	☞ ☞	1x40W (IN) o/or 1x28W (HA) ES E27
8010.* A - BI - CR - NO	corpo / body / corps / Körper / cuerpo	○	3x3W 700mA (Led)
8011.* A - BI - CR - NO	corpo / body / corps / Körper / cuerpo	○	3x3W 700mA (Led)

Classe # IP20 8000.. - 8001.. - 8004 * temperatura di colore / colour temperature / température de couleur / Farbtemperatur / temperatura de color 3000°K alimentatore incluso / ballast included / alimentateur inclus / Vorschaltgerät inbegriffen / alimentador incluido

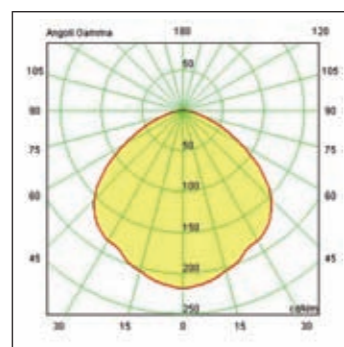

8000.. + 8105..

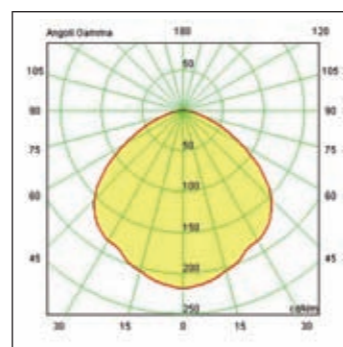

8001.. + 8105..

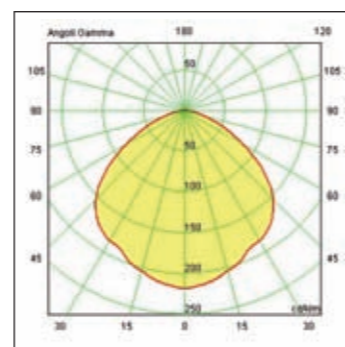

8004 .. + 8105..



Nobi

Metis 1992



Banca Fideuram, Milano

Lampada da terra. Montatura in metallo cromato (CR), verniciato grigio (G) o nichelato satinato (NS). Fornita di diffusori in vetro stampato, acidato o sabbiato, e temperato e di un riflettore in alluminio.

Floor lamp. Chrome-plated (CR), grey painted (G) or satin nickel-plated (NS) metal frame. Provided with pressed, acid-etched or sandblasted and tempered glass diffusers and a reflector in aluminium.

Lampadaire. Monture en métal chromé (CR), verni gris (G) ou nickelé satiné (NS). Equipé de diffuseurs en verre pressé, traité avec l'acide ou sablé, et trempé, et d'un réflecteur en aluminium.

Stehlampe. Gestell aus verchromtem (CR), grauem lackiertem (G) oder satiniert vernickeltem (NS) Metall. Mit Schirme aus gepreßtem geätztem oder sandgestrahltem Hartglas und ein Reflektor aus Aluminium geliefert.

Lámpara de suelo. Estructura de metal cromado (CR), pintado gris (G) o niquelado satinado (NS). Equipada de difusores de cristal grabado, al ácido o arenado, y templado y un reflector de aluminio.

3026.* CR - G - NS	∅ 20 x 190		1x120W (HA) R7s/80
3392.* CR - G - NS	∅ 30 x 205		1x230W (HA) R7s/115
3392/2.. CR - G - NS	∅ 30 x 205		1x150W (MH) Rx7s

Classe II IP20 Classe II 3392.. Classe II 3026.. * dimmer

3026.. 3392.. - 3392/2

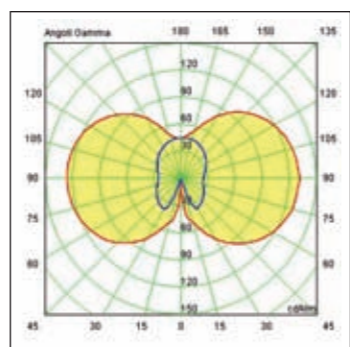
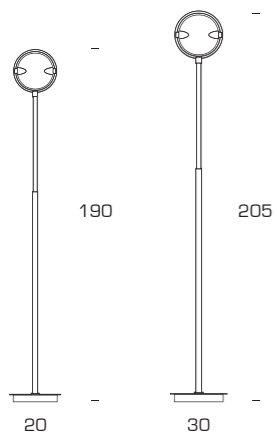

3392..

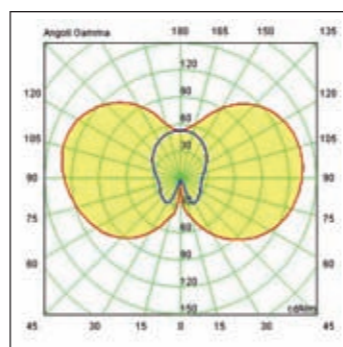

3392/2..

Nobi

Metis 1992



Lampada da terra con doppia dimmerazione. Montatura in metallo cromato (CR), verniciato grigio (G) o nichelato satinato (NS). Diffusori in vetro stampato sabbato e temperato. L'attacco porta-diffusori può essere posizionato in senso orizzontale o verticale.

Floor lamp with double dimmer. Mounting in chrome-plated (CR), grey painted (G) or satin nickel-plated (NS) metal. Diffusers in pressed, sandblasted, tempered glass. The diffuser mount can be positioned either horizontally or vertically.

Lampadaire avec double dimmatisation. Structure en métal chromé (CR), verni gris (G) ou nickelé satiné (NS). Diffuseurs en verre moulé, sablé et trempé. La fixation porte-diffuseurs peut être placée horizontalement ou verticalement.

Stehlampe mit doppelter Dimmerfunktion. Metallstruktur verchromt (CR), grau lackiert (G) oder satiniert vernickelt (NS). Schirm aus bedrucktem und sandgestrahltem Sicherheitsglas. Der Halter des Schirmes kann wahlweise horizontal oder vertikal angeordnet werden.

Lámpara de suelo con doble dimerización. Estructura de metal cromado (CR), pintado gris (G) o niquelado satinado (NS). Difusores de cristal arenado, grabado y templado. El enganche portadifusores se puede colocar horizontal o verticalmente.

R3086
riflettore opzionale in alluminio anodizzato

R3086
optional anodized aluminium reflector

R3086
réflecteur optionnel en aluminium anodisé

R3086
optionaler Reflektor aus eloxiertem Aluminium

R3086
reflector de aluminio anodizado opcional

3599.. CR - G - NS ø 36 x 184 (max 200) 4x120W (HA) (ES) R7s/80

CE Class II IP20

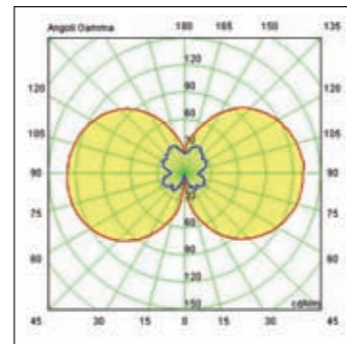
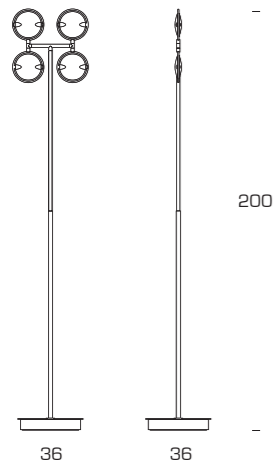

MB, Mici, Barcellona

Nobi

Metis 1992



Lampada da terra con dimmer. Montatura in metallo cromato. Riflettori in alluminio con vetro diffusore satinato. Lo snodo, posizionato sullo stelo, permette un'inclinazione fino a 90° e una rotazione di 360° sul piano orizzontale. Gli schermi sono orientabili e consentono di direzionare la luce.

Floor lamp with dimmer. Chrome-plated metal frame. Aluminium reflectors with satin glass diffusor. The joint positioned on the stem allows an inclination of the lamp up to 90° with 360° rotation on the horizontal plan. The screens can be orientated and allow the light emission to be directed.

Lampadaire avec dimmer. Monture en métal chromé. Réflecteurs en aluminium avec verre diffuseur satiné. L'articulation, positionnée sur la tige permet de l'incliner jusqu'à 90° et de la faire tourner jusqu'à 360° sur le plan horizontal. Les écrans sont orientables ce qui permet de donner à la lumière la direction voulue.

Stehlampe mit Dimmer. Metallstruktur verchromt. Reflektor aus Aluminium mit satiniertem Glasschirm. Neigung um 90° und Drehung um 360° auf der horizontalen Ebene durch Gelenk im Lampenstiel. Lichtstrahl durch verstellbare Blenden ausrichtbar.

Lámpara de suelo con dimmer. Estructura de metal cromado. Reflector de aluminio con cristal difusor satinado. Articulación, situada en el pie, permite una inclinación de hasta 90° y una rotación de 360° sobre el plano horizontal. Las pantallas son orientables y permiten dirigir la luz.

3652CR ø 20 x 163 1x48W (HA) (ES) R7s/BO

CE Classe II IP20

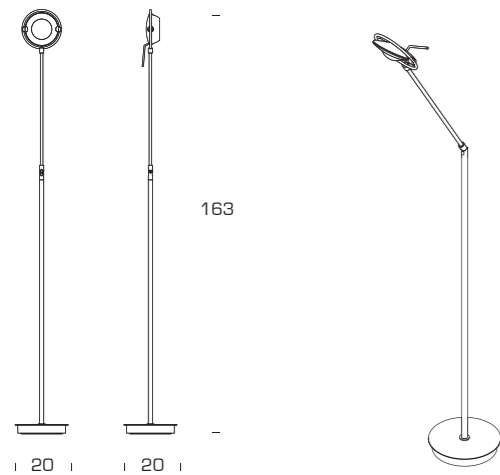

Nuova Segno Tre

Pierluigi Cerri (Gregotti Associati) 1988



Lampada da terra con dimmer. Montatura in metallo verniciato grigio chiaro (GC) o cromato (CR). Conetto diffusore in vetro bianco.

M2688.. CR - GC
montatura
V2686-88BI
conetto

Floor lamp with dimmer. Frame in light grey painted (GC) or chrome-plated (CR) metal. Cone diffuser in white glass.

M2688.. CR - GC
mounting
V2686-88BI
cone

Lampadaire avec dimmer. Monture en métal verni gris clair (GC) ou chromé (CR). Cône diffuseur en verre blanc.

M2688.. CR - GC
monture
V2686-88BI
cône

Stehlampe mit Dimmer. Gestell aus hellgrau lackiertem (GC) oder verchromtem (CR) Metall. Kegel-Schirm aus weißem Glas.

M2688.. CR - GC
Gestell
V2686-88BI
Kegel

Lámpara de suelo con dimmer. Estructura de metal pintado gris claro (GC) o cromado (CR). Cono difusor de cristal blanco.

M2688.. CR - GC
estructura
V2686-88BI
cono

M2688.. CR - GC + V2686-88BI ø 24 x 173



1x205W (HA) (ES) B15d

IP20

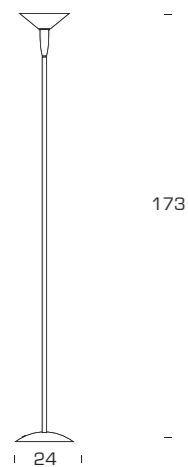

Parola, Parolona

Gae Aulenti / Piero Castiglioni 1980



Lampada da terra con dimmer. Base in vetro trasparente molato. Stelo in vetro borosilicato. Diffusore in vetro soffiato opalino ambrato (AM) o bianco (BI).

Parola
M2659
base e stelo
V2689.. AM - BI
diffusore

Parolona
M2751
base e stelo
V2751.. AM - BI
diffusore

Floor lamp with dimmer. Base in transparent, bevelled glass. Stem in borosilicate glass. Diffuser in amber (AM) or white (BI) opal blown glass.

Parola
M2659
base and stem
V2689.. AM - BI
diffuser

Parolona
M2751
base and stem
V2751.. AM - BI
diffuser

Lampadaire avec dimmer. Base en verre transparent biseauté. Tige en verre borosilicate. Diffuseur en verre soufflé opalin couleur ambre (AM) ou blanc (BI).

Parola
M2659
base et tige
V2689.. AM - BI
diffuseur

Parolona
M2751
base et tige
V2751.. AM - BI
diffuseur

Stehlampe mit Dimmer. Sockel aus geschliffenem, transparentem Glas. Stiel aus Borosilikatglas. Schirm aus opalenem Glas; Farben: bernstein (AM) oder weiß (BI).

Parola
M2659
Basis und Stiel
V2689.. AM - BI
Schirm

Parolona
M2751
Basis und Stiel
V2751.. AM - BI
Schirm

Lámpara de suelo con dimmer. Base de cristal transparente desbastado. Pie de vidrio borosilicato. Difusor de cristal soplado opalino ámbar (AM) o blanco (BI).

Parola
M2659
base y pie
V2689.. AM - BI
difusor

Parolona
M2751
base y pie
V2751.. AM - BI
difusor

M2659 + V2689.. AM - BI ø 24 x 155 1x205W (HA) (ES) B15d

M2751 + V2751.. AM - BI ø 34 x 206 1x205W (HA) (ES) B15d

IP20

M2659 + V2689..

M2751 + V2751..

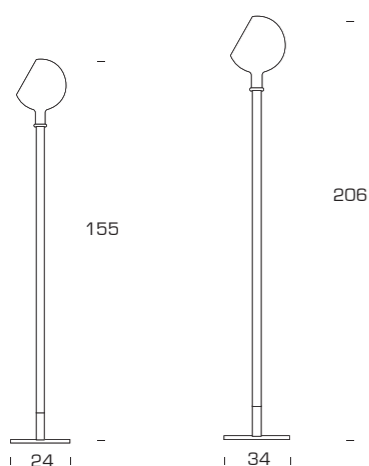

Passion

Studio Beretta 2004





Lampada da terra con dimmer. Montatura in ottone cromato (CR) o nichelato spazzolato (NC). Diffusore in vetro bianco, soffiato e satinato. Riflettore superiore in metallo coordinato alla montatura.

Floor lamp with dimmer. Chrome-plated (CR) or brushed nickel-plated (NC) brass frame. White satin blown glass diffuser. Metal upper reflector, in the same finishing of the mounting.

Lampadaire avec dimmer. Structure en laiton chromé (CR) ou nickelé brossé (NC). Diffuseur en verre blanc, soufflé et satiné. Réflecteur supérieur en métal, coordonné à la monture.

Stehlampe mit Dimmer. Struktur aus verchromtem (CR) oder vernickeltem Messing (NC). Schirm aus weißem, mundeblasem und satiniertem Glas. Metall Reflektor aus gleicher Verzierung des Gestalls.

Lámpara de suelo con dimmer. Montura de latón cromado (CR) o niquelado cepillado (NC). Difusor de cristal blanco, soplado y satinado. Reflector superior en lo mismo acabado de la montura.

3611.. CR - NC ø 39 x 175 2x100W (HA)   2x100W (HA)  a/or 2x20W (FL) E27

     Classe II IP20

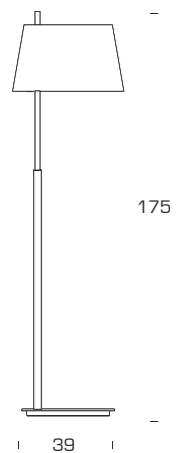

Pirellone

Gio Ponti 1967



Lampada da terra
dimmerabile con doppia
emissione di luce, diffusa
ed indiretta. Montatura in
ottone nichelato satinato.
Diffusori in vetro
stampato e curvato.

Floor lamp with dimmer.
Diffused and indirect
double light emission.
Frame in satin nickel-
plated brass. Diffusers in
pressed and curved glass.

Lampadaire avec dimmer
et double allumage;
lumière diffuse et
indirecte. Monture en
laiton nickelé satiné.
Diffuseurs en verre
pressé et bombé.

Stehlampe mit doppelte
Dimmerfunktion,
ausstrahlender und
indirekter Beleuchtung.
Gestell aus satiniertem,
vernickeltem Messing.
Schirme aus gebogenem
Pressglas.

Lámpara de pie con
dimmer. Emisión de luz
difusa y indirecta.
Estructura de latón
niquelado satinado.
Difusor de cristal
grabado y curvado.

2758 34 x 17 x 184 10x40W [HA] o/or 10x33W [HA] (ES) G9+1x230W [HA] (ES) R7s/115

CE IP20

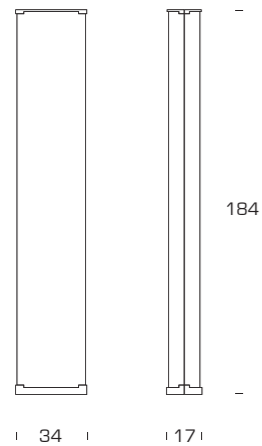

34 17 184



Polaris

Marco Acerbis 2007



Lampada da terra con dimmer. Corpo in nylon verniciato e stampato con tecnologia rotazionale. Base in acciaio satinato. Scocca bianca lucida (BI), nera lucida (N) e ametista lucida (VI).

Floor lamp with dimmer. Varnished nylon structure manufactured with rotation moulding process. Satin steel base. Available in the colours: glossy white (BI), glossy black (N) and glossy amethyst (VI).

Lampadaire avec dimmer. Corps en nylon verni moulé avec technologie rotationnelle. Base en acier satiné. Coque blanche brillante (BI), noir brillante (N) et améthyste brillante (VI).

Stehlampe mit Dimmer. Gestell aus lackiertem Nylon, durch Rotationsspreßung hergestellt. Basis aus satiniertem Stahl. Erhältlich in den Farben: poliert weiß (BI), poliert schwarz (N) und poliert violett (VI).

Lámpara de suelo con dimmer. Cuerpo en nylon pintado obtenido a través de moldeado rotacional. Base en acero satinado. El cuerpo está disponible en los colores blanco brillante (BI), negro brillante (N) y de color ametista brillante (VI).

Modello comunitario depositato

Design patent pending

Modèle communautaire déposé

Eingetragenes Warenzeichen

Modelo comunitario depositado

3829.. BI - N - VI ø 30 x 193 1x230W (HA) (ES) R7s/115

CE IP20

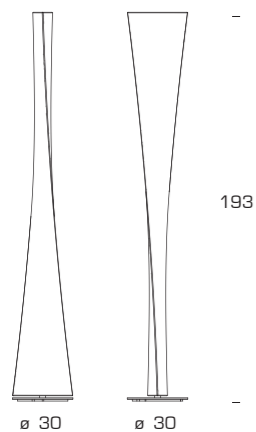

Prima Signora

Daniela Puppa 1992



Lampada da terra con dimmer. Montatura cromata. Diffusore in vetro soffiato opalino bianco.

M2891CR
struttura
V2891BI
diffusore

Floor lamp with dimmer. Chrome-plated mounting. Diffuser in white opal blown glass.

M2891CR
structure
V2891BI
diffuser

Lampadaire avec dimmer. Monture chromée. Diffuseur en verre soufflé opalin couleur blanc.

M2891CR
structure
V2891BI
diffuseur

Stehleuchte mit Dimmer. Verchromtes Gestell. Schirm aus opalenem mundgeblasenem weißem Glas

M2891CR
Gestell
V2891BI
Schirm

Lámpara de suelo con dimmer. Estructura cromada. Difusor de cristal soplado opalino blanco.

M2891CR
estructura
V2891BI
difusor



M2891CR + V2891BI ø 50 x 180 1x205W (HA)  E27

   IP20

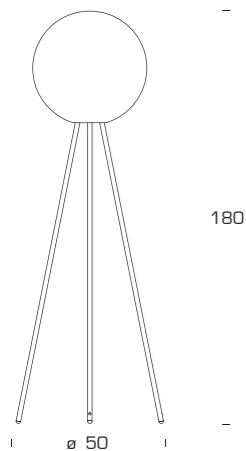

Sara

Pierluigi Cerri (Gregotti Associati) 1933



Lampada da terra.
Montatura in metallo
colore alluminio con
diffusore in policarbonato
colore avorio serigrafato
internamente (A) oppure
montatura in metallo
cromato con diffusore in
policarbonato bianco
ottico (CR/BI). Accen-
sione mediante cordicella.

Floor lamp. Mounting in
grey colour aluminium
with polycarbonate
diffuser in ivory colour,
silkscreened inside (A)
or mounting in chrome-
plated metal with white
optical diffuser in
polycarbonate (CR/BI).
Switch by means of a
string.

Lampadaire. Monture en
métal verni aluminium
avec diffuseur en
polycarbonate couleur
ivoire, sérigraphié
intérieurement (A) ou
monture en métal
chromé avec diffuseur en
polycarbonate couleur
blanc optique (CR/BI).
Allumage avec cordelette.

Stehleuchte. Gestell aus
aluminiumfarbenem
Metall umit Schirm aus
Elfenbeinfarbenem
Polykarbonat, innen
siebgedruckt (A) oder
Gestell aus verchromtem
Metall mit Schirm aus
weißem optischem
Polykarbonat (CR/BI).
Schalter mit Kordel.

Lampara de suelo.
Estructura de metal
pintado color aluminio con
difusor de policarbonato
blanco marfil, serigrafato
en el interior (A) o
estructura de metal
cromado con difusor de
policarbonato blanco
óptico (CR/BI). Encendido
con cuerda.

5154.. A - CR/BI 37 x 24 x 162 1x140W (HA) E27

CE IP20

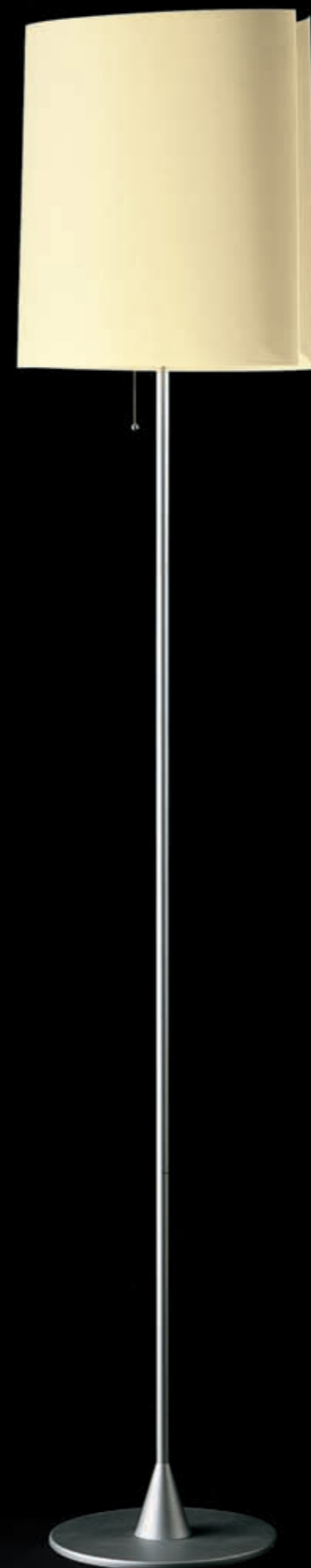
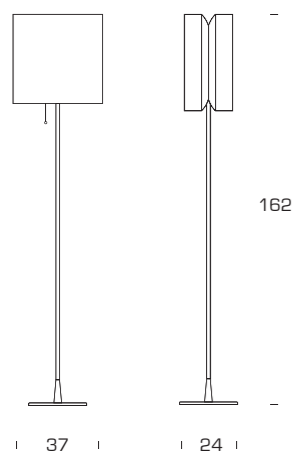

Scintilla Terra

Piero Castiglioni 1983

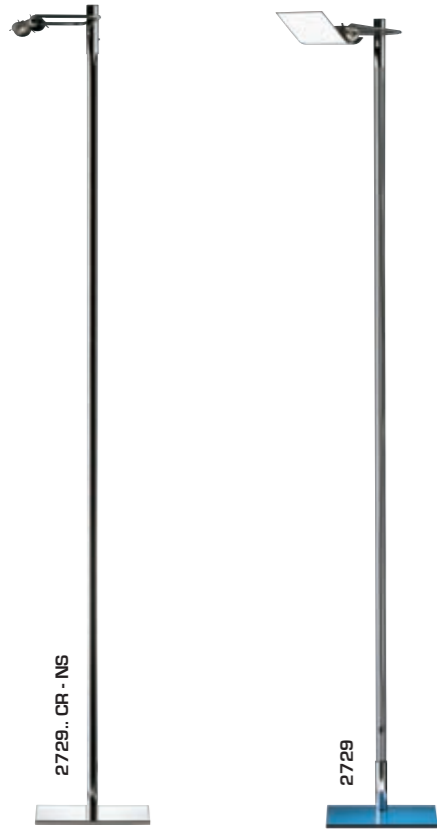

2729

Lampada da terra con dimmer. Base in vetro blu. Stelo in vetro borosilicato. Portalamпада in acciaio cromato. Riflettore in alluminio anodizzato.

2729

Floor lamp with dimmer. Base in blue glass. Stem in borosilicate glass. Chrome steel lamp holder. Anodized aluminium reflector.

2729

Lampadaire avec dimmer. Base en verre bleu. Tige en verre borosilicate. Douille en acier au chrome. Réflecteur en aluminium anodisé.

2729

Stehlampe mit Dimmer. Sockel aus blauem Glas. Stiel aus Borosilikatglas. Lampenfassung aus Chromstahl. Reflektor aus eloxiertem Aluminium.

2729

Lámpara de suelo con dimmer. Base de cristal azul. Pie de vidrio borosilicato. Portabombilla de acero al cromo. Reflector de aluminio anodizado.

2729.. CR - NS

Lampada da terra con dimmer. Struttura in metallo cromato (CR) o nichelato satinato (NS). Portalamпада in acciaio cromato. Riflettore in alluminio anodizzato.

2729.. CR - NS

Floor lamp with dimmer. Structure in chrome-plated (CR) or satin-finish nickel-plated (NS) metal. Chrome steel lamp holder. Anodized aluminium reflector.

2729.. CR - NS

Lampadaire à dimmer. Structure en métal chromé (CR) ou nickelé satiné (NS). Porte-lampe en acier au chrome. Réflecteur en aluminium anodisé.

2729.. CR - NS

Stehlampe mit Dimmer. Metallstruktur, verchromt (CR) oder satiniert (NS) vernickelt. Lampenfassung aus Chromstahl. Reflektor aus eloxiertem Aluminium.

2729.. CR - NS

Lámpara de suelo con dimmer. Estructura en metal cromado (CR) o niquelado satinado (NS). Portalamпада de acero al cromo. Reflector de aluminio anodizado.

2729	24 x 24 x 180		2x230W (HA) (ES) R7s/115
2729.. CR - NS	26 x 26 x 180		2x230W (HA) (ES) R7s/115

IP20

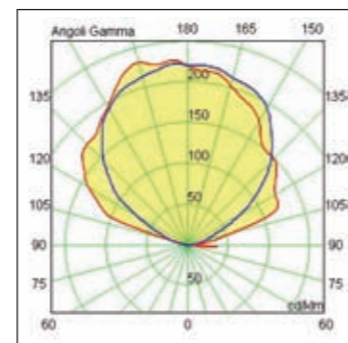
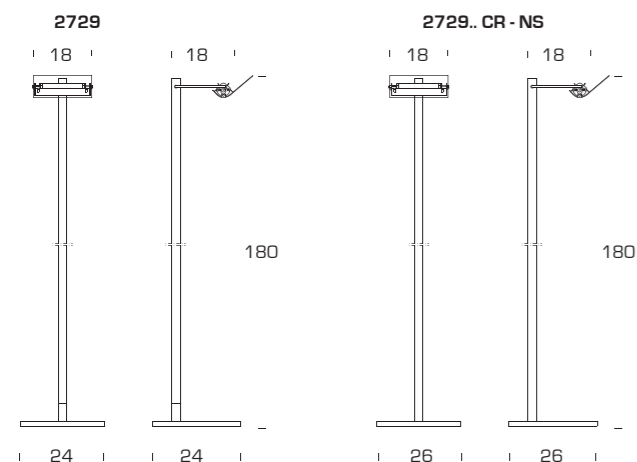

T0024

Gio Ponti 1932



Lampada da terra.
Montatura in metallo
cromato. Dischi in vetro
temperato trasparente.
Diffusore centrale in vetro
termoresistente sabbiato.

Floor lamp. Chrome-plated
metal frame. Disks in
transparent, tempered
glass. Diffuser in
sandblasted, heat-
resistant glass.

Lampadaire. Monture en
métal chromé. Disques en
verre trempé transparent.
Diffuseur central en verre
thermorésistant sablé.

Stehlampe. Gestell aus
verchromtem Metall.
Scheiben aus
transparentem Hartglas.
Zentraler Schirm aus
hitzebeständigem
sandgestrahltem Glas.

Lámpara de suelo.
Estructura de metal
cromado. Discos de
cristal templado
transparente. Difusor
central de cristal
termorresistente
arenado.



T0024VN

∅ 55 x 190



1x205W (HA) E27

CE IP20

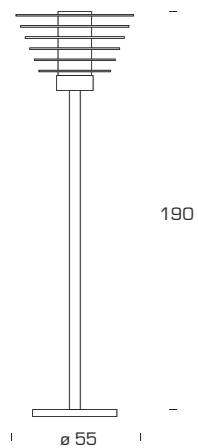

Three Sixty

Foster + Partners 2008



Lampada da terra con dimmer. Struttura in ottone, base e zavorra in zama, parabola in resina. Disponibile verniciata alluminio (A), bianco opaco (BI), cromato (CR) e grigio scuro (GS). Due snodi brevettati collocati nella base e sul braccio consentono alla lampada una rotazione complessiva di 300°. La testa, ruotabile di 360°, permette di orientare il flusso luminoso in tutte le direzioni.

Floor lamp with dimmer. Structure in brass, base and ballast in zamak metal alloy. Parabola in resin. Available painted aluminium (A), matt white (BI), chrome-plated (CR) and dark grey (GS). Two patent pending joints situated in the base and on the arm allow the appliance to be rotated 300°. The head, 360° adjustable, allows the lighting beam to be orientated in all the directions.

Lampadaire avec dimmer. Structure en laiton. Base et lest en zamak. Parabole en résine. Le tout verni dans les couleurs: aluminium (A), blanc mat (BI) ou gris foncé (GS). Deux pivots brevetés, disposés sur la base et sur la tige permettent à la lampe une rotation de 300°. La tête, elle aussi rotatable à 360°, donne la possibilité d'ajuster la diffusion de la lumière dans toutes les directions.

Stehleuchte mit Dimmer. Struktur aus Messing, Basis und Ballast aus Zink-Aluminium-Magnesium-Legierung, Parabel aus Kunstharz. In folgenden Farben lackiert: aluminiumfarben (A), mattweiß (BI), verchromt (CR) und dunkelgrau (GS). Zwei patentierte Gelenke ermöglichen eine 300° Rotation der Leuchte. Dank einem ausrichtbaren Leuchtenkopf kann die Lichtverteilung in alle Richtungen orientiert werden.

Lámpara de suelo con dimmer. Estructura de latón. Base y contrapeso en zamak. Aleación metálica de zinc. Parabola de resina. Acabados: aluminio (A), blanco mate (BI), cromado (CR) o gris oscuro (GS). Dos articulaciones una en la base y una en el brazo admiten una rotación total de la lámpara de 300°. La cabeza, orientable de 360°, admite l'orientación del flujo luminoso en todas direcciones.



5475.. A - BI - CR - GS ø 27 x 90 x 130 1x150W (HA) o/or 1x35W (HA) ES GY6.35

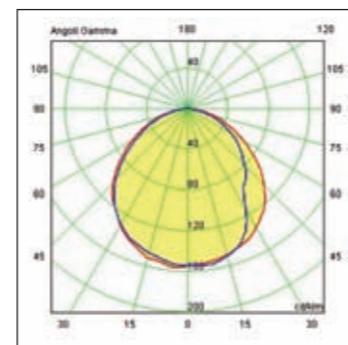
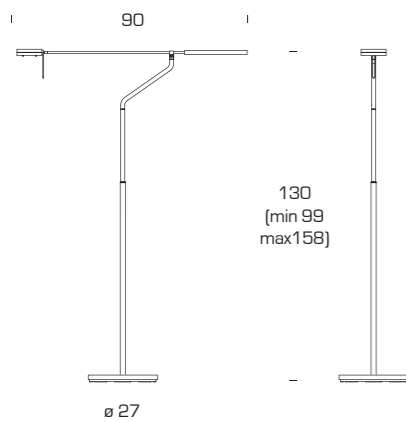

Time 21:30

Studio Parisotto / Formenton 2006

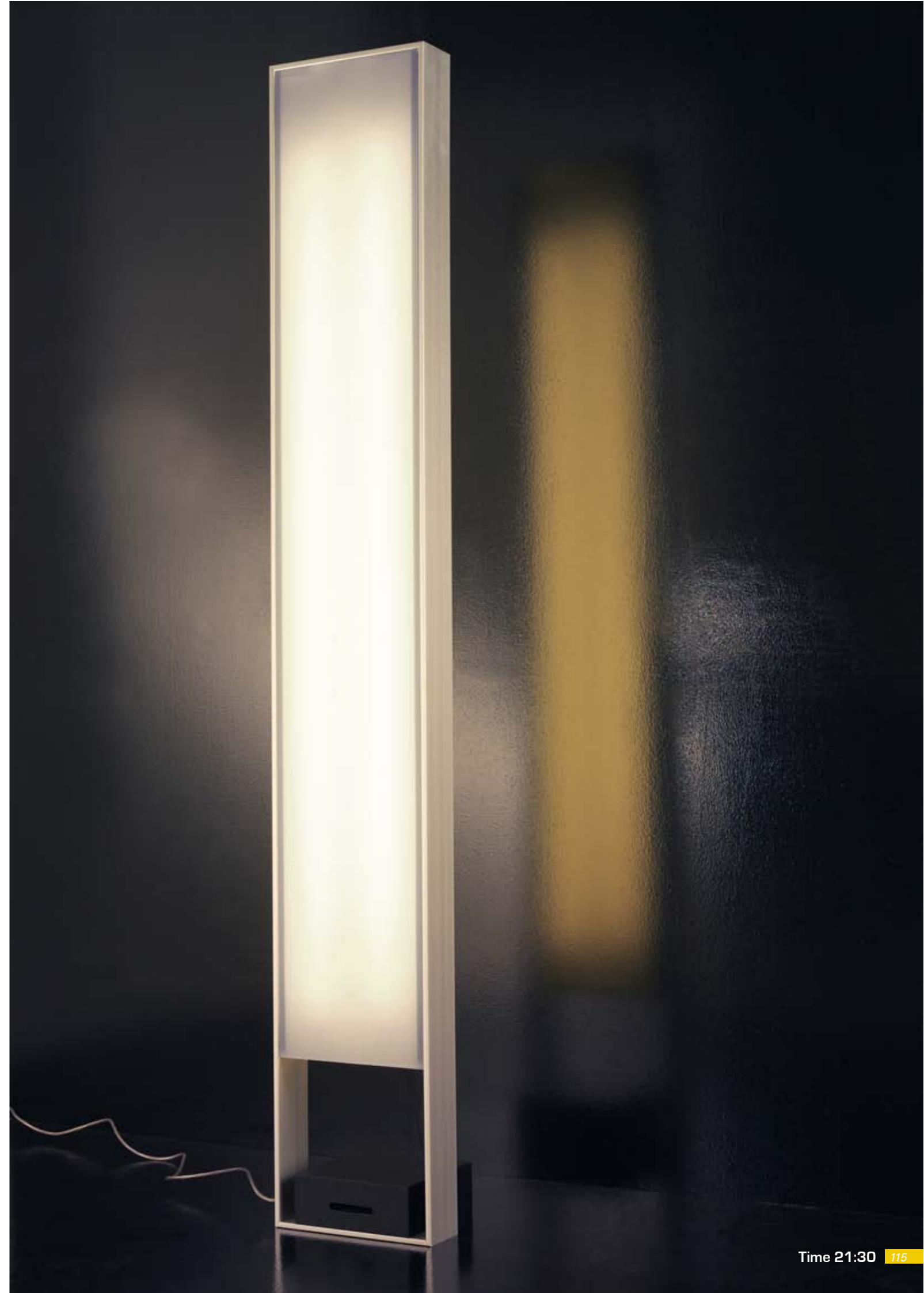

Lampada da terra con dimmer. Doppia fonte luminosa e zavorra amovibile per applicazione verticale o da appoggio a parete. Struttura in alluminio estruso anodizzato satinato [A] o verniciato nero opaco [N]. Diffusori in vetro bianco satinato [BI] o ambra/arancione satinato [AM].

Floor lamp with dimmer. Double light source and removable ballast for vertical application or lean against the wall. Structure in anodised satin-finish extruded aluminium [A] or painted matt black [N]. Shades in white satin-finish [BI] or amber/orange satin-finish [AM] glass.

Lampadaire avec dimmer. Double source lumineuse et lest amovible pour application verticale ou appuyé au mur. Structure en aluminium extrudé anodisé satiné [A] ou verni noir opaque [N]. Diffuseurs en verre blanc satiné [BI] ou ambre/orange satiné [AM].

Stehlampe mit Dimmer. Doppelter Lichtquelle und verstellbarem Gewicht für vertikale Verwendung als Stehlampe oder zur Anlehnung an die Wand. Struktur aus Aluminium, stranggepresst, eloxiert, satiniert [A] oder mattschwarz lackiert [N]. Schirme aus Glas, weiß satiniert [BI] oder bernsteinfarben/orange satiniert [AM].

Lámpara de suelo con dimmer. Doble fuente luminosa y lastre móvil para aplicación vertical o de apoyo o de apoyo en pared. Estructura de aluminio extrudido anodizado satinado [A.] o barnizado negro opaco [N]. Difusores de cristal blanco satinado [BI] o ambar-naranja satinado [AM].

M5527.. A - N
montatura
V5527.. AM - BI
diffusori

M5527.. A - N
mounting
V5527.. AM - BI
shades

M5527.. A - N
monture
V5527.. AM - BI
diffuseurs

M5527.. A - N
Gestell
V5527.. AM - BI
Schirme

M5527.. A - N
montura
V5527.. AM - BI
difusores

M5527.. A - N + V5527.. AM - BI 29 x 21 x 190

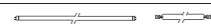

2x35W (FL) G5+1x120W (HA) (ES) R7s/80

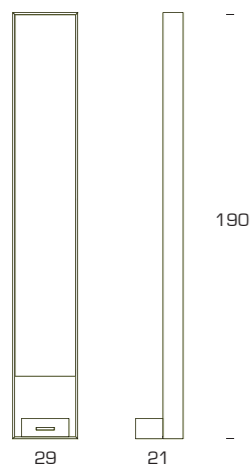

Toobo

Marco Merendi 2007

3843...

Lampada da terra. Corpo e base in alluminio, disponibili bianco testurizzato internamente e esternamente (BI/BI), cromato esternamente e verniciato arancio lucido internamente (CR/AR), cromato esternamente e verniciato bianco lucido internamente (CR/BI). Doppia emissione luminosa, diretta e indiretta. Accensione separata. Il diffusore superiore può essere rimosso per un'emissione luminosa indiretta più diffusa.

3844...

Lampada da lettura con caratteristiche formali e funzionali analoghe alla versione da terra. Il fascio di luce diretta è orientabile mediante un'apposita levetta di rotazione posta dietro l'apparecchio che consente di indirizzare il flusso luminoso nella zona di lettura.

3843...

Floor lamp. Body and base in aluminium, available texturized white inside and outside (BI/BI), chrome-plated outside and polished painted orange inside (CR/AR), chrome-plated outside and polished painted white inside (CR/BI). Double light emission, direct and indirect. Separate switch. The upper diffuser can be removed for a more diffused indirect light emission.

3844...

Reading version with formal and functional features similar to the floor version. The direct light emission can be orientated through a small lever positioned behind the appliance that allows to direct the lighting beam in the reading area.

3843...

Lampadaire. Corps et base en aluminium, disponibles dans les finitions suivantes: blanc texturisé intérieurement et extérieurement (BI/BI), chromé à l'extérieur et orange à l'intérieur (CR/AR) et chromé à l'extérieur et blanc brillant à l'intérieur (CR/BI). Double émission de lumière, directe et indirecte. Allumage séparé. Possibilité d'enlever le diffuseur supérieur pour une illumination indirecte plus douce.

3844...

Lampe de lecture avec caractéristiques formelles et fonctionnelles analogues à la version lampadaire. La lampe est pourvue d'un levier de rotation positionné derrière l'appareil qui permet l'orientation du flux lumineux vers la zone de lecture.

3843...

Stehleuchte. Körper und Basis aus Aluminium, die innen und außen texturisiert (BI/BI), außen verchromt und innen orangefarben (CR/AR), außen verchromt und innen weiß glänzend (CR/BI) erhältlich sind. Doppelte Lichtausstrahlung: direkt und indirekt. Getrennte Einschaltung. Für eine indirekter Beleuchtung kann der obere Schirm entfernt werden.

3844...

Leseleuchte mit ähnlichen formlichen und funktionalen Charakteristiken der Stehleuchte. Die Leuchte verfügt über eine kleine Rotationshebel, der ermöglicht, ein direktes Licht auf den jeweils zu erleuchtenden Bereich zu zielen und die optimale Lichtverteilung auf den Arbeitsbereich gewährleisten.

3843...

Lámpara de suelo. Cuerpo y base de aluminio, disponible blanco texturizado internamente y externamente (BI/BI), cromado externamente y pintado anaranjado pulido internamente (CR/AR), cromado externamente y pintado blanco pulido internamente (CR/BI). Doble emisión luminosa, directa e indirecta. Encendido separado. El difusor superior se puede remover para obtener una emisión de luz indirecta más difusa.

3844...

Lámpara de lectura con características de forma y funcionalidad igual a la versión de suelo. En la versión lectura el haz de luz directa se puede orientar mediante una palanquita situada detrás del aparato que permite dirigir el flujo luminoso hacia la zona de lectura.

3843..BI/BI - CR/AR - CR/BI ø 9,5 x 210 1x205W (HA) (ES)B15d + 1x75W (HA) GU-GZ10

3844..BI/BI - CR/AR - CR/BI ø 9,5 x 210 1x205W (HA) (ES)B15d + 1x50W (HA)GU-GZ10

CE IP20

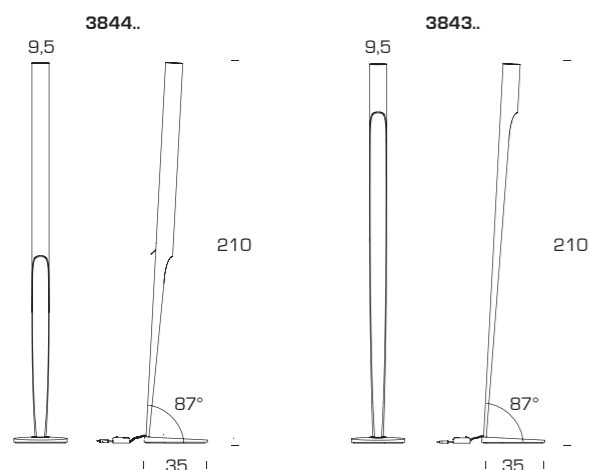

Vertigo

Marco Acerbis 2005



Lampada da terra, a luce indiretta, con dimmer. Struttura in lamiera d'alluminio piegata e lucidata a specchio o anodizzata (A) o verniciata bianco (BI), nero (N). Base in metallo verniciato nero opaco. La struttura può ruotare di 320° sul piano orizzontale.

Floor lamp with dimmer. Indirect light emission. Structure in folded aluminium sheet, mirror finish or anodised (A), white painted (BI) or black painted (N). Base in painted steel, matt black colour. The structure rotates 320° on the horizontal plan.

Lampadaire à lumière indirecte avec dimmer. Structure en tôle d'aluminium pliée et polie miroir ou anodisée (A) ou verni blanc (BI), noir (N). Base en acier verni noir mat. Le corps tourne à 320° sur le plan horizontal.

Stehlampe für indirekte Beleuchtung mit Dimmer. Struktur aus gefaltem Aluminiumblech, blankpoliert oder eloxiert (A) oder weiß (BI) oder schwarz (N) lackiert. Sockel aus Stahl, lackiert, mattschwarz. Der Körper läßt sich auf der horizontalen Ebene um 320° drehen.

Lámpara de suelo, de luz indirecta, con dimmer. Estructura en chapa de aluminio doblada y con brillo a espejo o anodizada (A.) o barnizada en blanco (BI), negro (N). Base de acero barnizado negro opaco. La estructura gira 320° sobre el plano horizontal.





Modello comunitario depositato

Design patent pending

Modèle communautaire déposé

Eingetragenes Warenzeichen

Modelo comunitario depositado

5531.. A - BI - N	∅ 32 x 194		1x230W (HA)  R7s/115
5531	∅ 32 x 194		1x230W (HA)  R7s/115

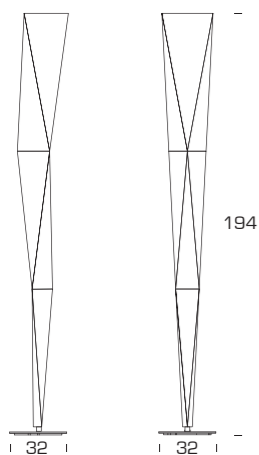

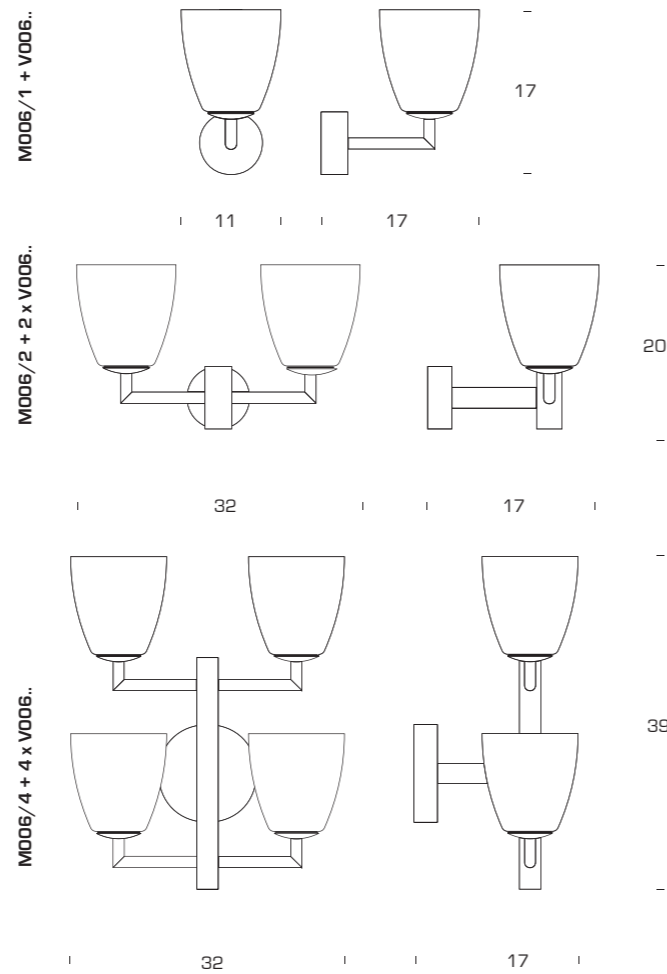

Lampada da parete a 1, 2 o 4 luci. Montatura in metallo cromato. Diffusori in vetro soffiato e satinato bianco (BI), blu (BL), rosso (R), rosa (RS), verde (V). Diffusori disponibili in altri colori per quantitativi superiori a 100 pezzi.

Wall lamp available with 1, 2 or 4 shades. Chrome-plated metal frame. White (BI), blue (BL), red (R), pink (RS), green (V), satin blown glass diffusers. Diffusers available in other colours for quantities more than 100 pieces.

Applique avec 1, 2 ou 4 ampoules. Monture en métal chromé. Diffuseurs en verre soufflé satiné blanc (BI), bleu (BL), rouge (R), rose (RS), vert (V). Diffuseurs en autres couleurs pour commandes au-dessus 100 de pièces.

Wandlampe mit 1, 2 oder 4 Leuchtmitteln. Gestell aus verchromtem Metall. Schirme aus mundgeblasenem Satinglas in weiß (BI), blau (BL), rot (R), rosa (RS), grün (V). Schirme in anderen Farben für Bestellungen höher als 100 Stücke.

Applique de pared de 1, 2 o 4 difusores. Estructura de metal cromado. Difusor de cristal soplado y satinado blanco (BI), azul (BL), rojo (R), rosa (RS), verde (V). Difusores de otros colores para pedidos mayor de 100 piezas.

M006/1 - M006/2 - M006/4
montatura

M006/1 - M006/2 - M006/4
mounting

M006/1 - M006/2 - M006/4
monture

M006/1 - M006/2 - M006/4
Gestell

M006/1 - M006/2 - M006/4
estructura

V006.. BI - BL - R - RS - V
diffusore

V006.. BI - BL - R - RS - V
diffuser

V006.. BI - BL - R - RS - V
diffuseur

V006.. BI - BL - R - RS - V
Schirm

V006.. BI - BL - R - RS - V
difusor

M006/1+V006.. BI - BL - R - RS - V	11 x 17 x 17	☞ ☞	1x60W (IN) o/ or 1x42W (HA) (ES) E14
M006/2+2xV006.. BI - BL - R - RS - V	32 x 17 x 20	☞ ☞	2x60W (IN) o/ or 2x42W (HA) (ES) E14
M006/4+4xV006.. BI - BL - R - RS - V	32 x 17 x 39	☞ ☞	4x60W (IN) o/ or 4x42W (HA) (ES) E14

CE IP20

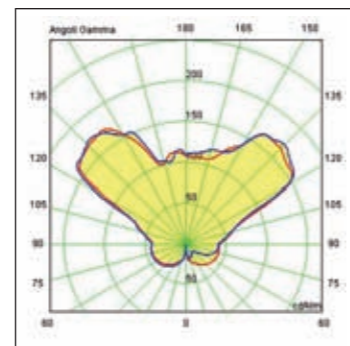

M006/1

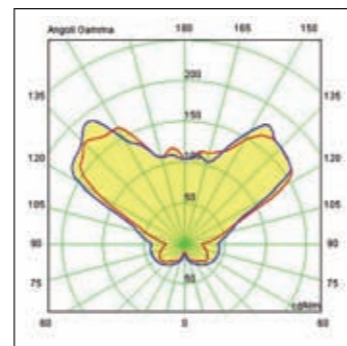

M006/2





Lampada da parete. Snodo e struttura in metallo cromato. Diffusore in metacrilato colore bianco opale con elemento decorativo e organico ottenuto attraverso il supporto in alluminio delle schede Led applicate su una lastra di policarbonato alveolare. Viene fornita con alimentatore da incassare. Emissione luminosa indiretta diffusa e orientabile grazie allo snodo.

Wall lamp. Joint and structure in chrome-plated metal. Diffuser in opal white methacrylate with decorative and organic function obtained through the support in aluminium, housing the Led board mounted on a sheet in alveolar polycarbonate. Provided with ballast to be recessed in. Indirect and diffused light emission adjustable by means of the joint.

Applique pour mur. Articulation et structure en métal chromé. Diffuseur en méthacrylate blanc opale avec élément organique décoratif composé de Led noyées à l'intérieur de feuilles d'aluminium et appliquées sur une plaque en polycarbonate alvéolaire. La lampe est fournie avec un alimentateur à encastrer. Émission de lumière indirecte diffuse et orientable grâce à l'articulation.

Wandleuchte. Gelenk und Struktur aus verchromtem Metall. Streukörper aus opalweißem Metacrylat mit dekorativem und organischem Element, bestehend aus einem Aluminiumhalter für die Led Platinen, die auf einer zellenförmigen Polykarbonat-Platte angebracht sind. Die Lampe wird mit einem Einbauvorschaltgerät geliefert. Indirekte und diffuse Lichtausstrahlung, dank des Gelenks verstellbar.

Lámpara para pared. Articulación y estructura de metal cromado. Difusor de metacrilato color blanco ópalo con elemento decorativo y orgánico obtenido a través del soporte de aluminio de las tarjetas Led aplicadas en una lastra de policarbonato alveolar. Se suministra con alimentador para empotrar. Emisión luminosa indirecta difundida orientable gracias a la articulación.

4025 21,5 x 30 x 11 ○ 15W (Led)

temperatura di colore / colour temperature / température de couleur / Farbtemperatur / temperatura de color 6000°K

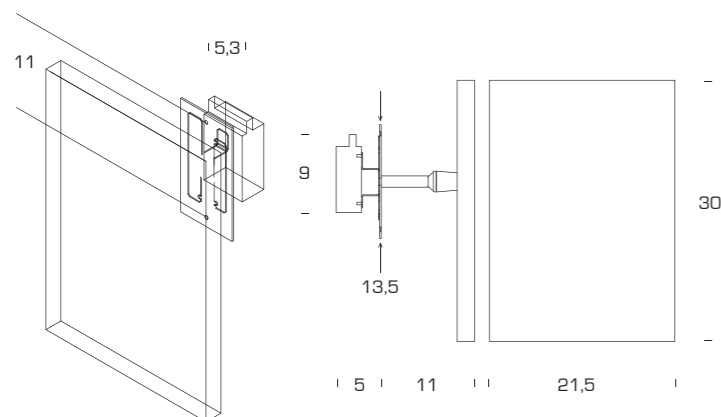

Ananas

Vico Magistretti 1999

M3302 - M3303 - M3304 + V3290..

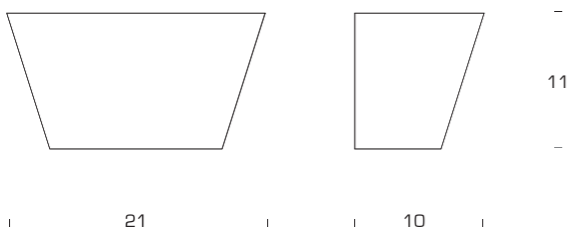

M3302/1 - M3303/1 - M3304/1 + V3290/1..

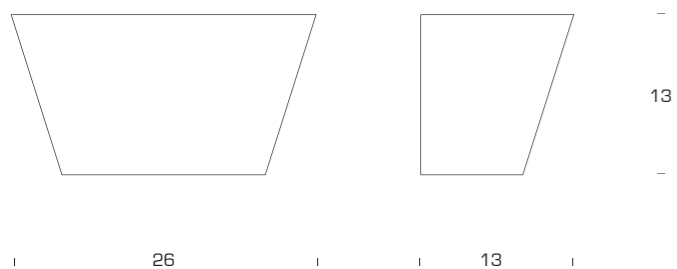

Lampada da parete.
Montatura in metallo.
Diffusore in vetro stratificato ambra (AM) o bianco (BI). Vetro di chiusura inferiore temperato e sabbiato. La lampada si presta a molteplici configurazioni.

Wall lamp. Metal mounting. Diffuser available in layered glass, amber (AM) or white (BI) colour. Bottom closure in tempered sandblasted glass. Thanks to its shape, Ananas may be set in different configurations.

Applique. Monture en métal. Diffuseur disponible en verre stratifié, couleur ambre (AM) ou blanc (BI). Verre de fermeture inférieure trempé et sablé. Grâce à sa forme, Ananas peut s'adapter à différentes configurations.

Wandlampe. Gestell aus Metall. Schirm aus bernsteinfarben (AM) oder weißem (BI) Glas. Unterer Abschluss aus Hartglas, matt. Viele Kombinationsmöglichkeiten.

Applique. Estructura de metal. Difusor de cristal estratificado ámbar (AM) o blanco (BI). Cristal de cierre inferior templado y arenado. Ananas se puede configurar de muchas formas.

M3302 + V3290..	21 x 10 x 11	☉ ☉	2x40W (IN) o/or 2x28W (HA) (ES) E14
M3303 + V3290..	21 x 10 x 11	☉	1x10W (FL) G24d-1
M3304 + V3290..	21 x 10 x 11	☉	1x48W (HA) (ES) R7s/80
M3302/1 + V3290/1..	26 x 13 x 13	☉ ☉	2x60W (IN) o/or 2x42W (HA) (ES) E14
M3303/1 + V3290/1..	26 x 13 x 13	☉	2x9W (FL) G24d-1
M3304/1 + V3290/1..	26 x 13 x 13	☉	1x80W (HA) (ES) R7s/80

CE IP20

M3302 - M3302/1

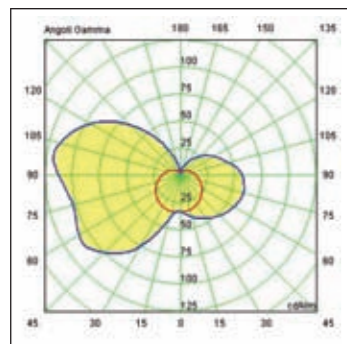

M3302 + V3290..

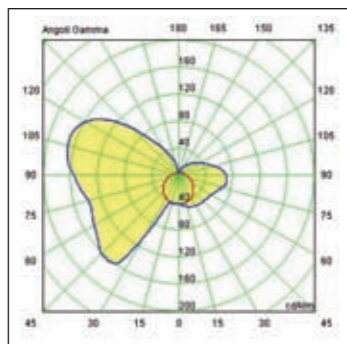

M3303 + V3290..

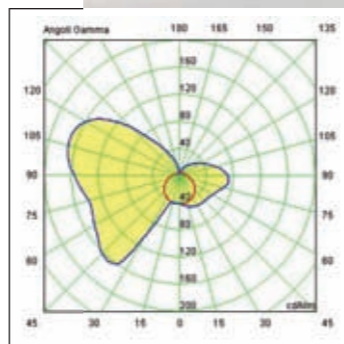

M3304 + V3290..

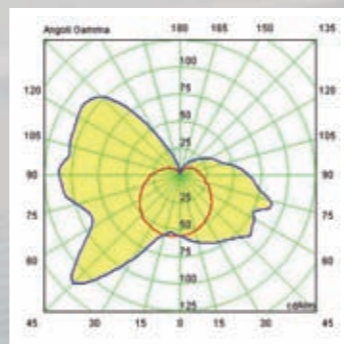

M3302/1 + V3290/1..

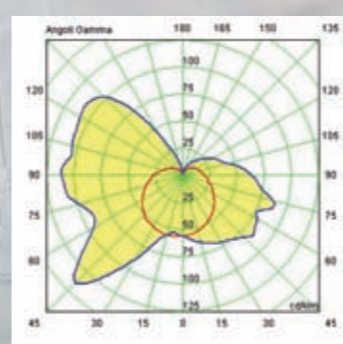

M3303/1 + V3290/1..

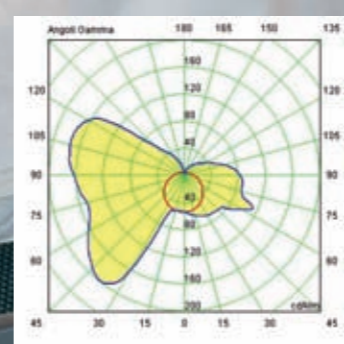

M3304/1 + V3290/1..



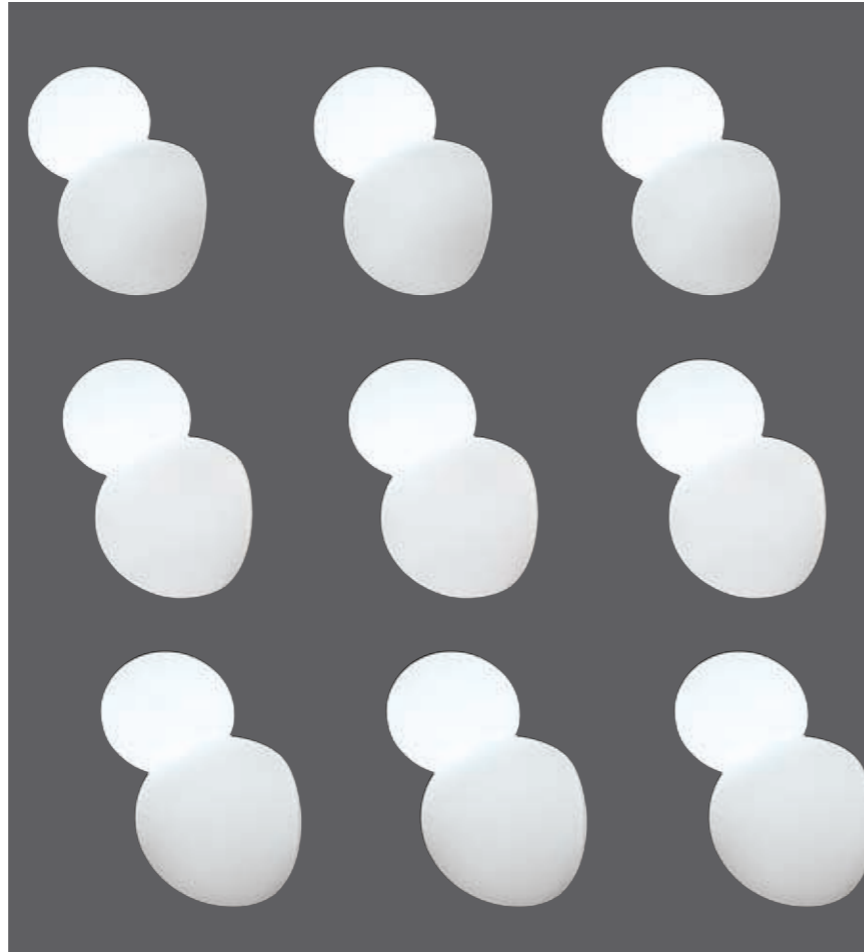

Lampada da parete.
Montatura in metallo
nichelato. Diffusore
in vetro soffiato satinato
bianco.

Wall lamp. Nickel-plated
metal structure. Diffuser
in white satin blown glass.

Applique. Structure en
métal nickelé. Diffuseur en
verre soufflé satiné blanc.

Wandlampe. Struktur aus
vernickeltem Metall.
Schirm aus mundge-
blasenem, weißem
satiniertem Glas.

Lámpara de pared.
Estructura de metal
niquelado. Difusor de
cristal soplado satinado
blanco.

3538 12 x 13 x 19 1x60W (IN) o/ or 1x42W (HA) ES E14

CE IP40

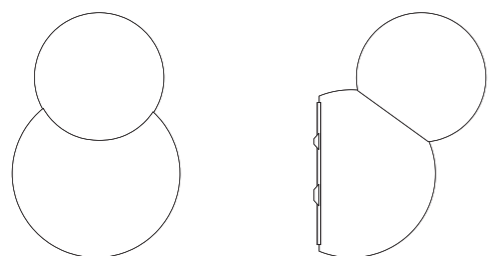

19

12

13



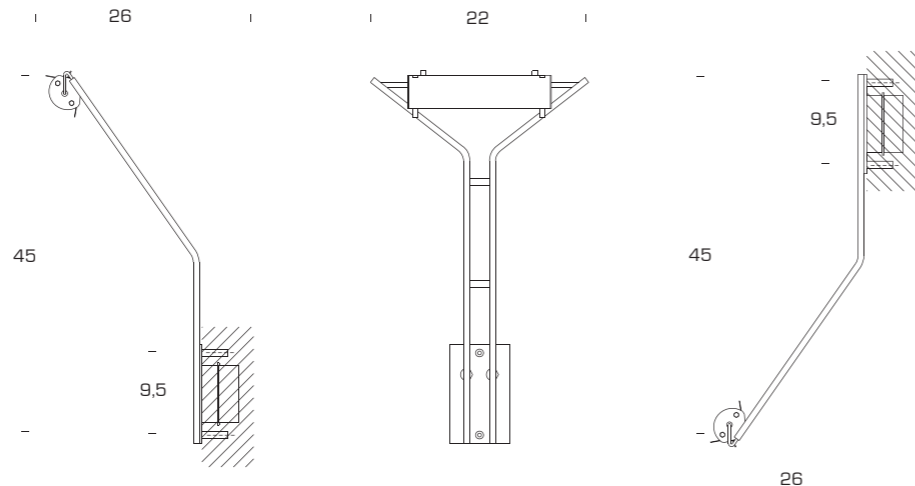

Lampada da parete. Struttura portalampana in acciaio cromato, piastra di fissaggio a parete in ottone cromato (CR) o nichelato satinato (NS). La lampada è fornita con schermi di sicurezza in vetro borosilicato, trasparenti e sabbiati. Riflettore per luce indiretta e distanziatore in metallo cromato o nichelato disponibili come accessori.

Wall lamp. Structure in chrome plated steel, fixing plate and tubes in chrome-plated (CR) or nickel-plated brass (NS). The appliance is provided with safety screen in borosilicate glass, transparent and sandblasted. Reflector for indirect light emission and spacer in chrome-plated or nickel-plated metal available as accessories.

Applique. Structure en acier chromé. Plaque de fixation et tige en laiton chromé (CR) ou nickelé satiné (NS). Dotée d'écrans de sécurité en verre borosilicate, transparents et sablés. Réflecteur pour éclairage indirect et entretoise en métal chromé ou satiné disponibles comme accessoires.

Wandleuchte. Gestell aus Chromstal. Platte zur Wandbefestigung und Lampenstiel aus Messing, verchromt (CR) oder satiniert vernickelt (NS). Die Leuchte wird mit transparenten und sandgestrahlten Sicherheitsblenden aus Borosilikatglas geliefert. Reflektor für indirekte Beleuchtung und Distanzstück aus verchromten oder vernickelten Metall verfügbar als Zubehör.

Lámpara de pared. Estructura de acero cromado. Lámina de fijado y tige de latón cromado (CR) o niquelado satinado (NS). Equipada de pantallas de seguridad en vidrio borosilicato, transparentes y arenados. Reflector para luz indirecta y distanciador en metal cromado o niquelado disponibles como accesorios.

RAT/P
riflettore (18 x 6,5 x 13)

RAT/P
reflector (18 x 6,5 x 13)

RAT/P
reflecteur (18 x 6,5 x 13)

RAT/P
Reflektor (18 x 6,5 x 13)

RAT/P
reflector (18 x 6,5 x 13)

DAC
distanziatore cromato (6,5 x 2,5 x 11)

DAC
chrome-plated spacer (6,5 x 2,5 x 11)

DAC
entretoise chromé (6,5 x 2,5 x 11)

DAC
verchromtes Distanzstück (6,5 x 2,5 x 11)

DAC
distanciador cromado (6,5 x 2,5 x 11)

DACNS
distanziatore nichelato satinato (6,5 x 2,5 x 11)

DACNS
nickel-plated satin spacer (6,5 x 2,5 x 11)

DACNS
entretoise nickel satiné (6,5 x 2,5 x 11)

DACNS
vernickeltes Distanzstück (6,5 x 2,5 x 11)

DACNS
distanciador niquelado (6,5 x 2,5 x 11)

2799CR/300	22 x 26 x 45		1x230W (HA)	R7s/115
2799NS/300	22 x 26 x 45		1x230W (HA)	R7s/115

IP20



2799CR/300 + RAT/P + DAC

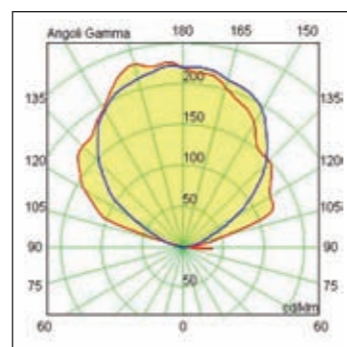

2799./300 + RAT/P

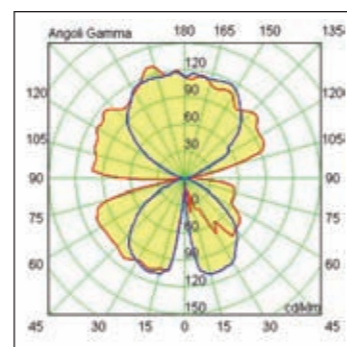

2799./300



4030BI/CR

Lampada da parete.
Diffusore superiore in vetro soffiato bianco opalino acidato. Diffusore inferiore in vetro centrifugato tipo midollino metallizzato esternamente. Puntali cilindrici per il blocco dei diffusori in metallo cromato. Montatura in metallo verniciato bianco.

4030BI/CR

Wall lamp. Upper diffuser in opal white blown acid-etched glass. Lower diffuser in spinning glass "midollino"-type with external metal sheathing. Cylindrical handgrip for the fixing of the diffusers in chrome-plated metal. Mounting in white painted metal.

4030BI/CR

Applique pour mur.
Diffuseur supérieur en verre soufflé blanc opalin traité al acide. Diffuseur inférieur en verre centrifugé type Midollino métallisé à l'extérieur. Embouts cylindriques pour bloquer les diffuseurs en métal chromé. Monture en métal verni blanc.

4030BI/CR

Wandleuchte mit oberem Streukörper aus weißem opal geätztem Glas. Unterer Streukörper aus zentrifugiertem Glas Typ "midollino", außen metallisiert. Zylindrische verchromte Metallspitzen zur Befestigung der Streukörper. Gestell aus weiß lackiertem Metall.

4030BI/CR

Lámpara para pared. Difusor superior de vidrio soplado blanco al ácido. Difusor inferior de vidrio centrifugado, tipo midollino metalizado externamente. Extremidades cilíndricas para el bloqueo de los difusores de metal cromado. Armadura de metal pintado blanco.

4031BI

Lampada da parete / plafone. Diffusore in vetro soffiato bianco opalino acidato. Puntali cilindrici per il blocco dei diffusori in metallo cromato. Montatura in metallo verniciato bianco.

4031BI

Wall/ceiling lamp. Diffuser made of opal white blown acid-etched glass. Cylindrical chrome-plated handgrip for the fixing of the diffusers. Mounting in white painted metal.

4031BI

Applique pour mur / plafond. Diffuseur en verre soufflé blanc opalin traité al acide. Embouts cylindriques pour bloquer les diffuseurs en métal chromé. Monture en métal verni blanc.

4031BI

Wand- und Deckenleuchte mit Streukörper aus weißem opal geätztem Glas. Zylindrische verchromte Metallspitzen zur Befestigung der Streukörper. Gestell aus weißem lackiertem Metall.

4031BI

Lámpara para pared / plafón. Difusor de vidrio soplado blanco opalino al ácido. Extremidades cilíndricas para el bloqueo de los difusores de metal cromado. Armadura de metal pintado blanco.

4030BI/CR	ø 25,3 x 13		1x100W (HA) or 1x20W (FL) E27
4031BI	ø 25 x 13		1x100W (HA) or 1x20W (FL) E27



4030BI/CR

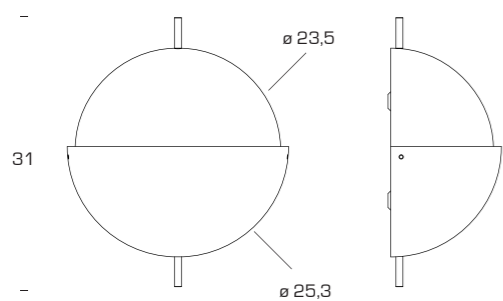

4031BI

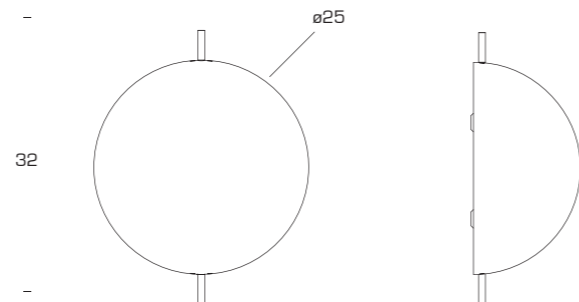



4030/1BI/CR

Lampada da parete.
Diffusore superiore in vetro soffiato bianco opalino acidato. Diffusore inferiore in vetro centrifugato tipo midollino metallizzato esternamente. Puntali cilindrici per il blocco dei diffusori in metallo cromato. Montatura in metallo verniciato bianco.

4030/1BI/CR

Wall lamp. Upper diffuser in opal white blown acid-etched glass. Lower diffuser in spinning glass "midollino"-type with external metal sheathing. Cylindrical handgrip for the fixing of the diffusers in chrome-plated metal. Mounting in white painted metal.

4030/1BI/CR

Applique pour mur.
Diffuseur supérieur en verre soufflé blanc opalin traité al acide. Diffuseur inférieur en verre centrifugé type Midollino métallisé à l'extérieur. Embouts cylindriques pour bloquer les diffuseurs en métal chromé. Monture en métal verni blanc.

4030/1BI/CR

Wandleuchte mit oberem Streukörper aus weißem opal geätztem Glas. Unterer Streukörper aus zentrifugiertem Glas Typ "midollino", außen metallisiert. Zylindrische verchromte Metallspitzen zur Befestigung der Streukörper. Gestell aus weiß lackiertem Metall.

4030/1BI/CR

Lámpara para pared. Difusor superior de vidrio soplado blanco al ácido. Difusor inferior de vidrio centrifugado, tipo midollino metalizado externamente. Extremidades cilíndricas para el bloqueo de los difusores de metal cromado. Armadura de metal pintado blanco.

4031/1BI

Lampada da parete / plafone. Diffusore in vetro soffiato bianco opalino acidato. Puntali cilindrici per il blocco dei diffusori in metallo cromato. Montatura in metallo verniciato bianco.

4031/1BI

Wall/ceiling lamp. Diffuser made of acid-etched white blown glass with satin finish. Cylindrical chrome-plated handgrip for the fixing of the diffusers. Mounting in white painted metal.

4031/1BI



Applique pour mur / plafond. Diffuseur en verre soufflé blanc opalin traité al acide. Embouts cylindriques pour bloquer les diffuseurs en métal chromé. Monture en métal verni blanc.

4031/1BI

Wand- und Deckenleuchte mit Streukörper aus weißem geätztem Glas. Zylindrische verchromte Metallspitzen zur Befestigung der Streukörper. Gestell aus weißem lackiertem Metall.

4031/1BI

Lámpara para pared / plafón. Difusor de vidrio soplado blanco opalino al ácido. Extremidades cilíndricas para el bloqueo de los difusores de metal cromado. Armadura de metal pintado blanco.

4030/1BI/CR	∅ 53,5 x 27,5		1x55W (FL) 2GX13
4031/1BI	∅ 50 x 25,5		1x55W (FL) 2GX13

  IP20

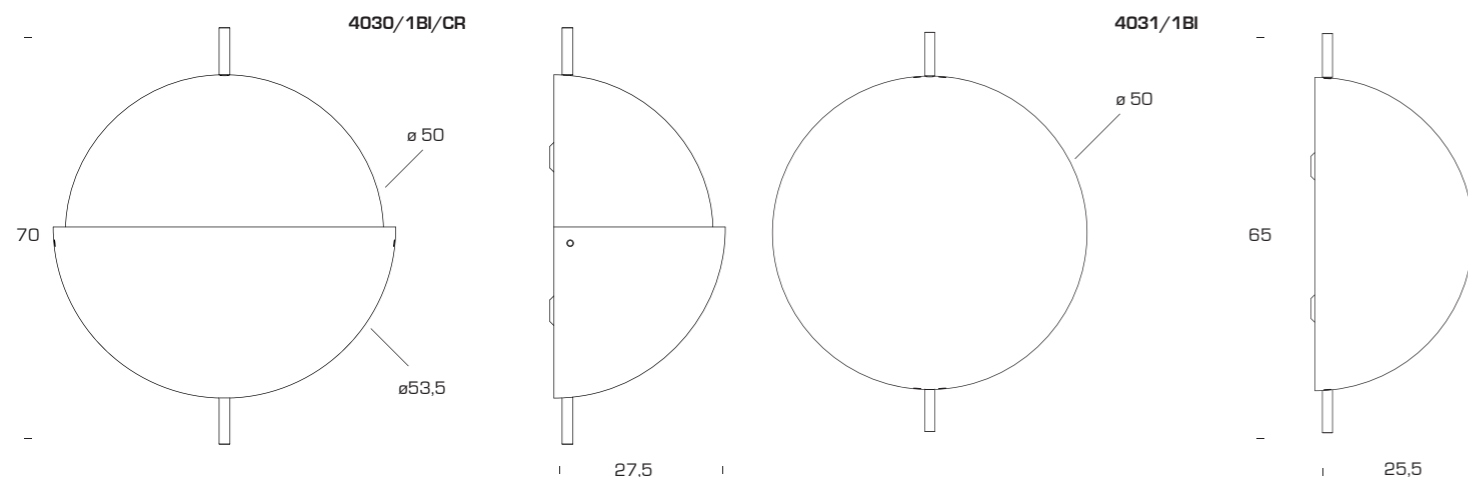

Corrubedo - Corrubedo Fluo

David Chipperfield 2005





Linee geometriche rigorose caratterizzano questa lampada da parete che offre luce diffusa verso il basso o verso l'alto. Parte frontale della lampada ricoperta da uno schermo in metallo lucido verniciato bianco (BI) oppure da uno specchio (SP). I diffusori laterali satinati emanano una luce delicata.

Straight-forward geometric lines characterize this wall lamp that offers diffused light emission upwards or downwards. Screen in polished white painted metal (BI) or with a mirror (SP) covering the frontal part of the lamp. Satin side diffusers in allow lateral and soft light.

De rigoureuses lignes géométriques caractérisent cette applique qui offre une émission de lumière diffuse directe vers le bas ou vers le haut. Un écran en métal verni blanc (BI) ou en miroir (SP) recouvre la partie frontale de la lampe. Deux diffuseurs latéraux satinés permettent une illumination douce.

Strenge geometrische Linien charakterisieren diese Wandleuchte, die die Lichtverteilung nach oben oder nach unten ermöglicht. Die Vorderseite besteht aus einer Blende die entweder weiß-glänzend lackiert ist (BI) oder einen Spiegel davor hat (SP). Die seitlichen Schirme sind satiniert zur harmonischen Lichtverteilung.

Las líneas geométricas rigurosas caracterizan este aplique, que ofrece una luz difusa orientada hacia abajo o hacia arriba. Una pantalla de metal con acabado blanco (BI) o de espejo (SP) cubre la parte frontal de la lámpara. Con los dos difusores laterales satinados se obtiene una iluminación soft.

5525.. BI - SP	20 x 20 x 7		1x40W o/or 1x33W (HA) 
3924.. BI - SP	21 x 30 x 8,5		1x27W (FL) E27

   IP20

5525..



20

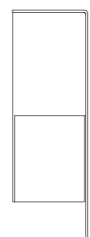

7

20

3924..

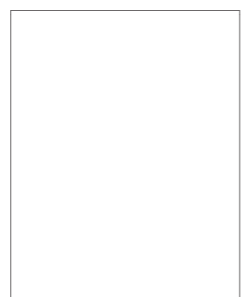

21



8,5

30

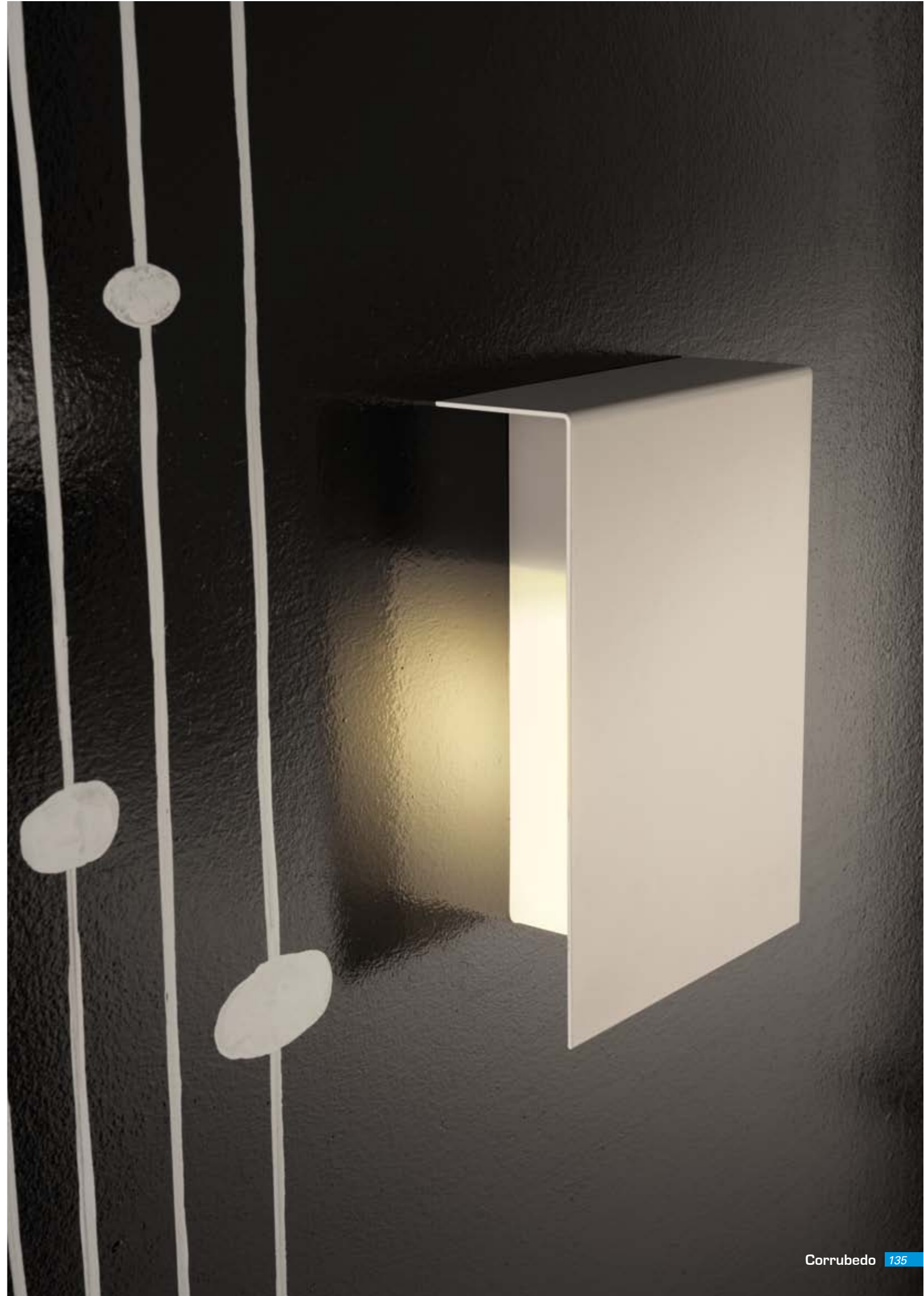

Diamante

Gae Aulenti/Piero Castiglioni 1986

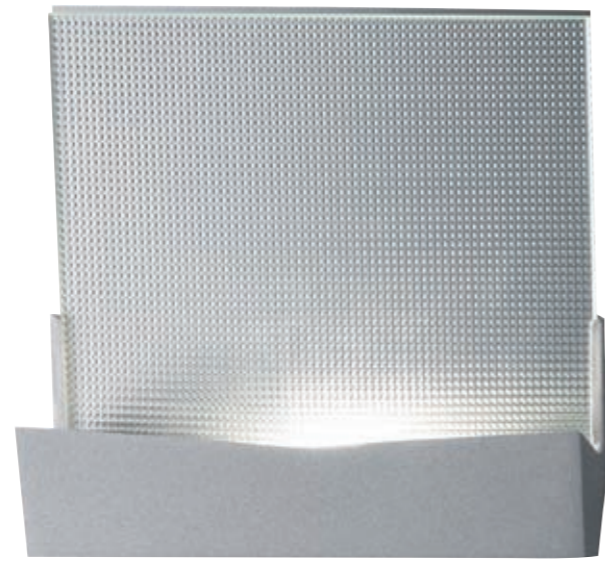

Lampada da parete.
Montatura in pressofusione di alluminio.
Diffusore in vetro stampato e temperato.

Wall lamp. Die-cast aluminium frame. Diffuser in pressed and tempered glass.

Applique. Monture en aluminium moulé sous pression. Diffuseur en verre pressé et trempé.

Wandlampe. Gestell aus Aluminium-Pressguss. Schirm aus Hartpressglas.

Applique de pared. Estructura de aluminio moldeada bajo presión. Difusor de cristal grabado y templado.

2762 25 x 8 x 25  1x160W (HA)  R7s/115

  IP20

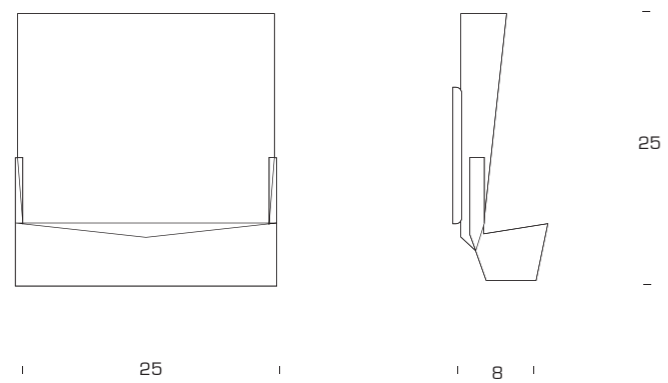

Marina B. Milano



Lampada da parete a bassa tensione con trasformatore elettronico a spina ed interruttore sul cavo per doppia intensità. Corpo orientabile in metallo cromato. Alette diffusori orientabili in alluminio anodizzato. Supporto in ottone cromato. Il collegamento elettrico fra la base e il corpo avviene tramite jack.

Low voltage wall lamp with electronic plug-type transformer and switch on the cable for double light intensity. Adjustable body in chrome-plated metal. Revolving diffuser wings in anodized aluminium. Chrome-plated brass wall support. A jack allows the electric connection between the wall support and the body.

Applique, à basse tension, avec transformateur électronique à prise et avec interrupteur à double intensité sur le câble. Corps orientable en métal chromé. Diffuseurs à ailettes orientables, en aluminium anodisé. Support en laiton chromé. La connexion électrique entre le support au mur et le corps est assurée par le biais d'une douille-jack.

Niederspannungs-Wandlampe mit elektronischem Trafo mit Stecker und Schalter auf dem Kabel für doppelte Schaltung. Verstellbarer Körper aus verchromtem Metall. Flügel-diffusor aus eloxiertem Aluminium. Ständer aus verchromtem Messing. Elektrische Verbindung zwischen Basis und Körper durch Anschaltklinke.

Lámpara de pared de baja tensión con transformador electrónico de clavija e interruptor en el cable para doble intensidad. Cuerpo orientable de metal cromado. Aletas difusoras orientables de aluminio anodizado. Soporte applique de latón cromado. La conexión entre la base y el cuerpo se produce mediante jack.

3016 corpo
3019 supporto

3016 body
3019 support

3016 corps
3019 support

3016 Körper
3019 Ständer

3016 cuerpo
3019 soporte

3016 + 3019 2,5 x 40 x 53 1x50W (HA) o/or 1 x35W (HA) (ES) GY6.35

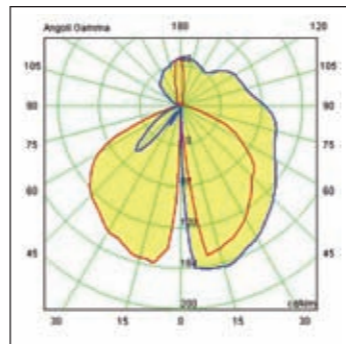
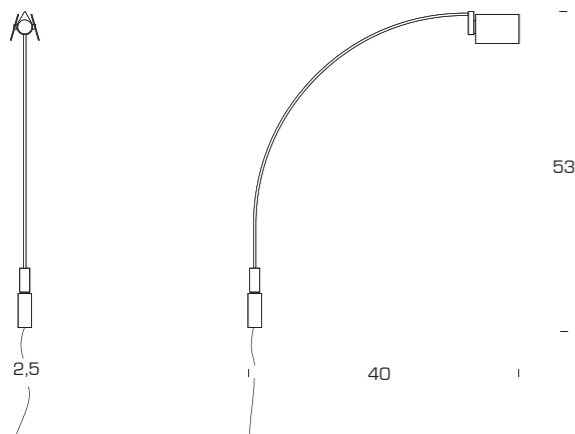

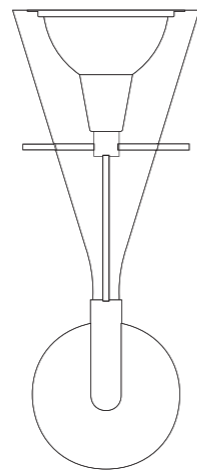

18

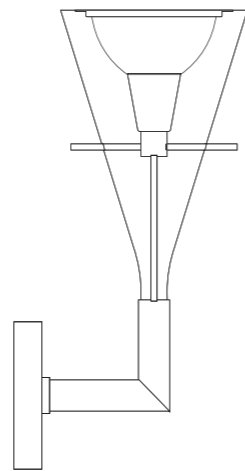

23

46

Lampada da parete.
Corpo in vetro borosilicato trasparente. Riflettore in alluminio cromato lucido. Supporto in metallo cromato. Il cono di vetro accoglie al suo interno il riflettore, sorretto da tre bracci cromati. La luce si riflette all'interno del cono e si diffonde in modo uniforme verso l'alto.

Wall lamp. Borosilicate transparent glass body. Reflector in chrome-plated polished aluminium. Chrome-plated metal support. The cone houses a reflector hold by three chrome-plated arms. The light reflects into the cone, thus giving a uniform light emission upwards.

Applique. Corps en verre de borosilicate transparent. Réflecteur en aluminium chromé brillant. Support en métal chromé. Le cône de verre accueille en son interne le réflecteur, soutenu par trois bras chromés. La lumière se reflète à l'intérieur du cône et se diffuse de manière uniforme vers le haut.

Wandlampe. Körper aus transparentem Borosilikat-Glas. Reflektor aus verchromtem glänzendem Aluminium. Gestell aus verchromtem Metall. Drei schmale horizontale Stäbe halten einen Kegel fest, der in seinem innerem die Fassung hat. Der Kegel reflektiert das Licht und dank des Glasstreukörper, der den Lichtstrahl nach oben orientiert, erhält man eine gleichmäßige Lichtverteilung innerhalb des Raumes.

Lámpara de pared. Cuerpo de cristal al borosilicato transparente. Reflector de aluminio cromado pulido. Soporte de metal cromado. La luz es reflejada dentro el cono y agradece al difuser que dirige la luz hacia arriba una emisión uniforme y difundida ligera de luz.

3314 18 x 23 x 48 1x205W (HA) E27

CE IP20

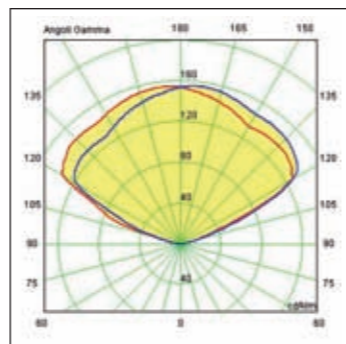

Globo di Luce

Roberto Menghi 1968



Lampada da parete. Doppia emissione di luce. Globo in vetro soffiato cromato. Montatura in metallo cromato.

Wall lamp. Double light emission. Chrome-plated blown glass globe. Mounting in chrome-plated metal.

Applique. Double émission de lumière. Globe en verre soufflé chromé. Monture en métal chromé.

Wandleuchte. Doppelte Lichtstrahlung. Kugel aus mundgeblasenem verchromtem Glas. Gestell aus verchromtem Metall.

Lámpara de pared. Doble emisión de luz. Globo en cristal soplado cromado. Estructura de metal cromado.

3842CR ø 20 x 25 x 18,5 2x40W (HA) o/ or 2x33W (HA) ES G9

CE IP20

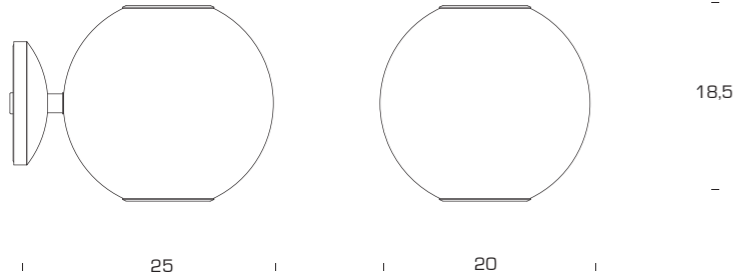



Lampada da parete. Corpo in tubo di acciaio conificato a freddo e poi cromato lucido. Doppia emissione luminosa: alogena indiretta nella parte superiore, a Led colore bianco come segnapasso nella parte inferiore. Alimentatore incluso.

Wall lamp. Body made of a steel tube, cold worked and then chrome-plated. Double light emission: indirect halogen upwards, Led white colour as guide light downwards. Ballast included.

Applique. Corps en acier travaillé à froid et chromé. Double émission de lumière: indirecte halogène pour la partie supérieure, avec Led blanche, comme indicateur de sentier lumineux dans la partie inférieure. Alimentateur inclus.

Wandleuchte. Körper aus poliertem und verchromten stabförmigen Stahl, kalt bearbeitet. Doppelte Lichtausstrahlung: halogene indirekte nach oben, mit Led weißfarben als Richtlinie nach unten. Vorschaltgerät inbegriffen.

Lámpara para pared. Cuerpo de tubo de acero conificado en frío cromado pulido. Doble emisión luminosa: alógena indirecta hacia arriba, de Led de color blanco como indicapaso hacia abajo. Alimentador incluido.

3905CR $\varnothing 8 \times 30 \times 180$ 1x150W (HA) B15d + 1x1W (Led)

IP20

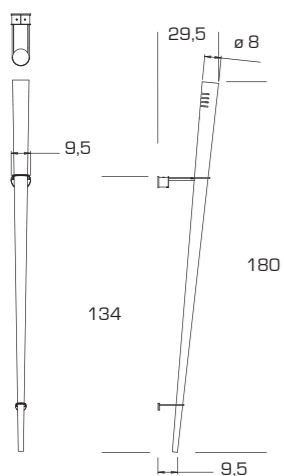

5446

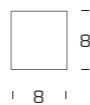
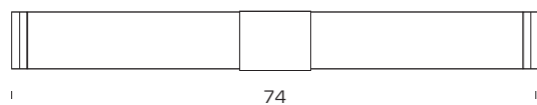

5446/1

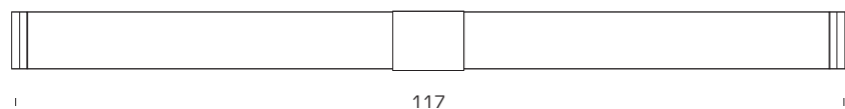



Lampada da parete.
Montatura in metallo
verniciato alluminio.
Diffusore in policarbonato
opalino con testate in
metacrilato trasparente.

Wall lamp. Aluminium-
painted structure.
Diffuser in opal polycarbo-
nate with tops in transpa-
rent methacrylate.

Applique. Structure en
m tal verni aluminium.
Diffuseur en polycarbona-
te opalin avec t tes en
m thacrylate transparent

Wandlampe. Struktur aus
aluminiumfarbig lackiertem
Metall. Schirm aus
opalfarbenem Polycarbo-
nat mit Stirnseiten aus
transparentem
Methacrylat.

L mpara de pared.
Estructura de metal
pintado aluminio. Difusor
de policarbonato opalino
con cabezas de
metacrilato transparente.

5446	74 x 8 x 8		2x24W 2G11 (FL)
5446/1	117 x 8 x 8		2x55W 2G11 (FL)

  IP20





Lampada da parete.
Struttura con due lastre
in metallo curvato
verniciato color nickel.

Wall lamp. Frame with
two curved nickel-painted
metal plates.

Applique. Structure avec
deux plaques en métal
courbé verni couleur
nickel.

Wandlampe. Struktur mit
zwei, nickel-lackierten,
gebogenen Metallplatten.

Applique de pared.
Estructura con dos
planchas de metal
curvado pintado color
nickel.

5333A 34 x 12 x 12   1x150W (HA)  or 1x20W (FL) E27

  IP20



34

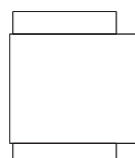

12

12

Lounge

Luisa Calvi / Mauro Merlini /
Carlos Moya 2003



Lampada da parete.
Montatura in metallo
verniciato alluminio.
Diffusore in metacrilato
arancione (AR) o traspa-
rente (TR) serigrafato.
Schermo di chiusura,
superiore e inferiore, in
vetro sabbato.

Wall lamp. Metal
mounting, aluminium
painted. Diffuser in
screen-printed methacry-
late available in orange
(AR) or in transparent
(TR) colour. Upper and
lower closing screen in
sandblasted glass.

Applique. Monture en
métal verni aluminium.
Diffuseur en méthacrylate
sérigraphié orange (AR)
ou transparent (TR).
Écrans de fermeture
supérieure et inférieure
en verre sablé.

Wandlampe. Struktur aus
aluminiumfarbig lackier-
tem Metall. Schirm aus
bedrucktem Methacrylat
orange (AR) oder
transparent (TR). Obere
und untere Abschlus-
sblende aus Sandglas.

Lámpara de pared.
Estructura de metal
pintado aluminio. Difusor
de metacrilato serigrafa-
do naranja (AR) o transpa-
rente (TR). Pantallas de
cierre, superior e inferior,
de cristal arenado.

5400.. AR - TR 17 x 20 x 13  1x150W (HA)  or 1x20W (FL) E27

   IP20

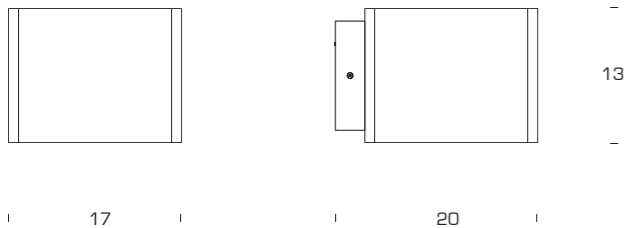



Lampada da parete.
Montatura in metallo
cromato. Diffusore
in vetro stampato.

Wall lamp. Chrome-plated
metal frame. Diffuser in
printed glass.

Applique. Monture en
métal chromé. Diffuseur
en verre imprimé.

Wandlampe. Gestell aus
verchromtem Metall.
Schirm aus gedrucktem
Glas.

Lámpara de pared.
Estructura de metal
cromado. Difusor de
cristal grabado.

3110VST/CR	9 x 8 x 30		1x18W (FL) 2G11
3111VST/CR	9 x 8 x 30		2x25W (IN) E14 o/or 2x18W (HA) E14
3112VST/CR	9 x 8 x 40		1x24W (FL) 2G11
3113VST/CR	9 x 8 x 40		2x40W (IN) E14 o/or 2x28W (HA) E14
3114VST/CR	9 x 8 x 60		1x36W (FL) 2G11
3115VST/CR	9 x 8 x 60		3x40W (IN) E14 o/or 3x28W (HA) E14

IP44

3110VST/CR - 3111VST/CR

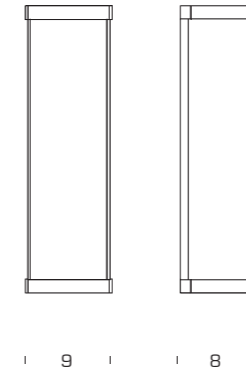

30

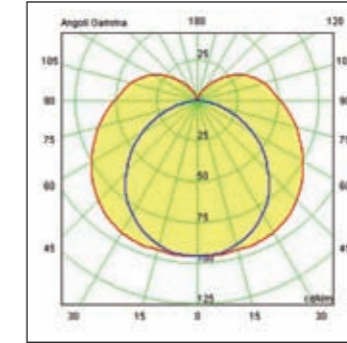

3110VST/CR

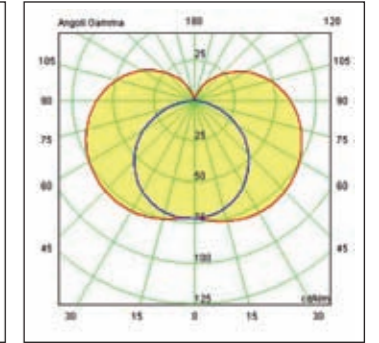

3111VST/CR

3112VST/CR - 3113VST/CR

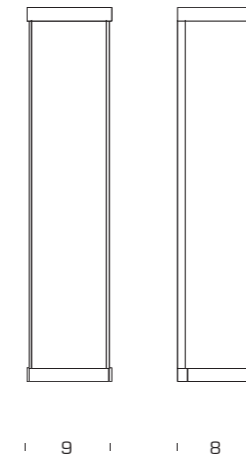

40

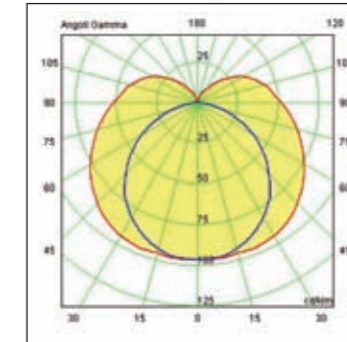

3112VST/CR

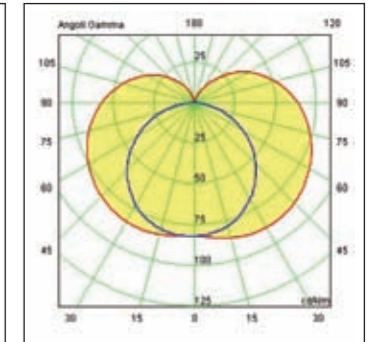

3113VST/CR

3114VST/CR - 3115VST/CR

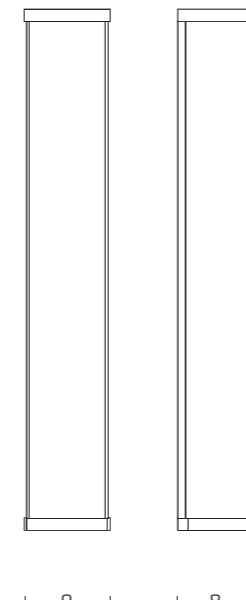
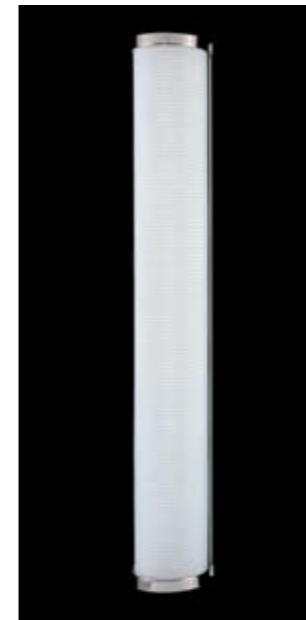

60

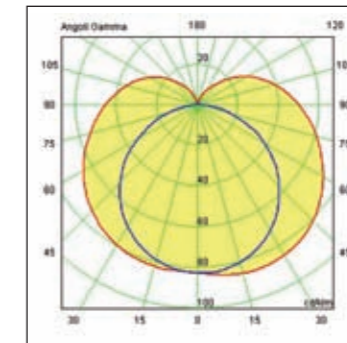

3114VST/CR

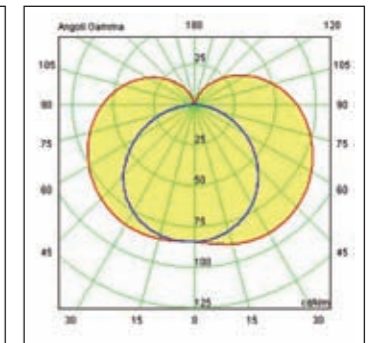

3115VST/CR

Naska 1, 2

Nasketta

1933

Lampada da parete con braccio orientabile in tutte le direzioni. Parabola in alluminio. Attacco a parete e parabola verniciata nei colori alluminio (A), bianco (BI), cromato (CR) o nero opaco (NO). Disponibile anche nella versione Led.

Wall lamp with revolving bracket in all directions. Parabola in aluminium. Wall socket and parabola are painted in the following colours: aluminium (A), white (BI), chrome (CR) or matt black (NO). Available in the Led version too.

Applique avec bras orientables dans toutes les directions. Parabole en aluminium. Fixation murale et parabole vernies en aluminium (A), blanc (BI), chromé (CR) ou noir opaque (NO). Disponible aussi à la version Led.

Wandlampe mit in allen Richtungen orientierbarem Arm. Stiel ist aus Stahl. Wandsockel und Parabel aus Aluminium, aluminiumfarben (A), weiß (BI), verchromt (CR) oder matt schwarz (NO) lackiert. Verfügbar auch die Version mit Led.

Lámpara de pared con brazo orientable en todas las direcciones. Parabola de aluminio. Enganche de pared y parabola pintado en color aluminio (A), blanco (BI), cromado (CR) o negro opaco (NO). Disponible también la versión con Led.











8103.. A - BI - CR - NO
supporto a parete





8103.. A - BI - CR - NO
walls upport

8103.. A - BI - CR - NO
fixation murale

8103.. A - BI - CR - NO
Wandsockel

8103.. A - BI - CR - NO
soporte de pared

8000.. A - BI - NO	corpo / body / corps / Körper / cuerpo	 	1x60W (IN) o/ or 1x42W (HA)  E27
8001.. A - BI - NO	corpo / body / corps / Körper / cuerpo	 	1x60W (IN) o/ or 1x42W (HA)  E27
8004.. A - BI - NO	corpo / body / corps / Körper / cuerpo	 	1x40W (IN) o/ or 1x28W (HA)  E27
8010.* A - BI - CR - NO	corpo / body / corps / Körper / cuerpo		3x3W 700mA (Led)
8011.* A - BI - CR - NO	corpo / body / corps / Körper / cuerpo		3x3W 700mA (Led)

     8000.. - 8001.. - 8004 * temperatura di colore / colour temperature / température de couleur / Farbtemperatur / temperatura de color 3000°K alimentatore incluso / ballast included / alimentateur inclus / Vorschaltgerät inbegriffen / alimentador incluido

Naska 1

8000.. - 8010.. A - BI - CR - NO + 8103.. A - BI - CR - NO

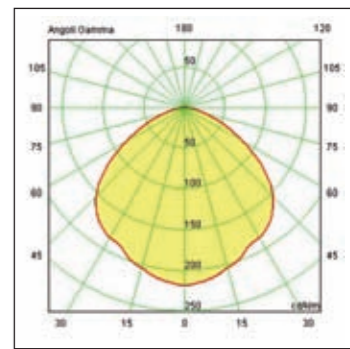
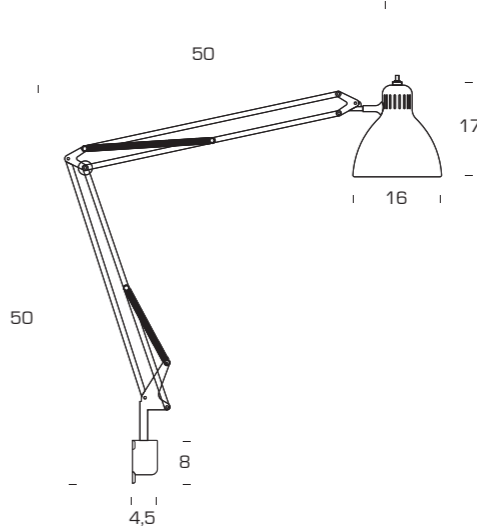

Naska 2

8001.. - 8011.. A - BI - CR - NO + 8103.. A - BI - CR - NO

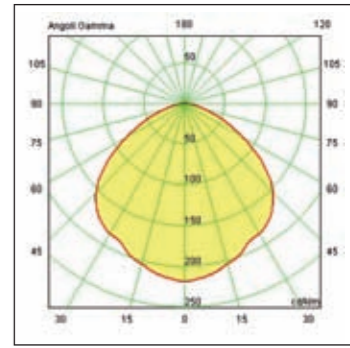
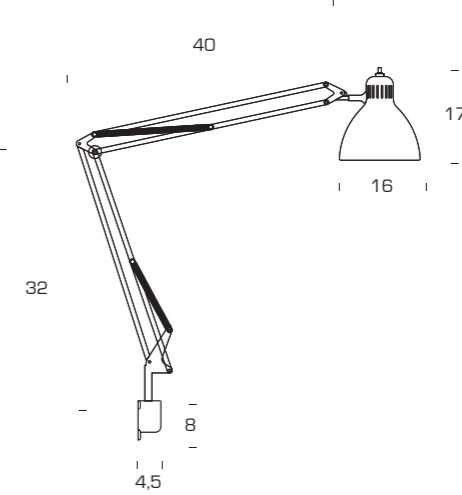

Nasketta

8004.. A - BI - CR - NO + 8103.. A - BI - CR - NO

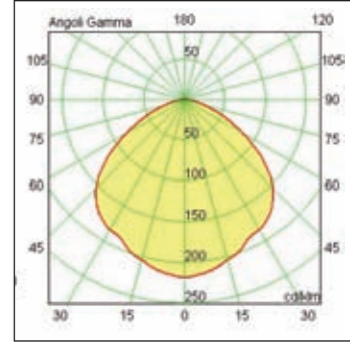
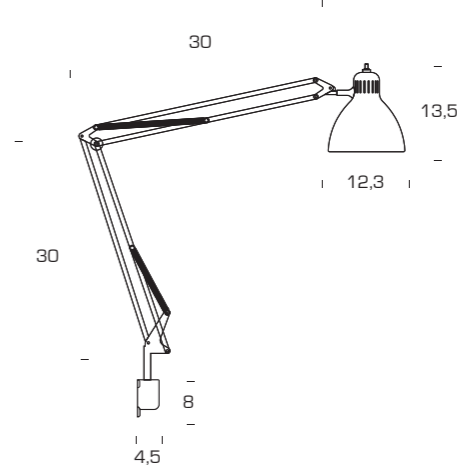

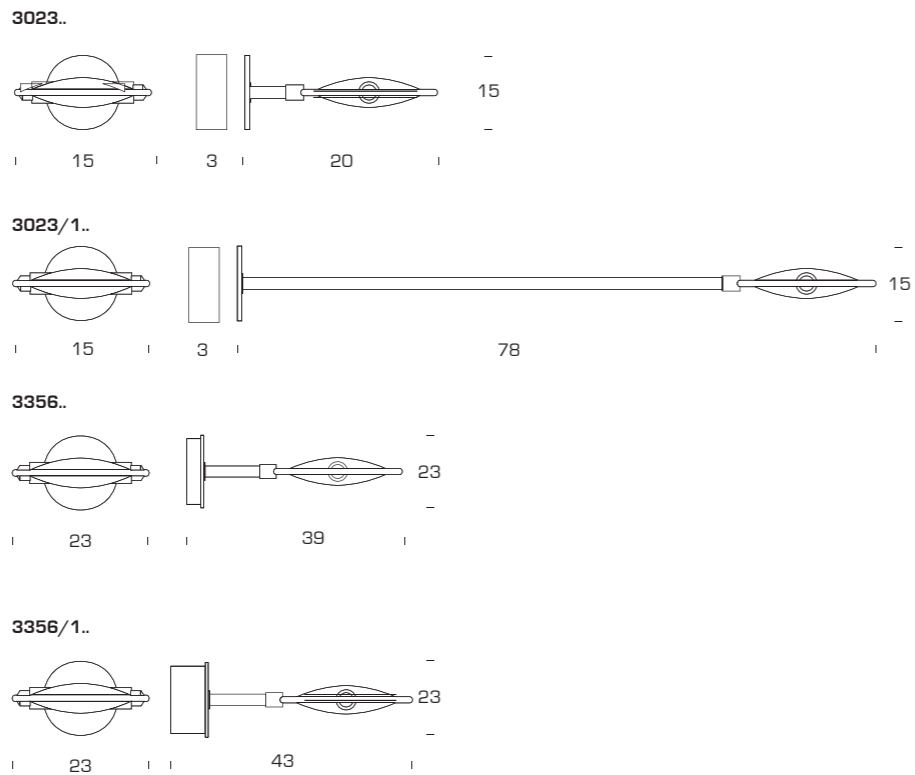

Lampada da parete. Montatura in metallo cromato (CR), verniciato grigio alluminio (G) oppure nichelato satinato (NS). La lampada è fornita con un riflettore in alluminio anodizzato per luce indiretta, diffusori in vetro stampato, temperato e sabbato e un distanziatore per connessioni elettriche (ø cm 8x3, per modelli 3023.. e 3023/1..).

Wall lamp. Mounting in chrome-plated (CR), grey aluminium painted (G) or nickel-plated satin (NS) metal. The lamp is provided with a reflector in anodized aluminium for indirect light emission, diffusers in printed glass, tempered and sand-blasted and a spacer for electrical connections (ø cm 8x3, for models 3023.. and 3023/1..).

Applique. Monture en métal chrome (CR), verni gris aluminium (G) ou nickelé satiné (NS). La lampe est équipée de réflecteur pour éclairage indirect, de diffuseurs en verre pressé, sablé et trempé et d'une entretoise pour les connexions électriques (ø cm 8x3, pour modèles 3023.. et 3023/1..).

Wandleuchte. Gestell aus verchromtem (CR), grau lackiertem (G) oder satiniertem Vernickeltem Metall (NS). Der Leuchtkörper ist mit einem Reflektor für indirekte Beleuchtung, Schirmen aus bedrucktem und sandgestrahltem Sicherheitsschirmen ausgestattet und ein Distanzstück für die Stromversorgung (ø cm 8x3, für Modelle 3023.. und 3023/1..).

Lámpara de pared. Estructura de metal cromado (CR), pintada gris aluminium (G) o niquelada satinada (NS). El aparato está equipado de un reflector para luz indirecta, difusores de cristal grabado, templado y arenado y un separador para conexions eléctricas (ø cm 8x3 para los modelos 3023.. y 3023/1..).

CAT.. CR - G - NS
distanziatore (ricambio)

CAT.. CR - G - NS
spacer (spare part)

CAT.. CR - G - NS
boîte entretoise (pièce de rechange)

CAT.. CR - G - NS
Distanzstück (Ersatzteil)

CAT.. CR - G - NS
distanziador (pieza de recambio)

3023.. - 3023/1.. CR - G - NS	ø 15 x 20-78	↔	1x120W (HA) (ES) R7s/80
3356.. CR - G - NS	ø 23 x 39	↔	1x230W (HA) (ES) R7s/80
3356/1.. CR - G - NS	ø 23 x 43	↔	1x230W (HA) (ES) R7s/115

CE IP40 3356..-3023.. 3356..-3356/1..

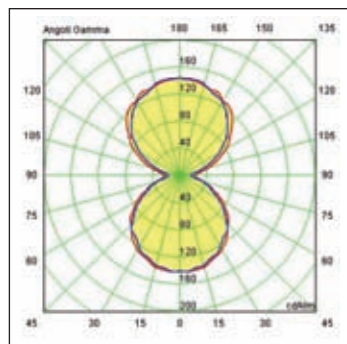

3023..

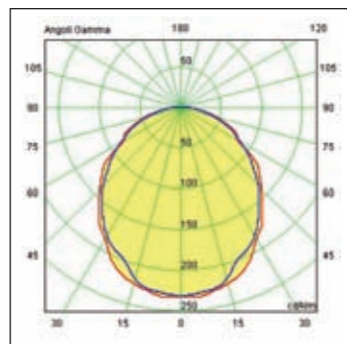

3023.. + Riflettore/reflector

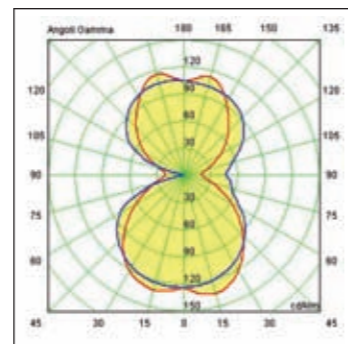

3356..

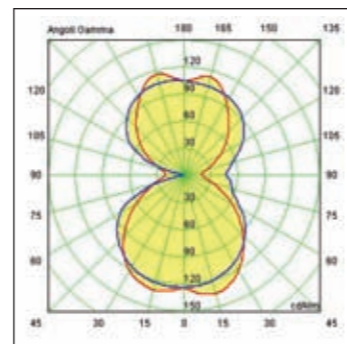

3356/1..

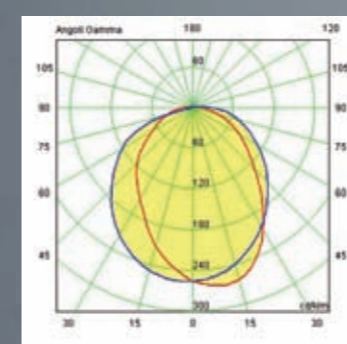

3356.. + Riflettore/reflector

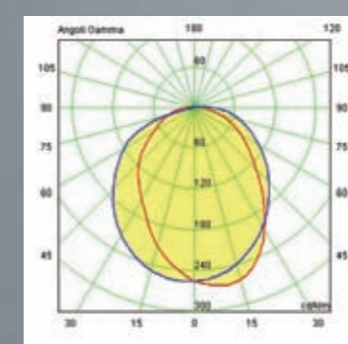

3356/1.. + Riflettore/reflector





Lampada da parete a due luci. Montatura in metallo cromato (CR), verniciato grigio (G) o nichelato satinato (NS). La lampada è fornita con diffusori in vetro stampato, sabbato e temperato e un distanziatore.

Wall lamp with two shades. Mounting in chrome-plated (CR), grey painted (G) or satin nickel-plated (NS) metal. The lamp is provided with diffusers in pressed, sandblasted, tempered glass and a spacer.

Applique à deux éclairages. Structure en métal chromé (CR), vernis gris (G) ou nickelé satiné (NS). La lampe est livrée avec des diffuseurs en verre moulé, sablé et trempé et une boîte entretoise.

2-flammige Wandleuchte. Struktur aus Metall, verchromt (CR), grau lackiert (G) oder satiniert vernickelt (NS). Schirme aus bedrucktem und sandgestrahltem Sicherheitsglas und Distanzstück inbegriffen.

Lámpara de pared de dos luces. Estructura del metal cromado (CR), pintado gris (G) o niquelado satinado (NS). Difusores de vidrio arenado grabado y templado y distanciador incluido.



R3086S
riflettore

R3086S
reflector

R3086S
reflecteur

R3086S
Reflektor

R3086S
reflector

3595.. CR - G - NS 39 x 25 x 9  2x120W (HA)  R7s/80

     IP40

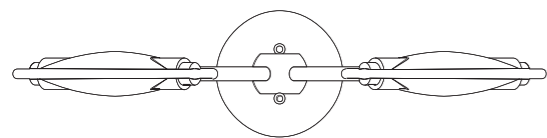

39

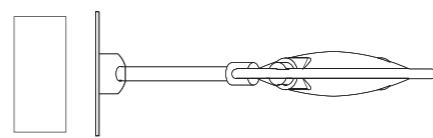

25

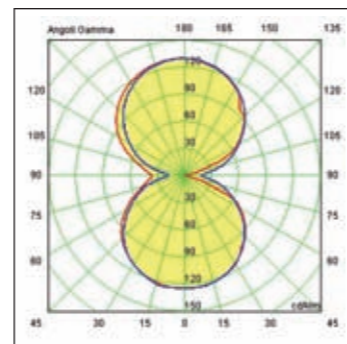



Lampada da parete.
Diffusore in vetro soffiato
bianco (BI) oppure a
specchio (SP). Montatura
in metallico verniciato
bianco.

Wall lamp. Blown glass
diffuser, available white
(BI) or mirror-finish (SP).
Wall support in white
painted metal.

Applique. Diffuseur en
verre soufflé couleur
blanc (BI) ou à miroir (SP).
Culot métallique verni
blanc.

Wandlampe. Schirm aus
mundgeblasenem Glass,
erhältlich weiß (BI) oder
blankpoliert (SP).
Wandbefestigung aus
weißem lackiertem Metall.

Lámpara de pared.
Difusor de cristal soplado,
blanco (BI) o a espejo
(SP). Soporte pared de
metal pintado blanco.





Modello comunitario
depositato

Design patent pending

Modèle communautaire
déposé

Eingetragenes
Warenzeichen

Modelo comunitario
depositado

3890/0.. BI - SP	∅ 20 x 9,5		1x60W (HA)  G9
3890.. BI - SP	∅ 40 x 17		1x140W (HA)  R7s/80

  IP20

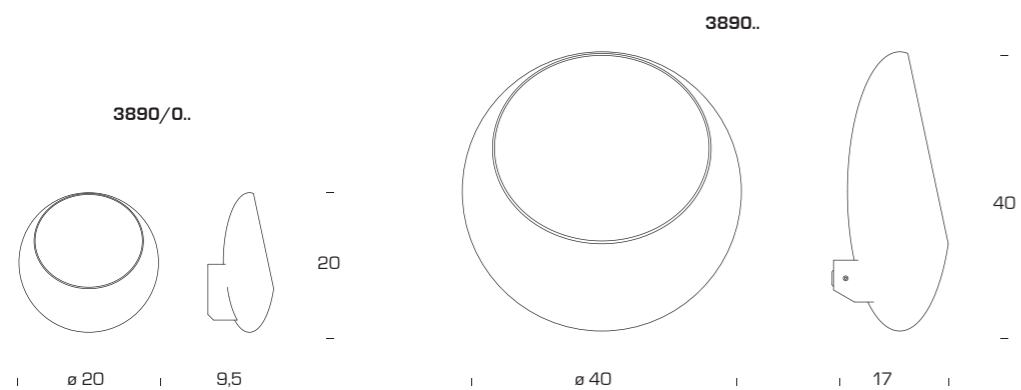



Lampada da parete.
Montatura in ottone
nichelato. Diffusore in
vetro soffiato opalino
ambra (AM) oppure
bianco (BI).

Wall lamp. Nickel-plated
brass frame. Diffuser in
amber (AM) or white (BI)
opal blown glass.

Applique. Monture en
laiton nickelé. Diffuseur en
verre soufflé opalin couleur
ambre (AM) ou blanc (BI).

Wandlampe. Gestell aus
vernickeltem Messing.
Schirm aus opalenem,
geblasenem Glas. Farben:
bernstein (AM), weiß (BI).

Lámpara de pared.
Estructura de latón
niquelado. Difusor de
cristal soplado opalino
ámbar (AM), blanco (BI).

M26890N
montatura

M26890N
frame

M26890N
monture

M26890N
Gestell

M26890N
estructura

V2689.. AM - BI
diffusore

V2689.. AM - BI
diffuser

V2689.. AM - BI
diffuseur

V2689.. AM - BI
Schirm

V2689.. AM - BI
difusor

M26890N +V2689.. AM - BI 20 x 23 x 30 1x150W (HA) B15d

IP20

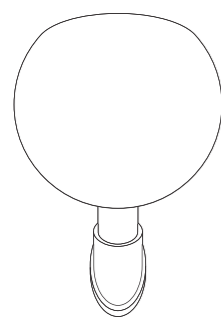

20

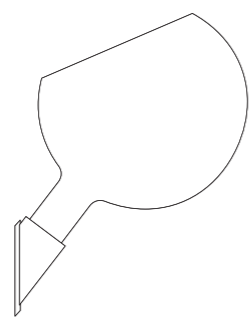

23

30



Lampada da parete. Montatura in acciaio inox lucido (AXL), metallo nichelato spazzolato (NS) o trattato con vernice antiriflesso e antigraffio color alluminio (AA), bianco (BI) o grigio (GA). Diffusori in vetro temperato sabbato.

Wall lamp. Frame in stainless steel (AXL), brushed nickel-plated (NS) or non-reflecting and non scratch varnish aluminium-coloured metal (AA), white (BI) or grey (GA). Tempered sandblasted glass diffusers.

Applique. Monture en acier inox brillant (AXL), en métal nickelé satiné (NS) ou traité par peinture antireflet et inrayable couleur aluminium (AA) blanc (BI) ou gris (GA). Diffuseurs en verre trempé sablé.

Wandlampe. Gestell aus poliertem Edelstahl (AXL), vernickeltem, gebürstetem Metall (NS) oder mit blendfreier und kratzfester Lackierung aluminiumfarben (AA), weiß (BI) oder grau (GA). Schirm aus sandgestrahltem gehärtetem Glas.

Aplique de pared. Estructura de acero inoxidable brillante (AXL) de metal niquelado satinado (NS) o tratado con pintura antirreflejo y antirrayado de color aluminio (AA) blanco (BI) o gris (GA). Difusor de cristal templado arenado.

5214.AA - BI - GA - AXL - NS	36 x 7 x 7		1x80W (HA) R7s/80
5214/1.. AA - BI - GA - AXL - NS	70 x 9 x 7		2x80W (HA) R7s/80
5214/2.. AA - BI - GA - AXL - NS	141 x 12 x 8		3x120W (HA) R7s/115
5244.. AA - BI - GA - AXL - NS	70 x 9 x 7		2x15W (FL) E27
5244/2.. AA - BI - GA - AXL - NS	141 x 12 x 8		2x39W (FL) G5
5392/1.. AA - BI - GA - AXL - NS	105 x 8 x 5		1x24W (FL) G5
5398.. AA - BI - GA - AXL - NS	56 x 9 x 7		1x120W (HA) R7s/115
5404.. AA - BI - GA - AXL - NS	56 x 9 x 7		1x26W (FL) G24d-3
5405/1.. AA - BI - GA - AXL - NS	70 x 9 x 7		1x36W (FL) 2G11
5406/1 AA - BI - GA - AXL - NS	105 x 8 x 5		2x80W (HA) R7s/80

IP20 5214..5214/1..5244..5406/1 5214..5214/1..5244..



5214..

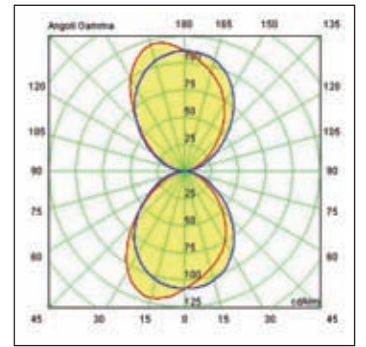
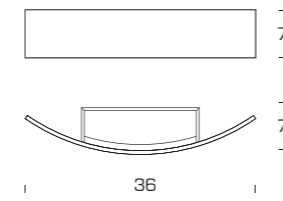

5398.. - 5404..

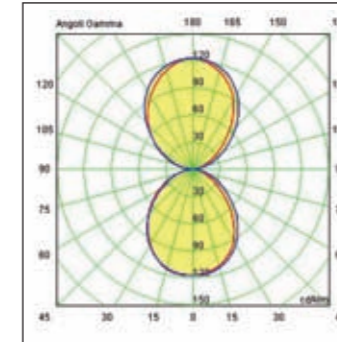
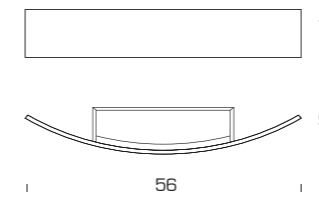

5398..

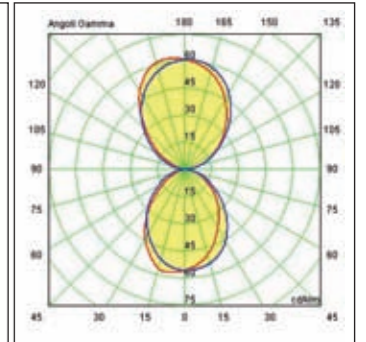

5404..

5214/1.. - 5244.. - 5405/1..

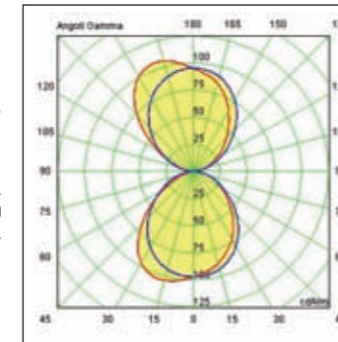
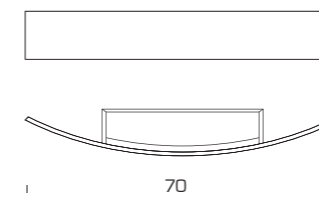

5214/1..

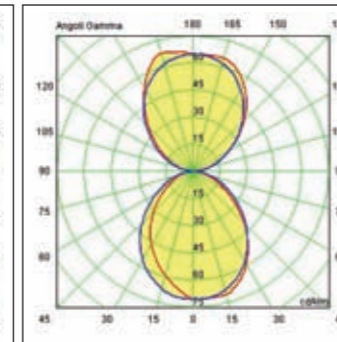

5244..

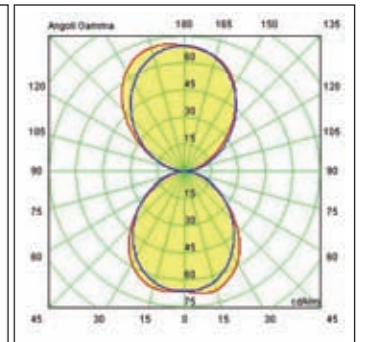

5405/1..

5392/1.. - 5406/1..

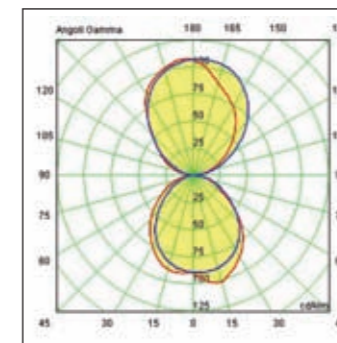
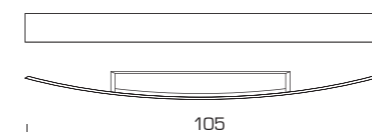

5392/1..

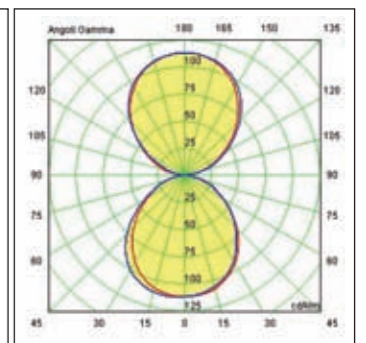

5406/1..

5214/2.. - 5244/2..

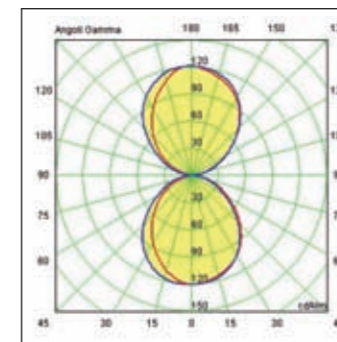
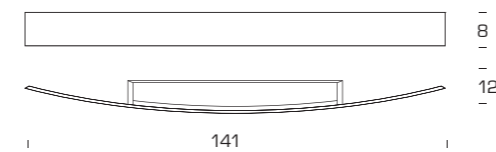

5214/2..

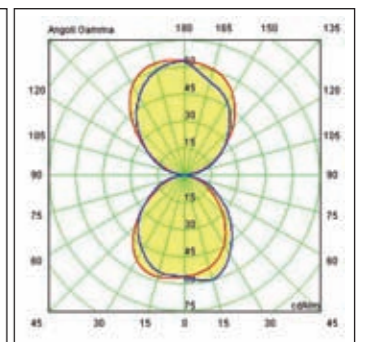

5244/2..





Lampada da parete.
Montatura in metallo
colore alluminio (A) con
diffusore in policarbonato
colore avorio serigrafato
internamente oppure
montatura in metallo
cromato (CR/BI) con
diffusore in policarbonato
bianco ottico.

Wall lamp. Mounting in
grey colour aluminium (A)
with polycarbonate
diffuser in ivory colour,
silkscreened inside, or
mounting in chrome-
plated metal (CR/BI) with
white optical diffuser in
polycarbonate.

Applique. Monture en
métal verni aluminium (A)
avec diffuseur en polycar-
bonate couleur ivoire,
sérigraphié intérieure-
ment, ou monture en
metal chromé (CR/BI)
avec diffuseur en polycar-
bonate couleur blanc
optique.

Wandlampe. Gestell aus
aluminiumfarbenem
Metall (A) umit Schirm
aus Elfenbeinfarbenem
Polykarbonat, innen
siebgedruckt, oder Gestell
aus verchromtem Metall
(CR/BI) mit Schirm aus
weißem optischem
Polykarbonat.

Lámpara de pared.
Estructura de metal
pintado color aluminio (A)
con difusor de policarbo-
nato blanco marfil,
serigrafado en el interior,
o estructura de metal cro-
mado (CR/BI) con difusor
de policarbonato blanco
óptico.

5155.. A - CR/BI 22 x 12 x 17  1x42W (HA)  E14

      IP20

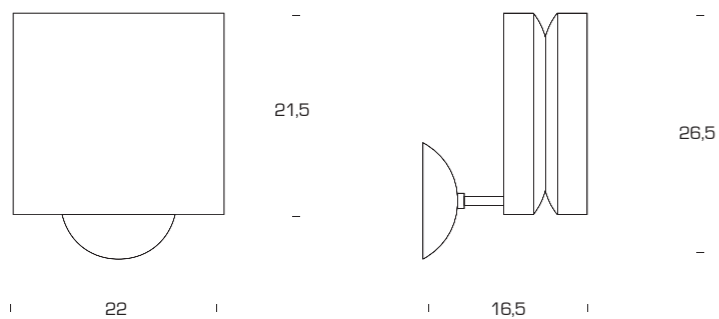

Scintilla AT1P

Livio / Piero Castiglioni 1972



Lampada da parete. Struttura e attacco a parete in acciaio cromato (CR) o nichelato satinato (NS). Schermi di sicurezza in vetro borosilicato trasparente e sabbato.

Wall lamp. Structure and wall mounting in chrome-plated (CR) or satin nickel-plated (NS) steel. Safety screens in transparent and sandblasted borosilicate glass.

Applique. Structure et fixation murale en acier chromé (CR) ou nickelé satiné (NS). Ecrans de sécurité en verre borosilicate transparents et sablés.

Wandlampe. Struktur und Wandbefestigung aus verchromtem (CR) oder vernickeltem satiniertem (NS) Stahl. Sicherheitsblenden aus transparentem und sandgestrahltem Borosilikatglas.

Lámpara de pared. Estructura y fijación a pared de acero cromado (CR) o niquelado satinado (NS). Pantallas de seguridad en vidrio borosilicato transparente y arenado.

RAT/P
riflettore (18 x 6,5 x 13)

RAT/P
reflector (18 x 6,5 x 13)

RAT/P
reflecteur (18 x 6,5 x 13)

RAT/P
reflecteur (18 x 6,5 x 13)

RAT/P
reflecteur (18 x 6,5 x 13)

AT1P150.. CR - NS	15 x 14 x 14		1x120W (HA)	R7s/80
AT1P300.. CR - NS	19 x 18 x 15		1x230W (HA)	R7s/80
AT1PM300.. CR - NS	19 x 18 x 200		1x230W (HA)	R7s/80

IP20

AT1P150..

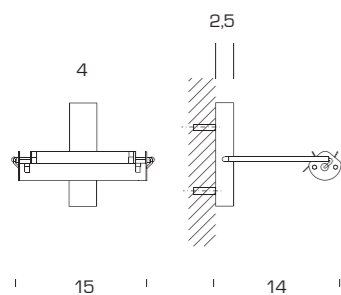

AT1P300..

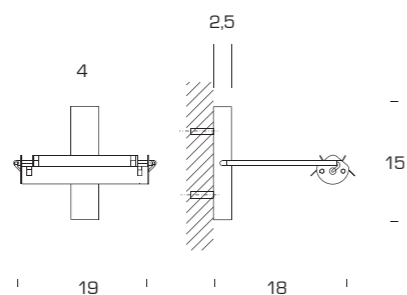

AT1PM300..

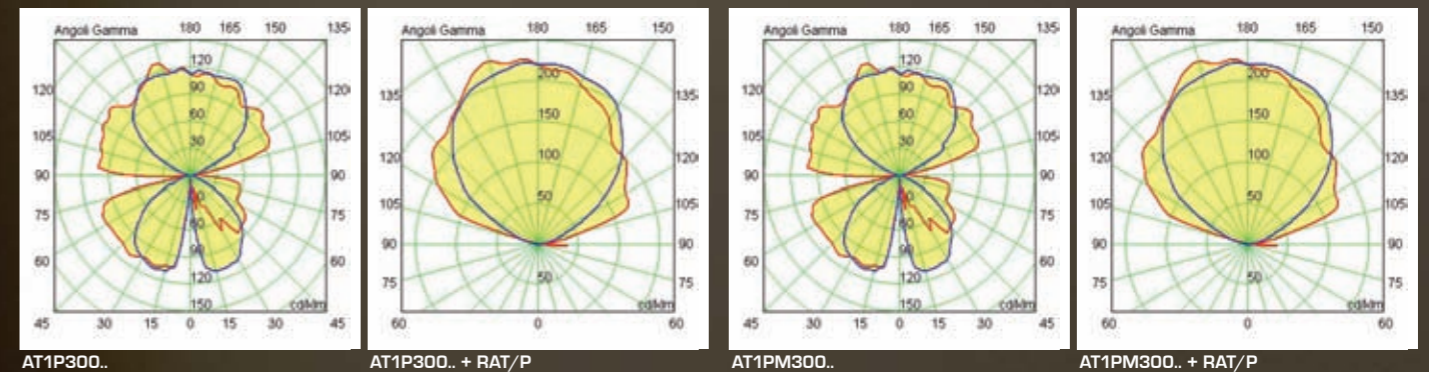
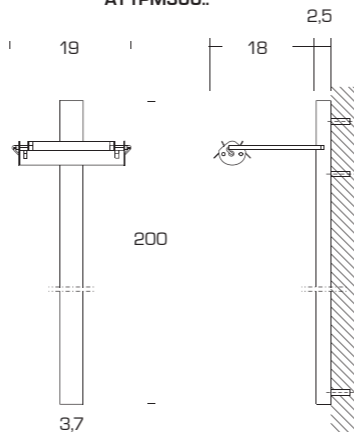

AT1P300..

AT1P300.. + RAT/P

AT1PM300..

AT1PM300.. + RAT/P



Lampade da parete con cascata verticale da 1 a 5 lampadine a bassa tensione. Piattello in acciaio inox, portalam-pada in steatite, bacchette in rame cromato, distanziatori in vetro borosilicato. Le bacchette in rame consentono di portare l'alimentazione a bassa tensione dalla parete alla lampadina senza la presenza di cavo elettrico. Trasformatore a richiesta (non incluso).

Wall lamp with vertical cascade housing from 1 up to 5 low-voltage bulbs. Plate in stainless steel, bulb-holder in steatite, stays in chrome-plated copper, spacer in borosilicate glass. The copper stays allow the low voltage power supply to be transferred from the wall to the bulb without the presence of electric wires. Transformer upon request (not included).

Applique à cascade verticale de 1 à 5 ampoules à basse tension. Plateau en acier inox, porte-lampe en stéatite, tiges en cuivre chromé, entretoise en verre borosilicate. Les tiges en cuivre permettent une alimentation à basse tension, du mur à l'ampoule, sans la présence de câble électrique. Transformateur sur demande (non inclus).

Wandlampe mit senkrechter Kaskade von 1 bis zu 5 Niederspannungslampen bestückt. Platte aus Edelstahl, Fassung aus Speckstein, Stäbe aus verchromtem Kupfer, Distanzstück aus Borosilikatglas. Durch die Kupferstäbe ist die Niederspannungsversorgung von der Wand bis zur Lampe ohne Netzkabel möglich. Transformator wird auf Wunsch mitgeliefert (nicht inbegriffen).

Lámpara de pared con casacada vertical de 1 a 5 bombillas de baja tensión. Platillo de acero inoxidable, portalam-pada de esteatita, varitas de cobre cromado, distanciadador en vidrio borosilicate. Las varitas de cobre permiten llevar la alimentación a baja tensión de la pared a la bombilla sin la presencia de cable eléctrico. Transformador opcional (non incluido).

BT1P50/T	15 x 11 x 24	⇒	1x35W (ES) o/or 1x50W 12V (HA) GY6.35
BT2P50/T	15 x 11 x 37	⇒	2x35W (ES) o/or 2x50W 12V (HA) GY6.35
BT3P50/T	15 x 11 x 50	⇒	3x35W (ES) o/or 3x50W 12V (HA) GY6.35
BT4P50/T	15 x 11 x 63	⇒	4x35W (ES) o/or 4x50W 12V (HA) GY6.35
BT5P50/T	15 x 11 x 76	⇒	5x35W (ES) o/or 5x50W 12V (HA) GY6.35

CE Classe III IP20

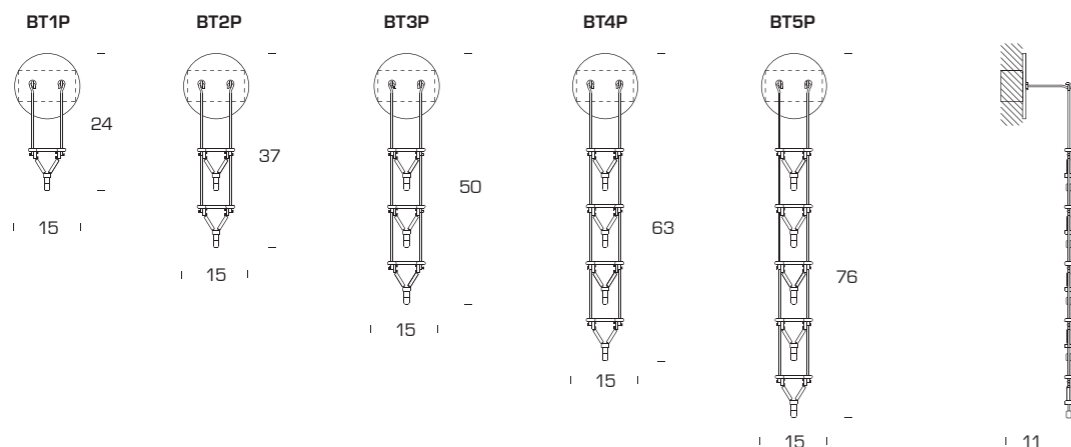

Simple White

Archivio Storico 1994





Lampada da parete.
Montatura in metallo
verniciato bianco.
Diffusore in vetro curvato
bianco opale (VBI) o
stampato (VST).

Wall lamp. White-painted
metal frame. Diffuser in
opal white (VBI) or
pressed curved glass
(VST).

Applique. Monture en
métal verni blanc.
Diffuseur en verre bombé
couleur blanc opale
(VBI) ou pressé (VST).

Wandlampe. Gestell aus
weiß lackiertem Metall.
Schirm aus gebogenem
weißem Opal- (VBI) oder
Pressglas (VST).

Lámpara de pared.
Estructura de metal
pintado blanco. Difusor
de cristal curvado blanco
mate (VBI) o grabado
(VST).

3027.. VBI - VST	36 x 8 x 40		1x36W (FL) 2G10
3028.. VBI - VST	16 x 4 x 29		1x11W (FL) 2G23

CE 3027.. IP40 3028.. IP20

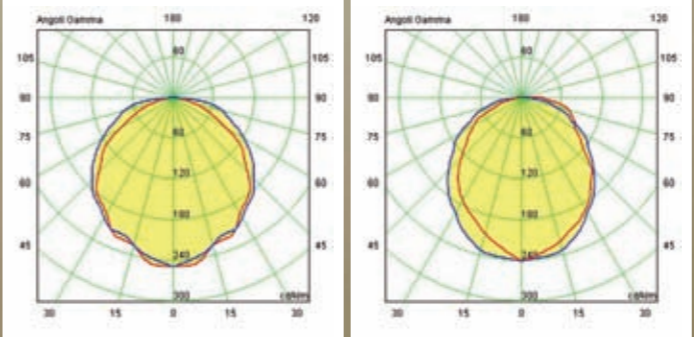
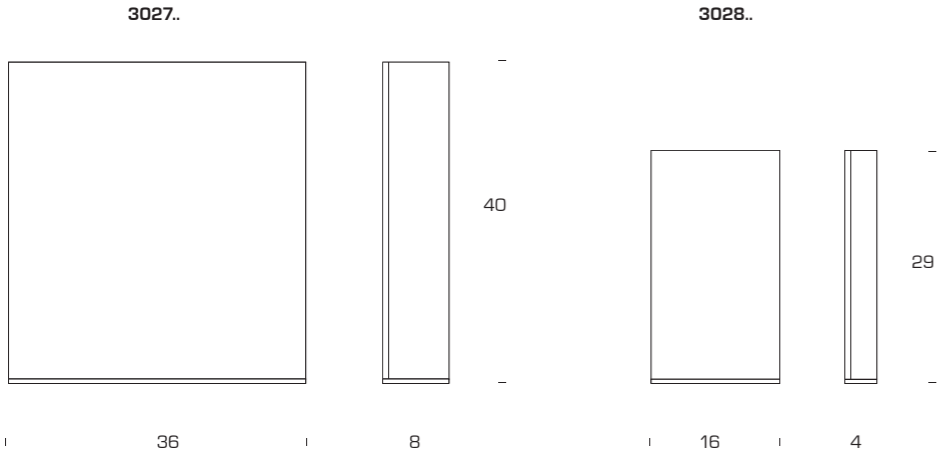

3027..

3028..

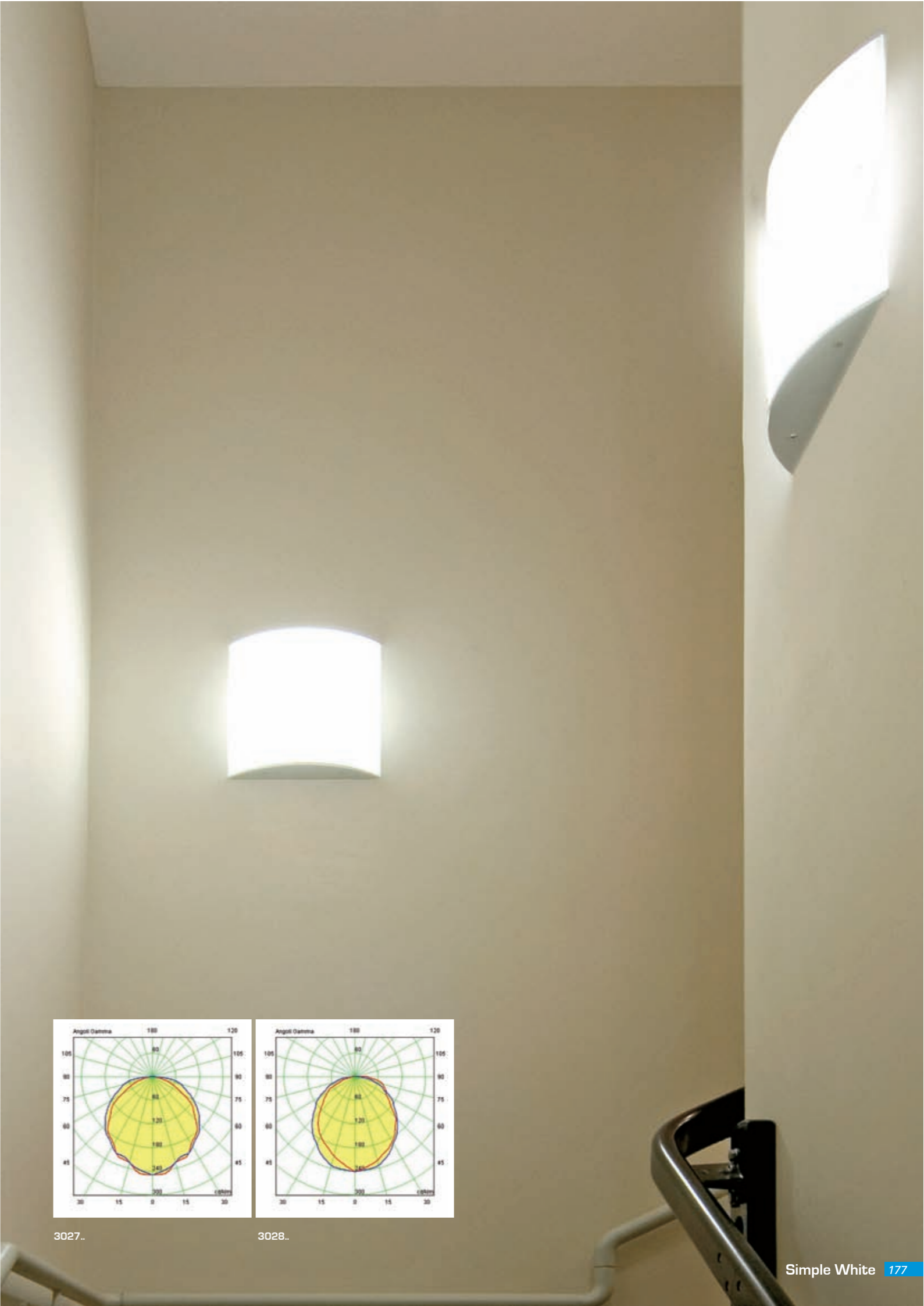

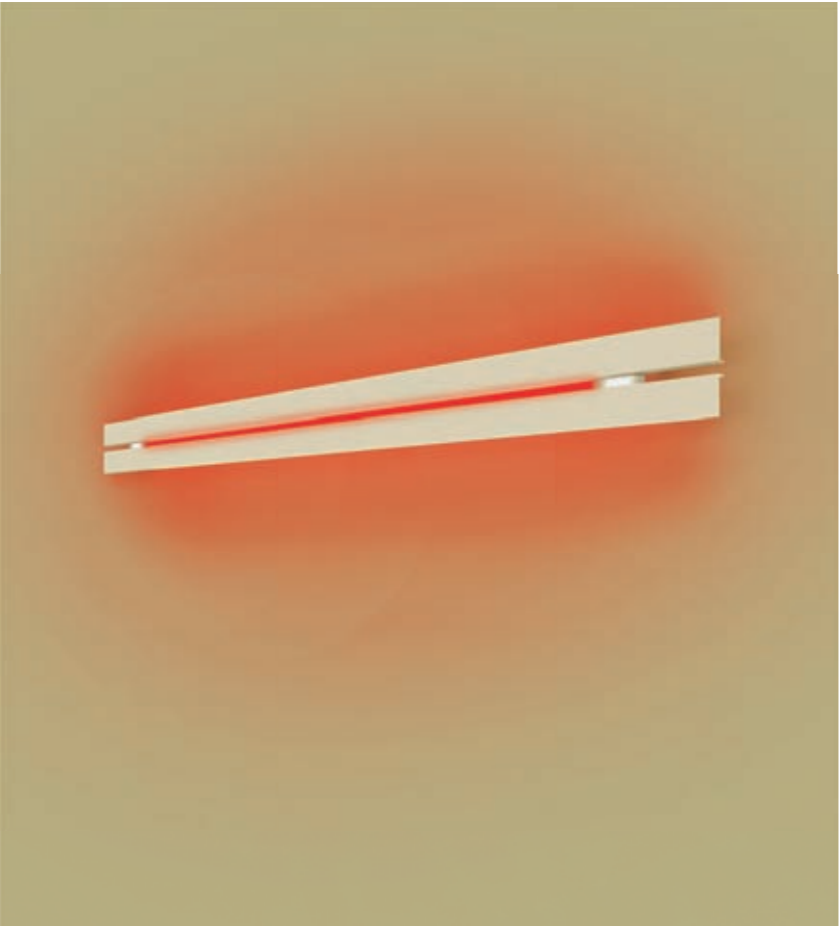

Lampada da parete.
Montatura in acciaio
verniciato lucido bianco.
Diffusori in vetro
temperato e sabbato.
L'effetto luminoso
colorato è dato dalla
sorgente luminosa.

Wall lamp. Mounting in
white polished painted
steel. Diffusers in
tempered and
sandblasted glass.
The coloured lighting
effect is produced by the
lighting source.

Applique. Monture en
acier verni blanc poli.
Diffuseurs en verre
trempé et sablé.
L'effet lumineux coloré
est produit par la source
d'éclairage.

Wandleuchte. Gestell aus
weißem glänzendem
lackiertem Stahl. Schirme
aus mattem Hartglas.
Der leuchtende Farbeffekt
ist auf das Leuchtmittel
zurück zu führen.

Lámpara de pared.
Montura de acero pintado
blanco brillante. Difusores
en vidrio templado y
arenado. El efecto de
iluminación de colores es
producido por la fuente
luminosa.

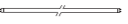
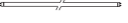
4121BI	74 x 10 x 8		1x14/24W (FL) G5
4121/1BI	104 x 10 x 8		1x39W (FL) G5
4121/2BI	134 x 10 x 8		1x54W (FL) G5

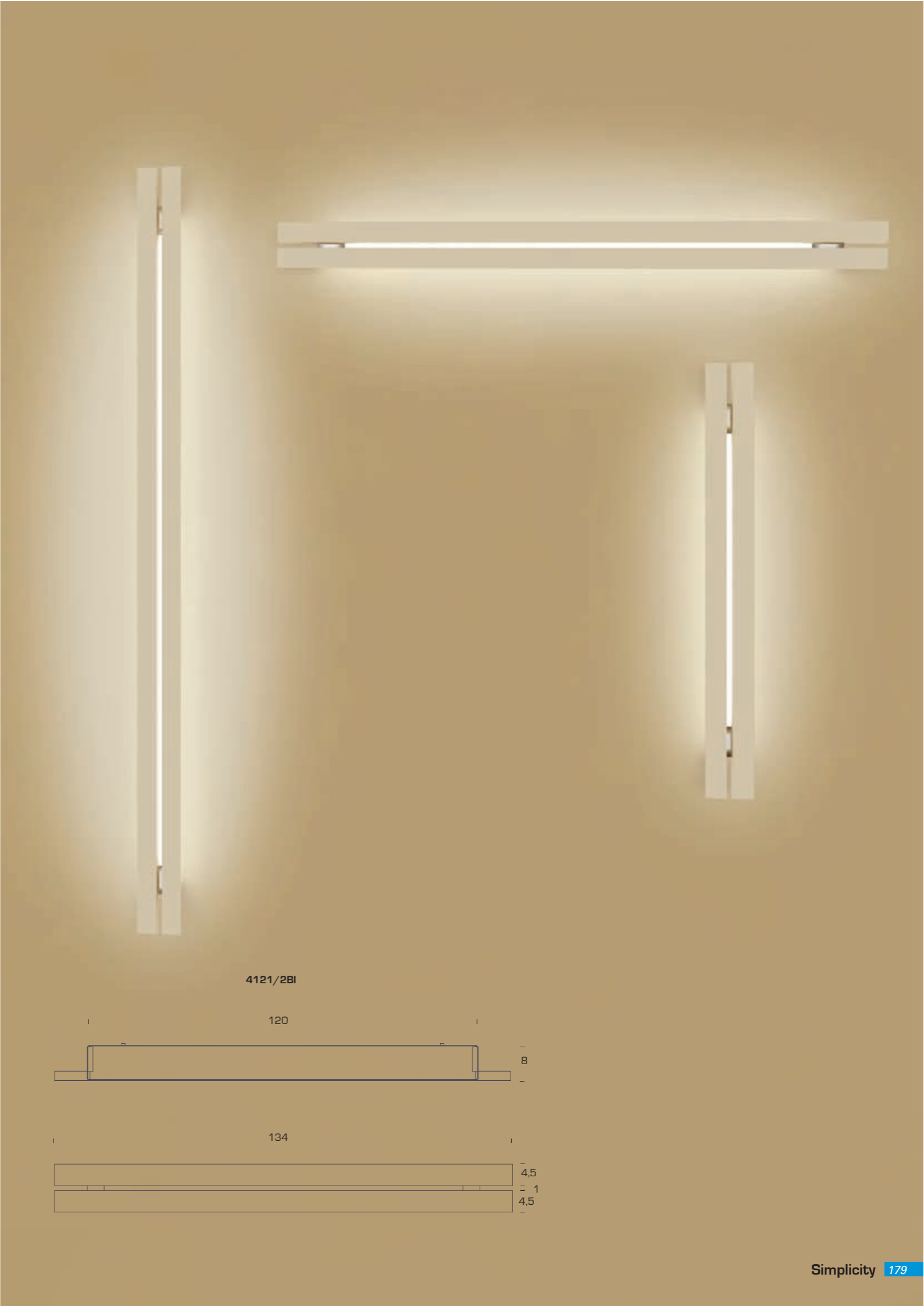
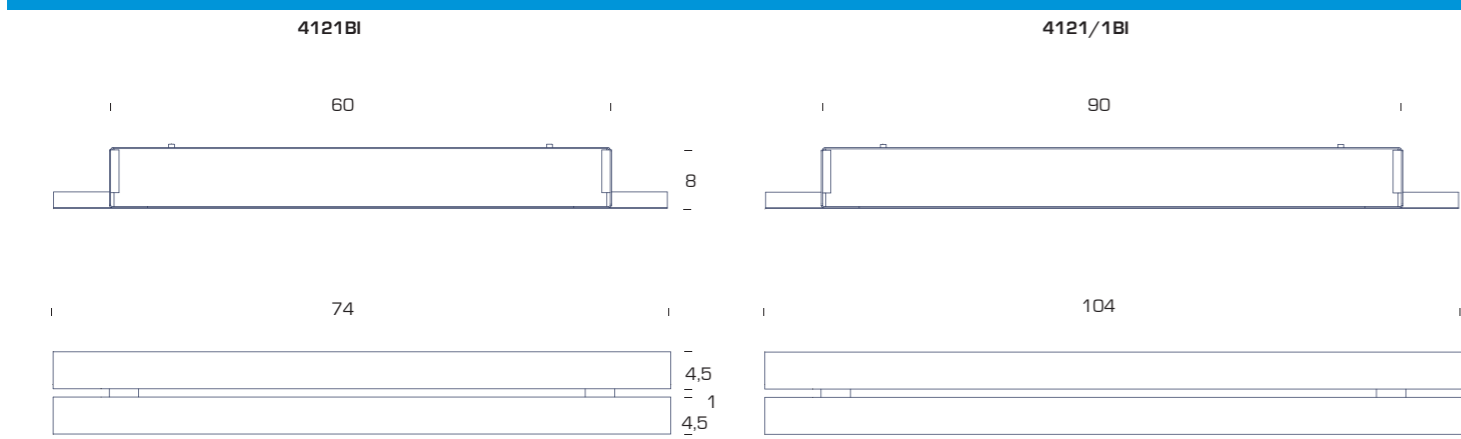

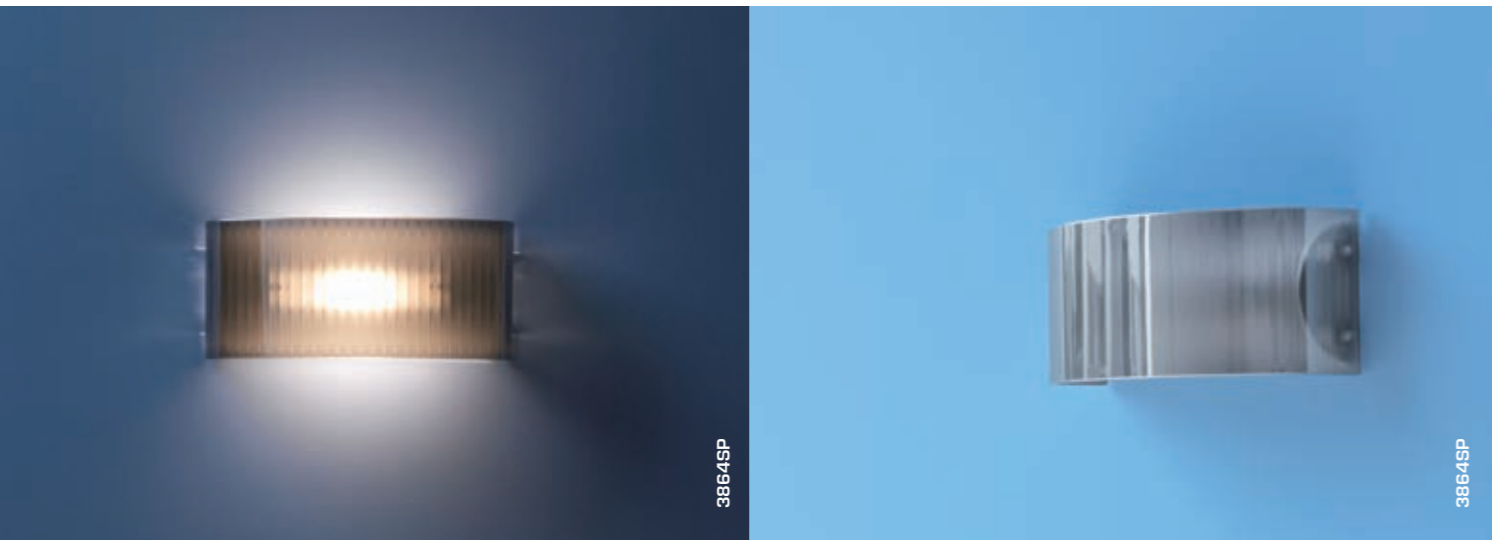

3864SP

3864SP



3864BI



Lampada da parete. Diffusore in vetro inciso curvato e acidato (BI) o metallizzato (SP). Tubo in vetro borosilicato a protezione della sorgente luminosa. Struttura in metallo verniciato a polvere bianca. L'apparecchio con finitura metallizzata presenta una finitura a specchio quando è spento, quando è acceso, invece, la luce passa attraverso il diffusore per una illuminazione diffusa e leggera.

Wall lamp. Diffuser in curved acid-etched (BI) or metallised (SP) glass. Tube in borosilicate glass for the protection of the lighting source. Structure in metal, painted with white powder. The appliance with metallised finishing, when switched off, seems to be a mirror, when switched on the light passes through for a diffused light emission.

Applique. Diffuseur en verre gravé traité avec l'acide (BI) ou métallisé. Tube protecteur de la source lumineuse en verre borosilicate. Structure en métal verni à la poudre blanche. L'appareil métallisé présente une finition à miroir lorsqu'il est éteint; quand il est allumé, la lumière passe à travers le diffuseur créant ainsi un éclairage diffus et léger.

Wandleuchte. Streukörper aus eingraviertem Glas, erhältlich geätzt (BI) oder metallisiert (SP). Schutzrohr aus Borosilikatglas. Struktur aus weißem pulverlackiertem Metall. Die metallisierte Leuchte, im ausgeschalteten Zustand, entsteht ein Spiegeleffekt; im angeschalteten Zustand, geht das Licht durch den Streukörper und so entsteht ein leichtes und diffuses Licht.

Lámpara de pared. Difusor de cristal grabado al ácido (BI) o metalizado (SP). Tubo de vidrio borosilicato a protección de la fuente luminosa. Estructura de metal pintado en polvo blanco. L'aparecto metalizado parece un espejo cuando está apagado; cuando está encendido, la luz rezuma a través de el difusor y una emisión de luz difusa es obtenida.

3864.. BI - SP 27 x 12 x 12  1x120W (HA)  R7s/115

  IP20

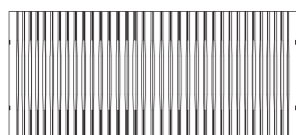

27

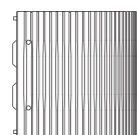

12

12







Lampada da parete.
Montatura in metallo
verniciato a polvere.
Diffusore in vetro soffiato
bianco opale.

Wall lamp. Powder-
painted metal frame. Opal
white blown glass diffuser.

Applique. Monture en
métal peint par poudrage.
Diffuseur en verre soufflé
couleur blanc opale.

Wandlampe. Gestell aus
pulver-lackiertem Metall.
Schirm aus weißem,
geblasenem Mattglas.

Lámpara de pared.
Estructura de metal
pintado con polvo. Difusor
de cristal soplado blanco
mate.

3296/0	11 x 20 x 33	 	1x40W (IN) o/or 1x8W (FL) E14
3296	13 x 25 x 39	 	1x60W (IN) o/or 1x16W (FL) E27

  IP20

3296/0

3296

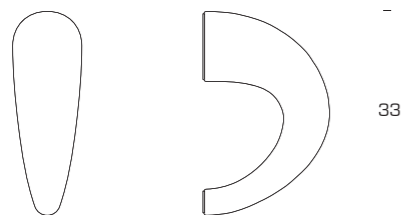

| 11 | | 20 | | 33 |

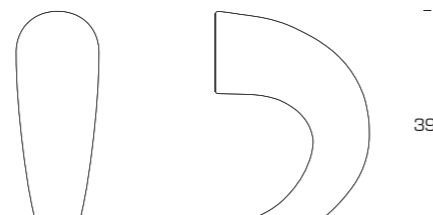

| 13 | | 25 | | 39 |



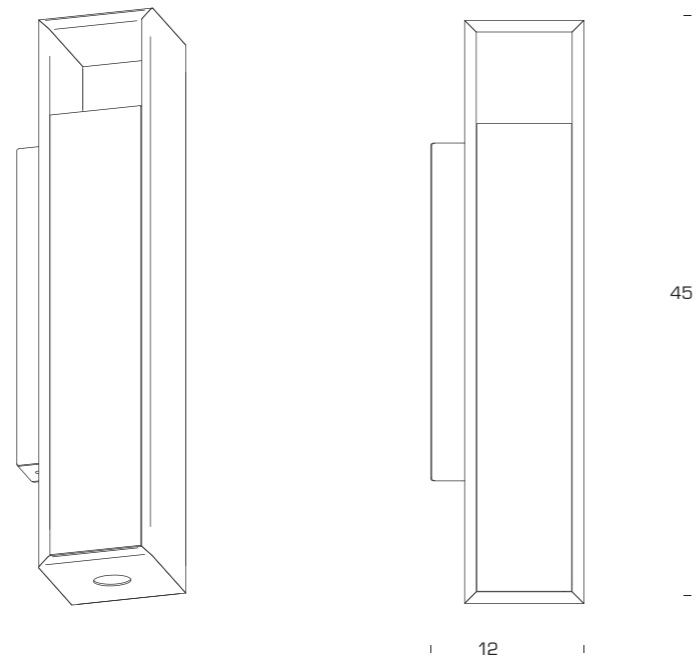

Lampada da parete.
Struttura in alluminio estruso anodizzato satinato (A) o anodizzato nero opaco (N). Diffusori in vetro bianco satinato (BI) o arancione ambra satinato (AM). Doppia emissione di luce: diffusa fluorescente e puntuale alogena. Trasformatori inclusi.

Wall lamp. Structure in anodised satin-finish extruded aluminium (A) or anodized matt black (N). Shades in white satin-finish glass (BI) or amber/orange satin-finish (AM). Double light emission: diffused fluorescent and concentrated halogen. Transformers included.

Applique. Structure en aluminium extrudé anodisé satiné (A) ou anodisé noir opaque (N). Diffuseurs en verre blanc satiné (BI) ou orange/ambre satiné (AM). Emission lumineuse double : diffuse fluorescent et concentré halogène. Transformateurs incluse.

Wandleuchte. Struktur aus Aluminium, stranggepresst, eloxiert, satiniert (A) oder eloxiert mattschwarz (N). Schirme aus weißem satiniertem (BI) oder bernsteinfarbenen satiniertem (AM) Glas. Doppelte Lichtverteilung: diffuse (Leuchstofflampe) und konzentrierte (Halogenlampe). Trafo werden mitgeliefert.

Lámpara de pared. Estructura de aluminio extrudido anodizado satinado (A) o anodizado negro opaco (N). Difusores de cristal blanco satinado (BI) o anaranjado/ámbar satinado (AM). Emisión de luz doble: difusa fluorescente y concentrada halogena. Transformadores incluidos.

Modello comunitario depositato

Design patent pending

Modèle communautaire déposé

Eingetragenes Warenzeichen

Modelo comunitario depositado

M5581.. A - N
struttura

M5581.. A - N
structure

M5581.. A - N
structure

M5581.. A - N
Struktur

M5581.. A - N
estructura

V5528.. AM - BI
diffusore

V5528.. AM - BI
shades

V5528.. AM - BI
diffuseurs

V5528.. AM - BI
Schirme

V5528.. AM - BI
difusores

M5581.. A - N + V5528.. AM - BI 12 x 45  1x18W (IN) 2G11 + 1x20W (HA)  GU4

   Classe II IP20



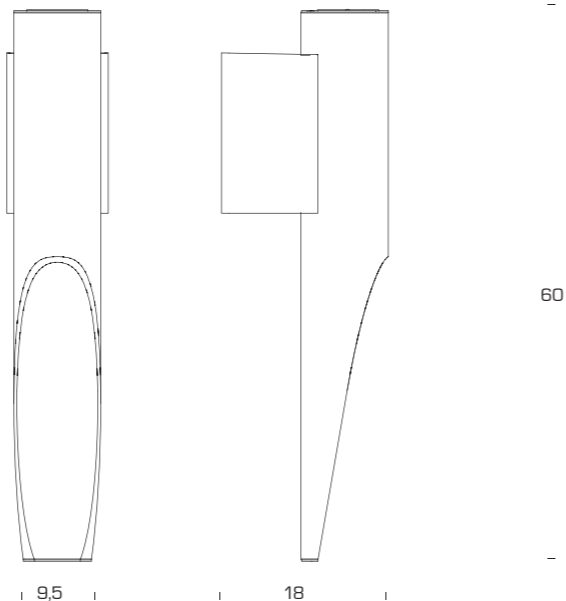

60

Lampada da parete. Doppia emissione luminosa, diretta e indiretta. Accensione separata. Corpo in alluminio, disponibile nelle seguenti finiture di colore: bianco testurizzato internamente e esternamente (BI/BI), cromato esternamente e verniciato arancio lucido internamente (CR/AR), cromato esternamente e verniciato bianco lucido internamente (CR/BI). Per l'emissione diretta verso il basso è possibile utilizzare sorgenti luminose a Led, disponibili come accessori nei seguenti colori: bianco (BI), blu (BL), giallo ambra (GI), rosso (R), verde (V). Il diffusore superiore può essere rimosso per un'illuminazione indiretta più diffusa.

Wall lamp. Double light emission, direct and indirect. Separate switch. Body in aluminium. Available in the following finishing: texturized white on the inside and on the outside (BI/BI), chrome-plated on the outside and polished painted orange the inside (CR/AR), chrome-plated on the outside and polished white on the inside (CR/BI). For direct light emission downwards it is possible to use Led lighting sources, available as an accessory in the following colours: white (BI), blue (BL), yellow amber (GI), red (R), green (V). The upper diffuser may be removed for a more diffused indirect light emission.

Applique. Double émission de lumière, directe et indirecte. Allumage séparé. Corps en aluminium, disponible blanc texturisé intérieurement et extérieurement (BI/BI), chromé à l'extérieur et orange à l'intérieur (CR/AR), chromé à l'extérieur et blanc à l'intérieur (CR/BI). Pour l'émission directe vers le bas il est possible d'utiliser des Led, disponibles comme accessoires dans les couleurs suivantes: blanc (BI), bleu (BL), jaune ambre (GI), rouge (R), vert (V). Possibilité d'enlever le diffuseur supérieur pour une illumination indirecte plus douce.

Wandlampe. Doppelte Lichtausstrahlung: direkt und indirekt. Getrennte Einschaltung. Körper aus Aluminium. In folgenden Ausführungen erhältlich: innen und außen texturisiert (BI/BI), außen verchromt und innen orangefarben (CR/AR), außen verchromt und innen weiß glänzend (CR/BI). Für die direkte Ausstrahlung nach unten ist es möglich, Led Lichtquellen verwenden. Die sind als Zubehör in den folgenden Farben verfügbar: weiß (BI), blau (BL); Bernstein gelb (GI), rot (R), grün (V). Für eine indirekte Lichtverteilung kann der obere Schirm entfernt werden.

Lámpara de pared. Doble emisión luminosa, directa e indirecta. Encendido separado. Cuerpo de aluminio, disponible con los siguientes acabados de color: blanco texturizado internamente y externamente (BI/BI), cromado externamente y pintado anaranjado pulido internamente (CR/AR), cromado externamente y pintado blanco pulido internamente (CR/BI). Para la emisión directa hacia abajo es posible utilizar fuentes luminosas de Led disponibles como accesorios con los siguientes colores: blanco (BI), azul (BL), amarillo ambar (GI), rojo (R) y verde (V). El difusor superior se puede remover para obtener una emisión indirecta más difusa.

Modello comunitario depositato

Design patent pending

Modèle communautaire déposé

Eingetragenes Warenzeichen

Modelo comunitario depositado

L1GU10.. BI - BL - GI - R - V
lampadina Led colorata
1,5W GU10 15°

L1GU10.. BI - BL - GI - R - V
coloured Led bulb
1,5W GU10 15°

L1GU10.. BI - BL - GI - R - V
ampoule Led colorée 1,5W
GU10 15°

L1GU10.. BI - BL - GI - R - V
farbige Led - Lampe
1,5W GU10 15°

L1GU10.. BI - BL - GI - R - V
bombilla Led colorada
1,5W GU10 15°

3868.. BI/BI - CR/AR - CR/BI ø 9,5 x 18 x 60 1x205W (HA) (ES) B15d+1x75W GU-GZ10* (HA) or (Led)

CE IP20

* 1x75W sostituibile con / replaceable by / substituable par / ersatzlich mit / sostituibile con 1x1,5W GU10 (Led)

3868CR/AR + L1GU10BI

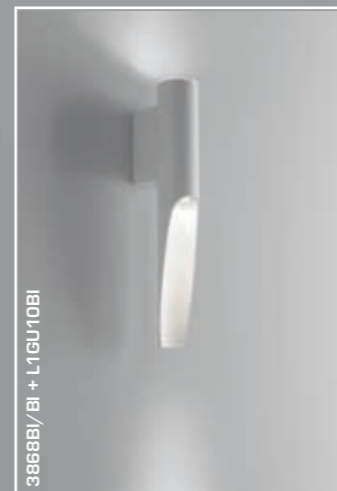

3868BI/BI + L1GU10BI



3868BI/BI + L1GU10V

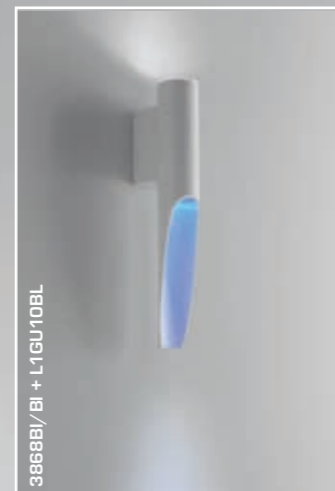

3868BI/BI + L1GU10BL



3868BI/BI + L1GU10R

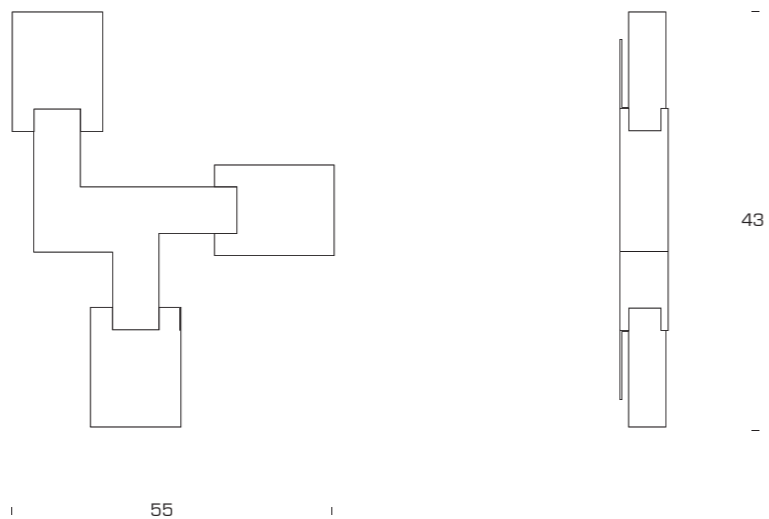

55

43

Lampada da parete.
Montatura in
pressofusione di alluminio
verniciato color grigio
alluminio. Diffusori in vetro
curvato bianco.

Wall lamp. Aluminium
grey-painted die-cast
aluminium frame. White,
curved glass diffusers.

Applique. Monture en
aluminium moulé sous
pression verni gris
aluminium. Diffuseurs en
verre bombé couleur
blanc.

Wandlampe. Gestell aus
aluminiumgrau lackiertem
Aluminiumpressguss.
Schirme aus gebogenem
weißem Glas.

Lámpara de pared.
Estructura de aluminio
moldeada bajo presión
pintado color gris
aluminio. Difusor de
cristal curvado blanco.

3332 55 x 6 x 43 3x60W (IN) o/or 3x42W (HA) E14

CE IP20

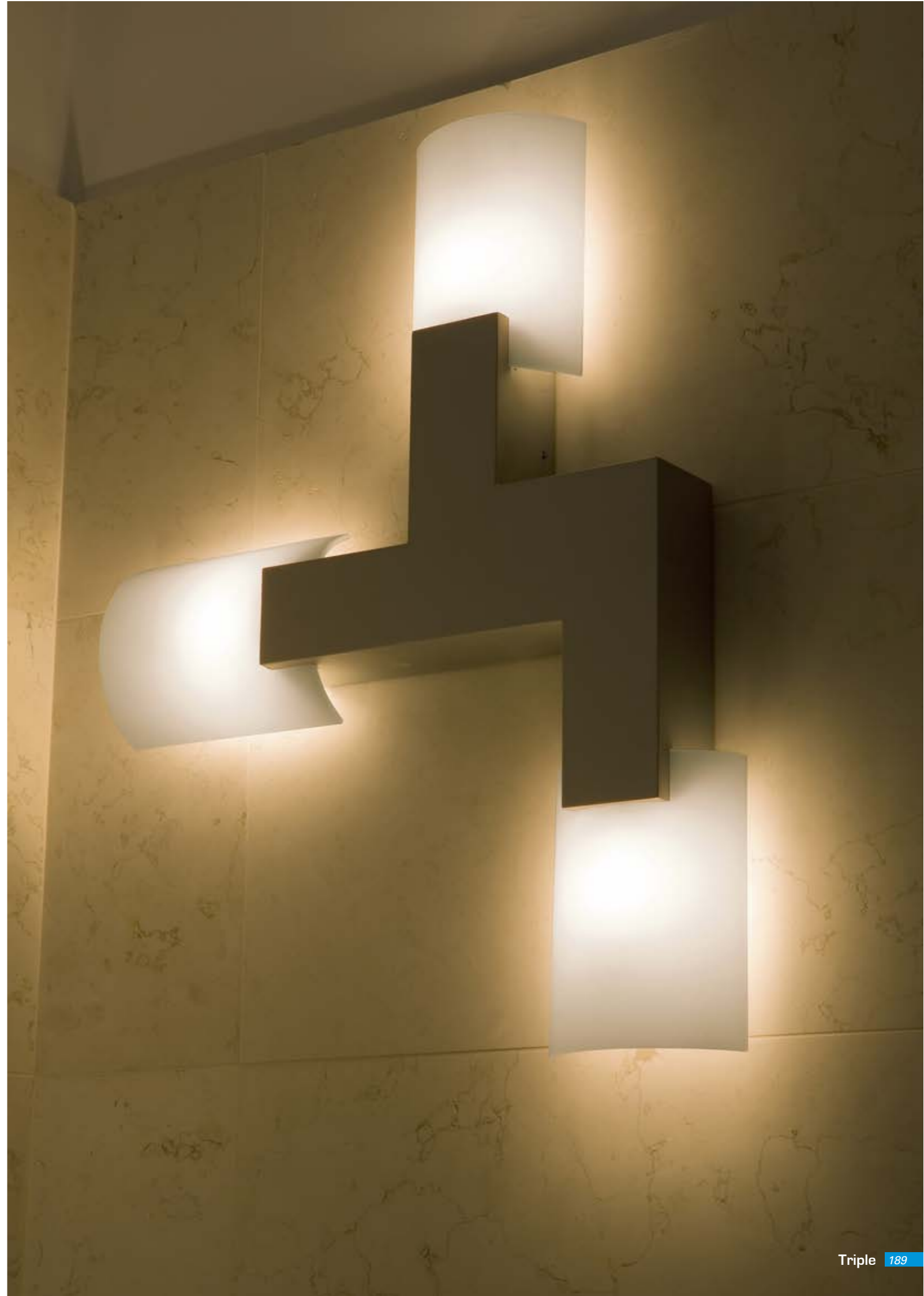

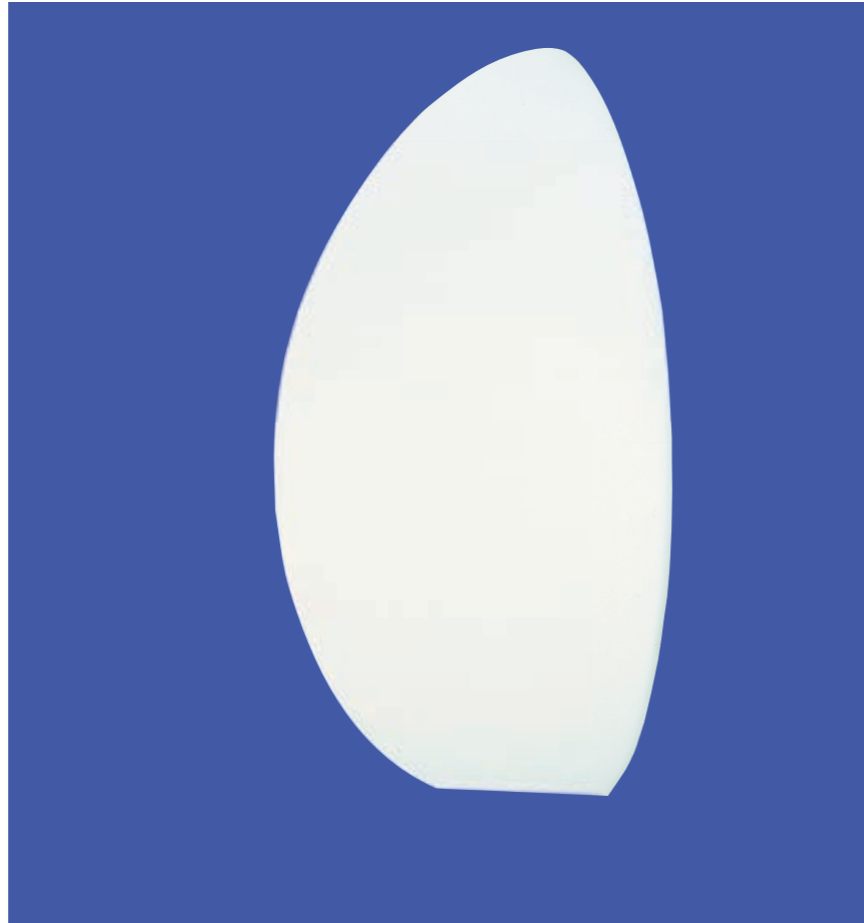

Lampada da parete.
Montatura in acciaio
verniciato bianco.
Diffusore in vetro soffiato
bianco opalino.

Wall lamp. White painted
mounting. Diffuser in
white opal blown glass.

Applique. Structure vernie
blanc. Diffuseur en
verre soufflé blanc opalin.

Wandlampe. Weiß
lackiertem Struktur.
Schirm aus weißem
mundgeblasem Opalglas.

Lámpara de pared.
Montura de acero
barnizado blanco. Difusor
de cristal soplado blanco
opalino.

3633/0	17 x 8 x 26		1x60W [HA] (ES) G9
3633/1	26 x 13 x 40		1x75W [IN] o/or 1x70W [HA] (ES) E27
3633	42 x 21 x 59		1x100W [HA] (ES) E27

IP20

3633/0

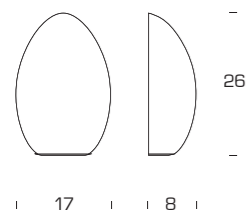

3633/1

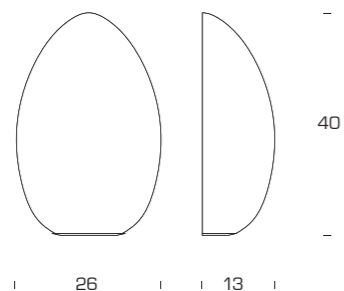

3633

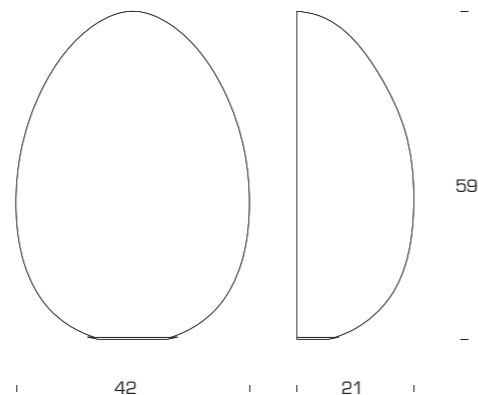

2805/0

2805

2805/1

2805/2

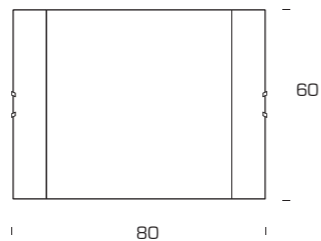
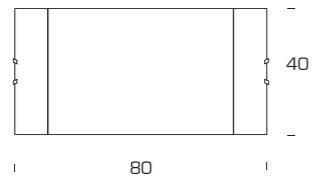
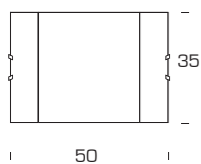

Lampada da parete.
Montatura con porta lampada e riflettore in alluminio brillantato. Diffusore in vetro curvato (spessore 3 mm) indurito e sabbiato. Schermo di protezione per lampadina alogena in vetro borosilicato sabbiato.

Wall lamp. Frame with lamp holder and reflector in polished aluminium. Diffuser in tempered, sandblasted, curved glass (3 mm thick). Halogen bulb protective pipe in sandblasted borosilicate glass.

Applique. Monture avec douille et réflecteur en aluminium brillanté. Diffuseur en verre bombé (épaisseur 3 mm) durci et sablé. Tube de protection pour ampoule halogène en verre borosilicate sablé.

Wandlampe. Gestell mit Lampenfassung und Reflektor in poliertem Aluminium. Schirm aus gebogenem, gehärtetem und sandgestrahltem Glas, (Stärke 3 mm). Scheiben für Halogenlampe aus sandgestrahltem Borosilikatglas.

Aplique de pared. Estructura con portabombilla y reflector de aluminio brillante. Difusor de cristal curvado (de 3 mm de espesor), endurecido y arenado. Tubito de protección para bombilla halógena de vidrio borosilicato arenado.

2805/0	50 x 35 x 12		1x160W (HA) (ES) R7s/115
2805	80 x 40 x 11		1x160W (HA) (ES) R7s/115
2805/1	80 x 60 x 11,5		1x160W (HA) (ES) R7s/115
2805/2	120 x 60 x 9,5		1x160W (HA) (ES) R7s/115

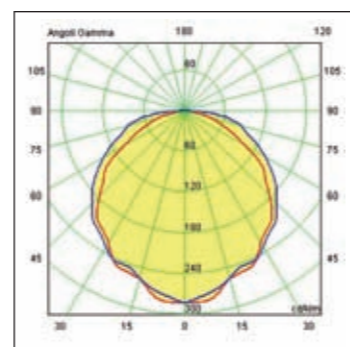



Lampada da parete. Emissione di luce indiretta. Struttura in pressofusione di alluminio verniciata colore bianco (BI) oppure spazzolata (NS). Protezione per lampadina alogena in vetro borosilicato sabbato.

Wall lamp. Indirect light emission. Structure in die cast aluminium, available white painted (BI) or brushed (NS). Safety screen for halogen bulb in sandblasted borosilicate glass.

Applique. Emission de lumière indirecte. Monture en aluminium moulé sous pression, disponible blanc (BI) ou brossé poli (NS). Protection pour ampoule halogène en verre borosilicate sablé.

Wandleuchte. Indirekte Beleuchtung. Körper aus weiß lackiertem (BI) oder gebürstetem (NS) Aluminium-Druckguss. Der integrierte Reflektor wird von einem sandmattiertem Diffusor aus Borosilikatglas abgeschlossen.

Aplique de pared. Emission de luz indirecta. Estructura de aluminio moldeada bajo presión, disponible pintada blanca (BI) o cepillada brillante (NS). Protección para bombilla halógena de vidrio borosilicato arenado.

Modello comunitario depositato

Design patent pending

Modèle communautaire déposé

Eingetragenes Warenzeichen

Modelo comunitario depositado

A4049.. BI - NS
piattello

A4049.. BI - NS
plate

A4049.. BI - NS
plateau

A4049.. BI - NS
Abdeckteller

A4049.. BI - NS
platillo

4049.. BI - NS 31 x 7 x 18  1x230W (HA)  R7s/115

   

4049..

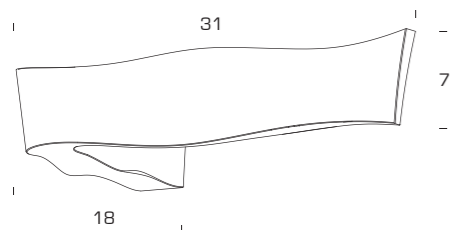

A4049..

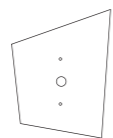

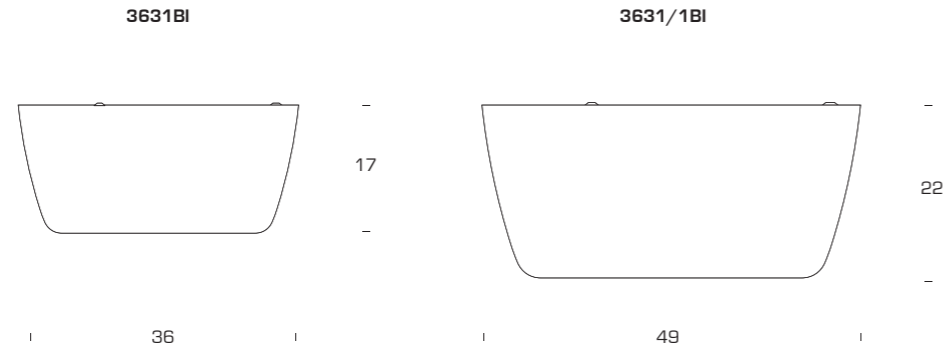





Lampada a plafone a doppia accensione. Montatura in metallo verniciato bianco. Diffusore in vetro soffiato bianco opalino acidato.

Ceiling lamp with double switching. White painted metal mounting. Diffuser in white opal acid-etched blown glass.

Plafonnier. Possibilité de double allumage. Structure en métal verni blanc. Diffuseur en verre soufflé blanc opalin traité avec l'acide.

Deckenlampe mit Möglichkeit der Doppelschaltung. Struktur aus weißem lackiertem Metall. Schirm aus weißem, geätztem mundgeblasem Opalglas.

Lámpara de plafón con posibilidad de doble encendido. Montura en metal pintado blanco. Difusor de cristal soplado blanco opalino tratado al acido.

3631BI	∅ 36 x 17	 	1x20W (FL) E27+1x22W (FL) 2GX13
3631/1BI	∅ 49 X 22	 	1x20W (FL) E27+1x55W (FL) 2GX13



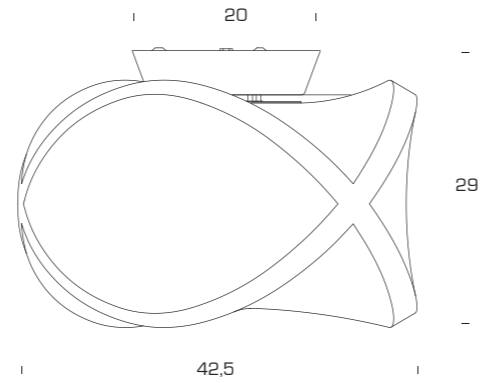

Lampada a plafone.
Diffusore in vetro soffiato
opalino bianco acidato.
Montatura in metallo
verniciato bianco.

Ceiling lamp. White acid-
etched opal blown glass
diffuser. Mounting in
white painted metal.

Plafonnier. Diffuseur
en verre soufflé blanc
opalin traité avec l'acide.
Base en métal verni blanc.

Deckenleuchte. Weißer
Leuchtschirm aus
geätztem Opalglas.
Deckenbefestigung aus
weiß lackiertem Metall.

Lámpara de plafón.
Difusor de cristal soplado
blanco opalino al ácido.
Montura de metal pintado
blanco.

3650BI ø 42,5 x 29 1x150W (HA)  E27

     IP20



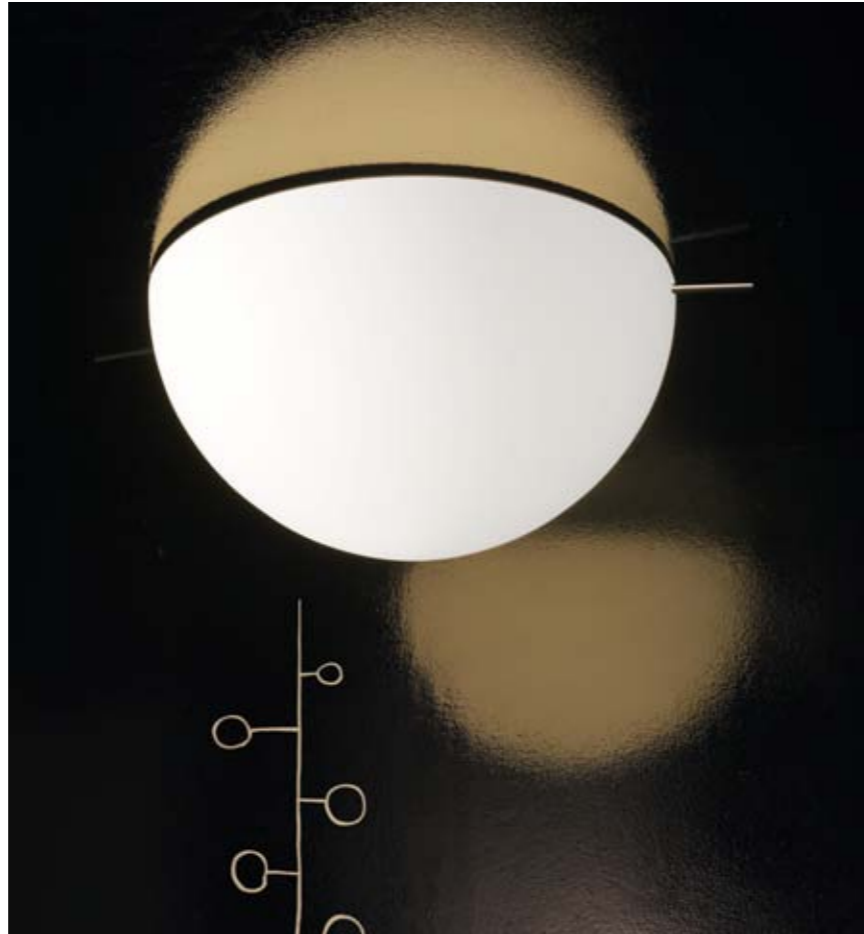

Lampada da parete /
plafone. Diffusore in vetro
soffiato bianco opalino
satinato. Puntali cilindrici
per il blocco dei diffusori
in metallo cromato.
Montatura in metallo
verniciato bianco.

Wall/ceiling lamp.
Diffuser made of opal
white blown glass with
satin finish. Cylindrical
chrome-plated handgrip
for the fixing of the
diffusers. Mounting in
white painted metal.

Applique pour mur /
plafond. Diffuseur en
verre soufflé blanc opalin
satiné. Embouts
cylindriques pour bloquer
les diffuseurs en métal
chromé. Monture en
métal verni blanc.

Wand- und Deckenleuchte
mit Streukörper aus
Opalglas, weiß-satiniert.
Zylindrische verchromte
Metallspitzen zur
Befestigung der
Streukörper. Gestell aus
weißem lackierten Metall.

Lámpara para pared /
plafón. Difusor de vidrio
soplado blanco opalino
satinado. Extremidades
cilíndricas para el bloqueo
de los difusores de metal
cromado. Armadura de
metal pintado blanco.

4031BI	∅ 25 x 13		1x100W (HA) (ES) o/or 1x20W (FL) E27
4031/1BI	∅ 50 x 25,5		1x55W 2GX13 (FL)

IP20

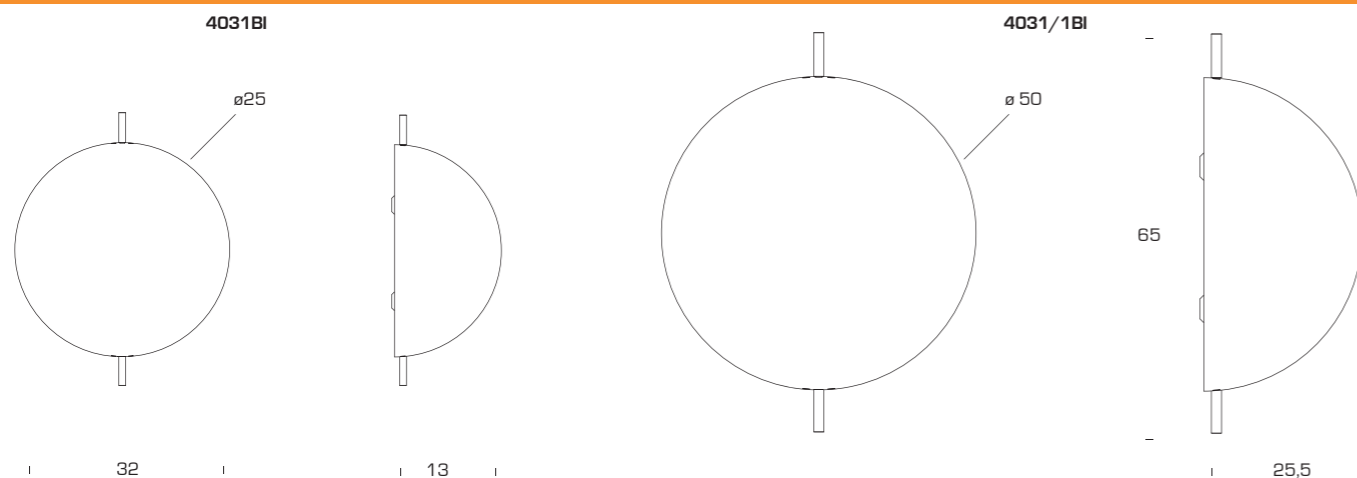

Piccolo Teatro, Milano

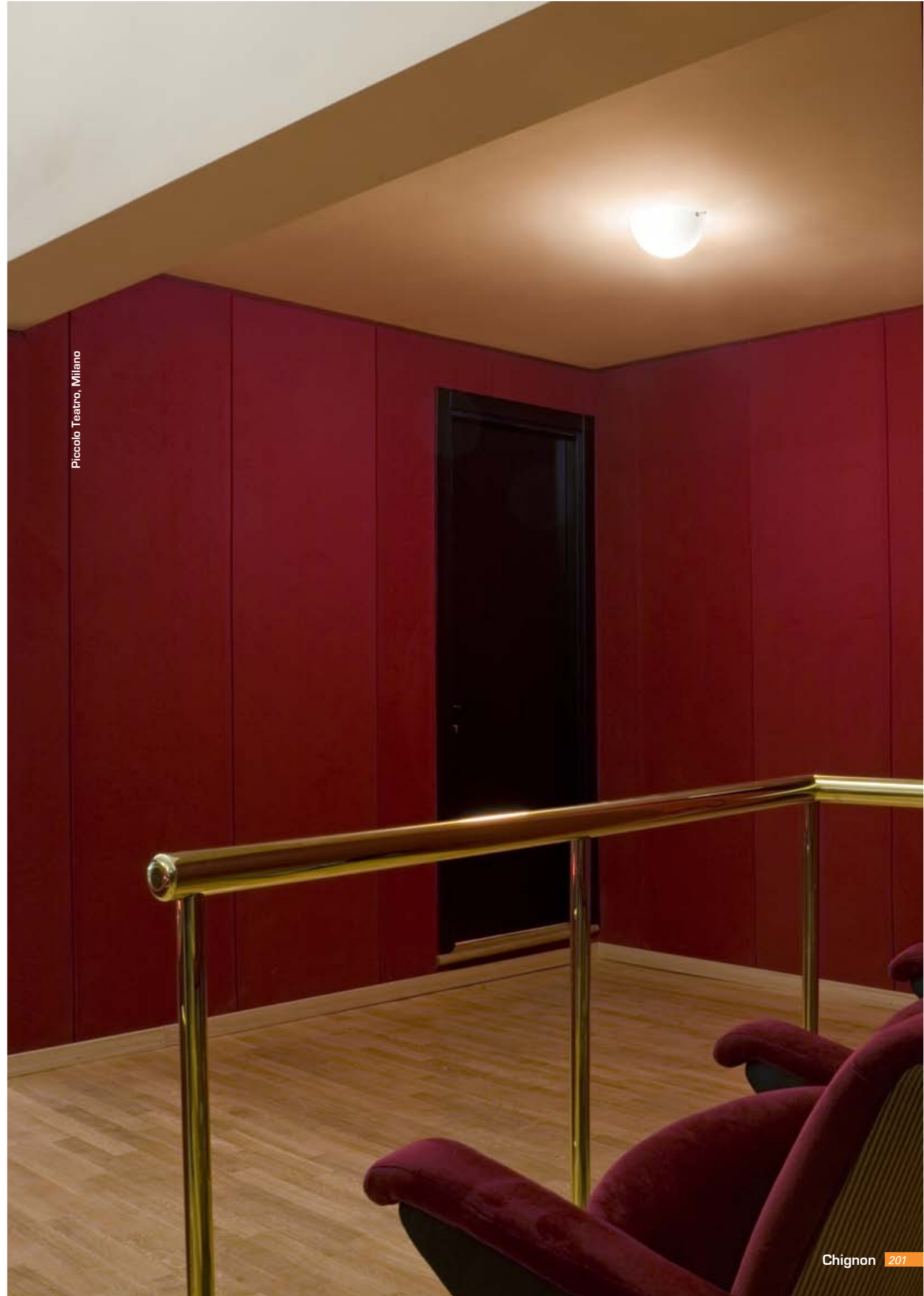

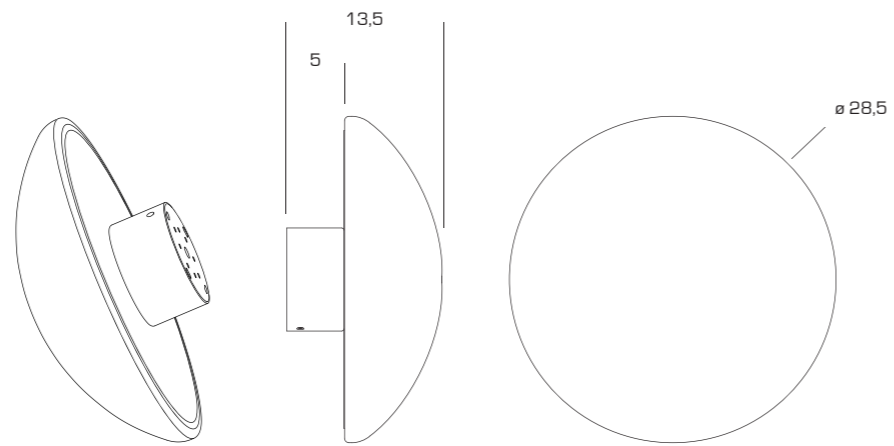

Lampada da parete /
plafone. Montatura e
riflettore in metallo
cromato. Alimentatore
elettronico incluso.

Wall / ceiling lamp.
Mounting and reflector in
chrome-plated metal.
Electronic ballast included.

Applique murale /
plafonnier. Structure et
diffuserus en métal
chromé. Alimentateur
électronique inclus.

Wand- / Deckenleuchte.
Gestell und Schirm aus
verchromtem Metall.
Elektronisches Vorschalt-
gerät inbegriffen.

Lámpara de pared /
plafón. Estructura y
difusor en metal cromado.
Alimentador electrónico
incluido.

4016CR ø 28,5 x 13,5 ○ 1x22W (FL) 2GX13

   IP20





Lampada a plafone.
Diffusore in vetro soffiato
bianco satinato.
Montatura in metallo
cromato. Di facile
manutenzione, è
disponibile in due
dimensioni e con sorgente
luminosa fluorescente o
alogeno.

Ceiling lamp. Diffuser
in blown white satin
glass. Mounting in
chrome-plated metal.
Of easy maintenance,
it is available in two
dimensions and with
fluorescent or halogen
light source.

Plafonnier. Diffuseur en
verre soufflé blanc satiné.
Monture en métal
chromé. De manutention
facile, est disponible en
deux dimensions et avec
source lumineuse
fluorescente ou halogène.

Deckenleuchte. Schirm aus
weißen mundgeblasenem
satiertem Glas. Struktur
aus verchromten Metall.
Wartungsfreundlich,
ist sie erhältlich in zwei
Größen und mit
Leuchtstoff- und
Halogenlampe.

Lámpara de plafón.
Difusor de cristal soplado
blanco satinado.
Estructura de metal
cromado. De simple
manutención, está
disponible en dos
tamaños y con la fuente
luminosa fluorescente
o alogeno.

3833	∅ 40 x 14	○	1x22W (FL) 2GX13
3833/1	∅ 60 x 17	○	1x55W (FL) 2GX13
3834	∅ 40 x 14	⇒	3x40W (HA) o/or 3x33W (HA) (ES) G9
3834/1	∅ 60 x 17	⇒	3x60W (HA) (ES) G9

CE IP20

3833 - 3834

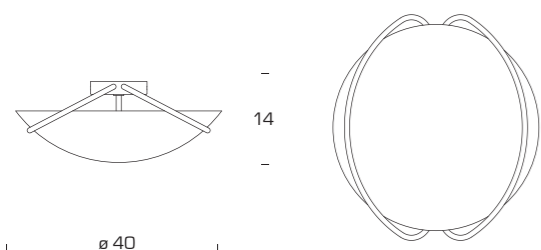

3833/1 - 3834/1

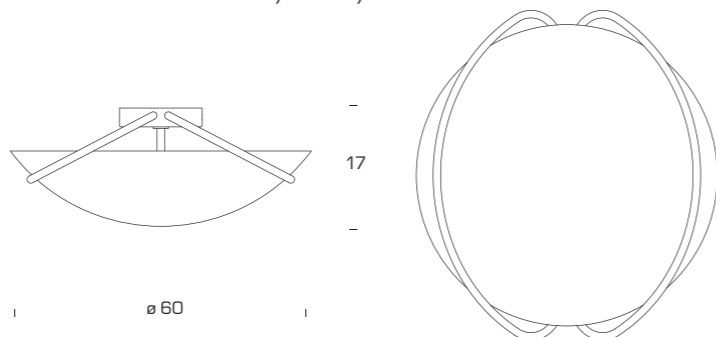

Lunapiena

Roberto Righetti 2003



Lampada da parete o plafone. Montatura in metallo verniciato bianco. Diffusore in polimetilmetacrilato.

Wall or ceiling lamp. White painted metal structure. Diffuser in polymethacrylate.

Applique ou plafonnier. Structure en métal verni blanc. Diffuseur en polyméthacrylate.

Wand- oder Deckenlampe. Struktur aus weißem lackiertem Metall. Schirm aus Polymethacrylat.

Lámpara de pared o plafón. Estructura de metal pintado blanco. Difusor de polimetilmetacrilato.



5383 ø 41 x 9 1x55W (FL) 2GX13

CE IP20

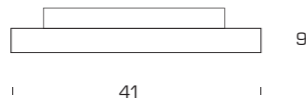
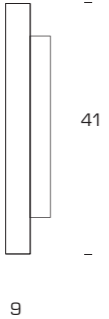
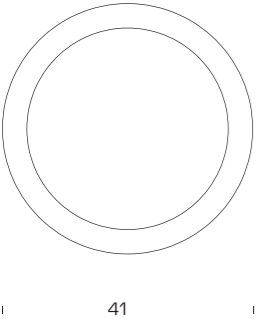



Teatro Civico, Tortona

Lampada da parete o plafone. Montatura in tecnopolimero a elevata resistenza termica. Diffusore in vetro sabbiato termoresistente.

Wall or ceiling lamp. Heat-resistant mounting in technopolymer. Diffuser made of high-resistant sandblasted glass.

Applique ou plafonnier. Monture en technopolymère à résistance thermique élevée. Diffuseur en verre sablé thermorésistant.

Wand-oder Deckenlampe. Gestell aus hoch hitzebeständigem Technopolymer. Schirm aus hitzebeständigem sandgestrahltem Glas.

Lámpara de pared o plafón. Montura en tecnopolimero de elevada resistencia térmica. Difusor de cristal arenado termoresistente.

2775/2G - 2775/5G - 2775/7G
bassa tensione

2775/2G - 2775/5G - 2775/7G
at low voltage

2775/2G - 2775/5G - 2775/7G
à bas voltage

2775/2G - 2775/5G - 2775/7G
für Niederspannung

2775/2G - 2775/5G - 2775/7G
de baja tensión

2775/7/23G
tensione di rete

2775/7/23G
at main voltage

2775/7/23G
à tension réseau

2775/7/23G
für Netzspannung

2775/7/23G
tensión de red

Lampada da incasso per parete o plafone a bassa tensione. Montatura in tecnopolimero a elevata resistenza termica. Diffusore in vetro sabbiato termoresistente.

Recessed lamp for wall and ceiling at low voltage. Mounting in high heat-resistant technopolymer. Shade in heat-resistant sandblasted glass.

Lampe à encastrer dans le mur ou au plafond, à bas voltage. Monture en technopolymère à résistance thermique élevée. Diffuseur en verre sablé thermorésistant.

Einbauleuchte für Wand und Decke für Niederspannung. Gestell aus hoch hitzebeständigem Technopolymer. Schirm aus hitzebeständigem sandgestrahltem Glas.

Lámpara empotrable para pared y plafón de tensión baja. Montura en tecnopolimero de elevada resistencia térmica. Difusor de cristal arenado termoresistente.

2969/2G - 2969/5G
bassa tensione

2969/2G - 2969/5G
at low voltage

2969/2G - 2969/5G
à bas voltage

2969/2G - 2969/5G
für Niederspannung

2969/2G - 2969/5G
de baja tensión

2775/2G	ø 9 x 6	⇒	1x20W (HA) o/or 1x14W (HA) (ES) G4 12V
2775/5G	ø 12 x 7	⇒	1x50W (HA) o/or 1x35W (HA) (ES) GY6.35 12V
2775/7G	ø 14 x 9	⇒	1x50W (HA) (ES) GY6.35 12V
2775/7/23G	ø 14 x 9	⇒	1x60W (HA) o/or 1x48W (HA) (ES) G9 230V

2969/2G	ø 9 x 6	⇒	1x20W (HA) o/or 1x14W (HA) (ES) G4 12V
2969/5G	ø 12 x 7	⇒	1x50W (HA) o/or 1x35W (HA) (ES) GY6.35 12V

2775/2G - 2775/5G - 2775/7/23G
 2775/7/23G IP44
 Classe # 2775/7G
 Classe # 2775/2G - 2775/5G - 2775/7G - 2969/2G - 2969/5G



2775/2G (12V)

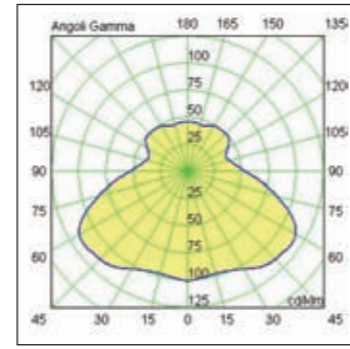
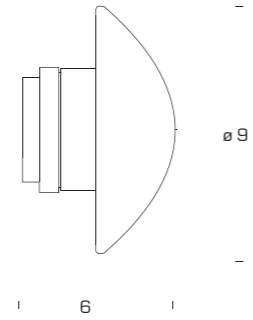
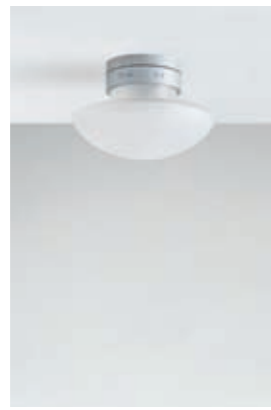

2775/2G /12V)

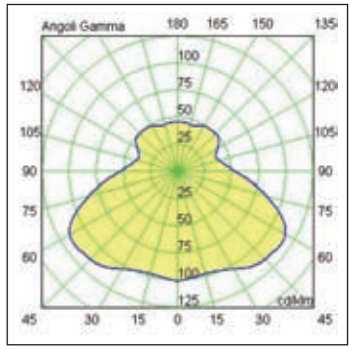
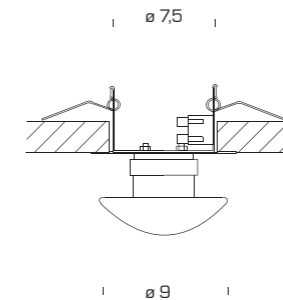

2775/5G (12V)

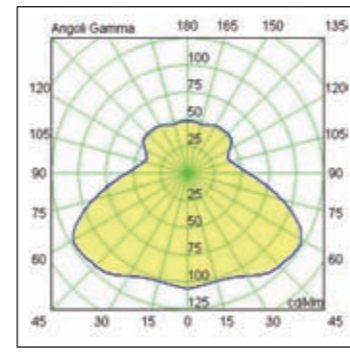
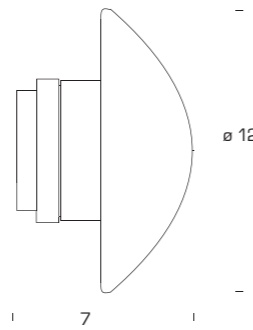

2775/5G (12V)

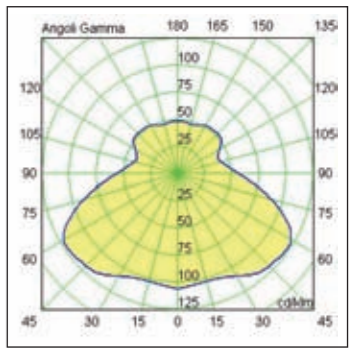
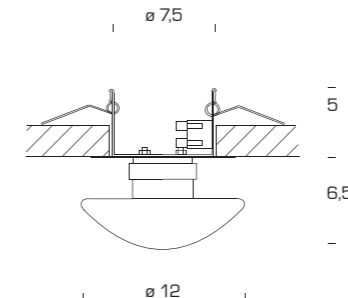

2775/7G (12V)

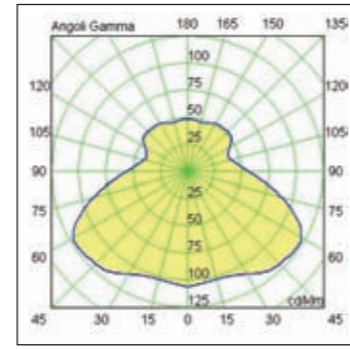
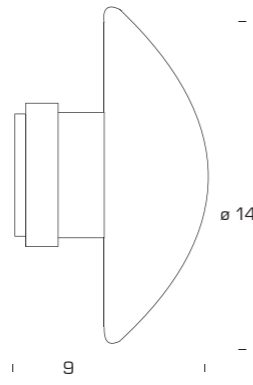

2775/7/23 G (230V)

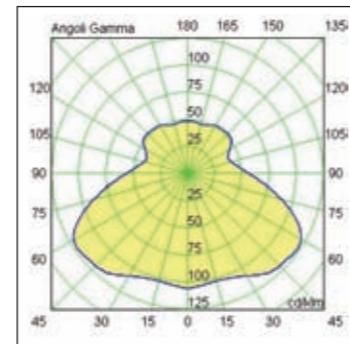
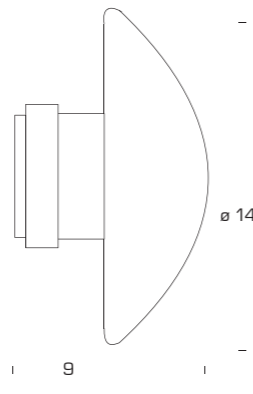

Sillabone

Piero Castiglioni 1988



Lampada da parete o
plafone. Montatura in
metallo verniciato grigio.
Diffusore in vetro sabbato
termoresistente.

Wall or ceiling lamp.
Grey painted metal
structure. Heat-resistant
sandblasted glass
diffuser.

Applique murale ou
plafonnier. Structure en
m tal verni gris. Diffuseur
en verre sabl 
thermor sistant.

Wand- oder Deckenlampe.
Struktur aus grauem
lackiertem Metall. Schirm
aus hitzebest ndigem
sandgestrahltem Glas.

L mpara de pared o
plaf n. Estructura en
metal barnizado
gris. Difusor en cristal
arenado
termorresistente.

2793G \varnothing 35 x 20 1x100W (HA) E27

CE ∇ UL IP20

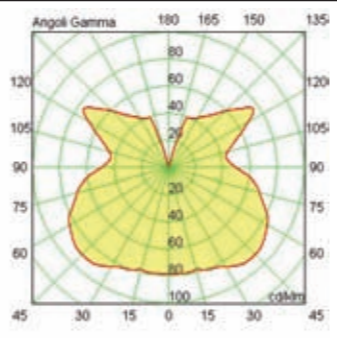
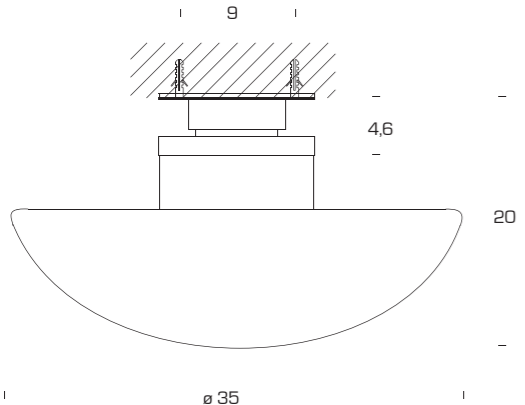

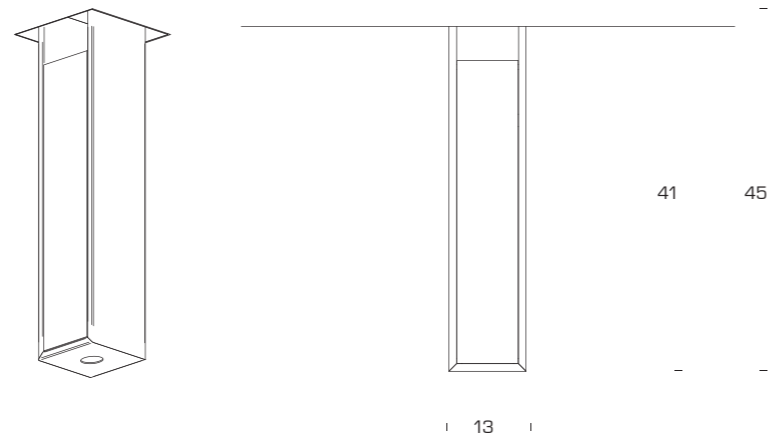

13

Lampada da semincasso.
Struttura in alluminio estruso anodizzato satinato [A] o anodizzato nero opaco [N]. Diffusori in vetro bianco satinato [BI] o arancione ambra satinato [AM]. Trasformatori inclusi.

Semi recessed lamp.
Structure in anodised satin-finish extruded aluminium [A] or anodized matt black [N]. Shades in white satin-finish glass [BI] or amber/orange satin-finish [AM]. Transformers included.

Lampe semi encastrée.
Structure en aluminium extrudé anodisé satiné [A] ou anodisé noir opaque [N]. Diffuseurs en verre blanc satiné [BI] ou orange/ambre satiné [AM]. Transformateurs inclus.

Halbeinbauleuchte.
Struktur aus Aluminium, stranggepresst, eloxiert, satiniert [A] oder eloxiert mattschwarz [N]. Schirme aus weißem satiniertem [BI] oder bernsteinfarbenen [AM] Glas. Trafo werden mitgeliefert.

Lámpara semi empotrable.
Estructura de aluminio extrudido anodizado satinado [A] o anodizado negro opaco [N]. Difusores de cristal blanco satinado [BI] o anaranjado ámbar satinado [AM]. Transformadores incluidos.



M5582.. A - N
struttura
V5528.. AM - BI
diffusore

M5582.. A - N
structure
V5528.. AM - BI
shades

M5582.. A - N
structure
V5528.. AM - BI
diffuseurs

M5582.. A - N
Struktur
V5528.. AM - BI
Schirme

M5582.. A - N
estructura
V5528.. AM - BI
difusores

M5582.. A - N + V5528.. AM - BI 13 x 41  1x18W (IN) 2G11 + 1x20W (HA)  GU4

   IP20



006/5, 006/20

Archivio Storico 1933

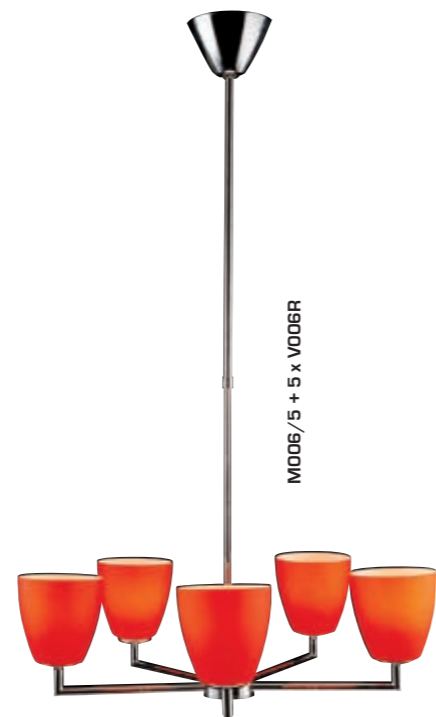

Lampada a sospensione. Montatura in ottone cromato. Diffusori in vetro soffiato e satinato nei colori bianco (BI), blu (BL), rosso (R), rosa (RS), verde (V). Diffusori disponibili in altri colori per quantitativi superiori a 100 pezzi.

Hanging lamp. Chrome-plated brass mounting. White (BI), blue (BL), red (R), pink (RS), green (V), satin blown glass diffusers. Diffusers available in other colours for quantities more than 100 pieces.

Suspension. Monture en laiton chromé. Diffuseurs en verre soufflé et satiné dans les couleurs blanc (BI), bleu (BL), rouge (R), rose (RS), vert (V). Diffuseurs in autres couleurs pour commandes au-dessus 100 de pièces.

Hängelampe. Gestell aus verchromtem Messing. Schirme aus satiniertem geblasenem Glas. Farben: weiß (BI), blau (BL), rot (R), rosa (RS), grün (V). Schirme in anderen Farben für Bestellungen höher als 100 Stücke.

Lámpara de techo. Montura de latón cromado. Difusor de cristal soplado y satinado de color blanco (BI), azul (BL), rojo (R), rosa (RS), verde (V). Difusores de otros colores para pedidos mayor de 100 piezas.

M006/5
montatura a 5 luci

M006/5
mounting with 5 lights

M006/5
monture avec 5 diffuseurs

M006/5
Gestell mit 5 Leuchten

M006/5
montura con 5 difusores

M006/20
montatura a 20 luci

M006/20
mounting with 20 lights

M006/20
monture avec 20 diffuseurs

M006/20
Gestell mit 20 Leuchten

M006/20
montura con 20 difusores

V006.. BI - BL - R - RS - V
diffusore

V006.. BI - BL - R - RS - V
difusor

V006.. BI - BL - R - RS - V
difusor

V006.. BI - BL - R - RS - V
Schirm

V006.. BI - BL - R - RS - V
difusor

M006/5 + V006.. BI - BL - R - RS - V Ø 55 x 75 / 145

5x60W (IN) o/ or 5x42W (HA) (ES) E14

M006/20 + V006.. BI - BL - R - RS - V 68 x 68 x 120

20x60W (IN) o/ or 20x42W (HA) (ES) E14

CE IP20 006/5 UL

M006/5 + 5 x V006..

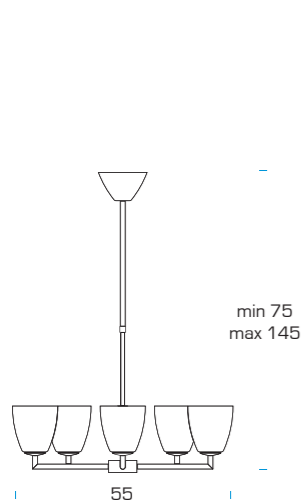

M006/20 + 20 x V006..

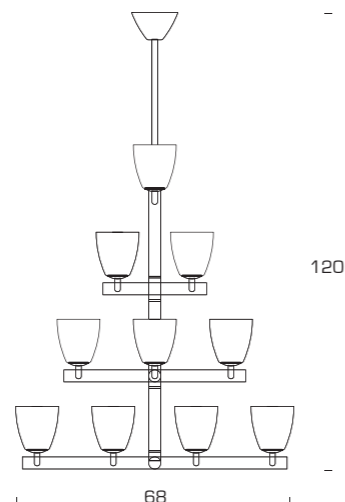

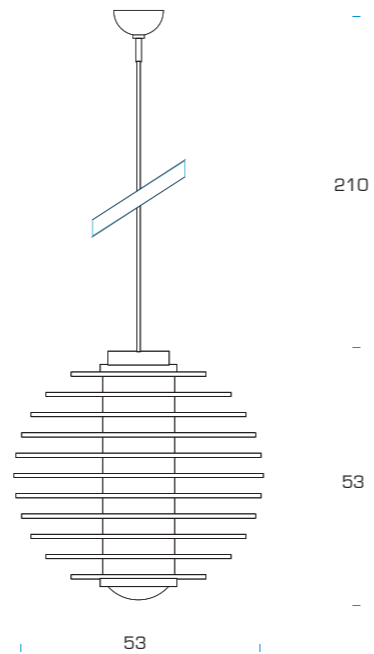

Lampada a sospensione. Dischi in vetro temperato trasparente. Diffusore cilindrico in vetro sabbato. Struttura in ottone cromato. Sorgente luminosa fluorescente dimmerabile che assicura un'ottima resa luminosa e un ridotto consumo energetico. A richiesta disponibile, come accessorio, un coperchio di chiusura inferiore con vetro satinato, che installato al posto del tappo in dotazione, consente di avere una doppia distribuzione luminosa: diffusa e concentrata sul piano. Il rosone, come tutti i particolari della struttura, è cromato.

Hanging lamp. Disks made of transparent tempered glass. Cylindrical diffuser in sandblasted glass. Structure in chrome-plated brass. Fluorescent dimmable lighting source that ensures high lighting performance and low energy consumption. Upon request a lower closing disk made of satin glass is available; it can be mounted instead of the plug, already included, permitting a double lighting emission: diffused and concentrated. The ceiling rose, as well as all the structure, is chrome-plated.

Suspension. Disques en verre trempé transparent. Diffuseur cylindrique en verre mat. Structure en laiton chromé. Source lumineuse fluorescente réglable, qui assure une illumination optimale et une consommation énergétique réduite. A la demande, est disponible comme accessoire un couvercle de fermeture inférieure en verre satiné, qui installé à la place du bouchon inclus, permet d'obtenir une double émission lumineuse, diffuse et concentrée. La rosace, tout comme la structure, est chromée.

Hängeleuchte. Vollkommen durchsichtige Kristallscheiben. Zylindrischer Streukörper aus satiniertem Glas. Struktur aus verchromten Messing. Fluoreszente dimmbare Leucht-Quelle, die einen optimalen Lichteffect mit reduziertem Stromverbrauch garantiert. Als Zubehör ist ein unterer Schließungsdeckel aus satiniertem Glas erhältlich, der, wenn anstelle des Standarddeckels eingesetzt, eine doppelte Lichtausstrahlung ermöglicht: verteilt und konzentriert. Die Rosette ist, wie sämtliche Strukturteile, verchromt.

Lámpara de techo. Discos de vidrio templado transparente. Difusor cilíndrico en vidrio arenado. Estructura de latón cromado. Surgente luminosa fluorescente dimmerable, que asegura óptima renta luminosa y reducido consumo energético. Sobre pedido es disponible, como accesorio, una tapa de cierre inferior con vidrio arenado, que instalado en lugar del tapón en dotación, permite tener una doble distribución luminosa: difundida y concentrada sobre el plano. El rosetón, como todos los particulares de la estructura, es cromado.

A0024
coperchio di chiusura inferiore

A0024
lower closing disk

A0024
couvercle de fermeture inférieure

A0024
unterer Schließungsdeckel

A0024
tapa de cierre inferior

0024VN ø 53 + 210  2x36W (FL) 2G11

   IP20



0024XXL

Gio Ponti 1931

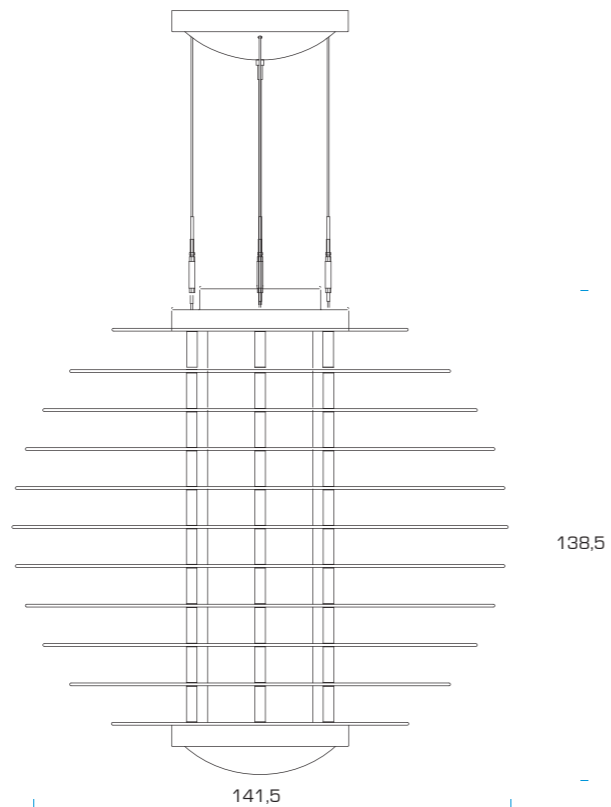

Lampada a sospensione. Montatura in ottone cromato. Dischi in vetro temperato trasparente. Il diffusore centrale cilindrico in vetro sabbiato del diametro di 30 cm, ospita 4 sorgenti luminose fluorescenti tipo T5 da 54W, con alimentazione elettronica digitale DALI. Dal copri rosone partono i 4 cavi di sospensione la cui lunghezza deve essere indicata all'ordine. Il livellamento della lampada, una volta appesa, avviene tramite gli appositi tenditori posti sui cavi di sospensione. A richiesta è disponibile una versione con dischi in metacrilato e/o con luce di emergenza: in questo caso due sorgenti luminose garantiscono un'autonomia di circa un'ora senza alimentazione. In considerazione del peso della lampada (circa Kg 300 nella versione con dischi in vetro e circa kg 200 nel caso di dischi in metacrilato) si impone una verifica preventiva sulla portata del soffitto.

Hanging lamp. Mounting in chrome plated metal. Disks in transparent tempered glass. The cylindrical diffuser in sandblasted glass houses 4 fluorescent lighting sources T5 of 54W, with electronic power supply DALI. The cover rose includes 4 hanging cables, whose length must be indicated when placing the order. The regulation of the lamp, once installed, take place by means of tensioners positioned on the hanging cables. On request it is available a version with disks made of methacrylate and with and or emergency light; in this case two lighting sources grant about one hour of light without power supply. Considering the weight of the lamp (about 300 Kg for the version with disks made of glass and about 200 Kg. for the version with disks made of methacrylate), the capacity of the ceiling must be checked in advance.

Lampe à suspension. Monture en laiton chromé. Disques en verre trempé transparent. Le diffuseur central cylindrique en verre sablé de 30 cm de diamètre abrite quatre sources lumineuses fluorescentes T5 de 54 W avec alimentation électronique numérique DALI. La longueur des câbles de suspension doit être précisée à la commande étant donné qu'aucune modification n'est possible lors de l'installation. Le réglage de la lampe, une fois suspendue, se fait à l'aide des tendeurs placés sur les câbles de suspension. Une version avec disques en méthacrylate et/ou lampe de secours est également disponible sur demande : dans ce cas, deux sources lumineuses garantissent une autonomie d'environ une heure sans alimentation. En raison du poids de la lampe (environ 300 kg pour la version avec disques en verre et environ 200 kg pour la version avec disques en méthacrylate), un contrôle préalable de la résistance

Pendelleuchte. Abhängung aus verchromtem Metall, Scheiben aus gehärtetem transparenten Glas. Der zylindrische mattierte Glasdiffusor verbirgt 4 Stück T5, 54W Leuchtstofflampen, die mit einem DALI EVG betrieben werden. Die Abdeckung beinhalten die 4 Pendelseile. Die Pendellänge muss bei der Bestellung festgelegt werden, da sie während der Installation nicht mehr verändert werden kann. Die Ausrichtung und Feinjustierung der montierten Leuchte erfolgt mittels Seilspannern am Seilende. Auf Anfrage, ist eine Version mit Scheiben aus Methacrylat und/oder einem Notlichteinsatz verfügbar. Der Notlichteinsatz mit Einzelbatterie garantiert eine Stunde lang, 50% der Leuchtenlichtleistung bei Stromausfall. In anbetracht des Gewichtes der Leuchte (300Kg für die Glasversion oder 200Kg für die Methacrylatversion) ist die Tragfähigkeit der Decke bauseits zu prüfen.

Lámpara de suspensión. Estructura de latón cromado. Discos de vidrio templado transparente. El difusor central cilíndrico en vidrio arenado de diámetro 30 cm, alberga 4 fluorescentes tipo T5 de 54W, con alimentación electrónica digital DALI. El cubre-rosetón incluye los 4 cables de suspensión. La longitud de los cables tiene que ser indicada en el pedido ya que no puede ser modificada durante la instalación. La regulación de la lámpara, una vez instalada, se hace a través de los tensores situados en los cables de suspensión. A petición, está disponible una versión con disco en metacrilato y/o con luz de emergencia: en este caso dos fuentes luminosas garantizan una autonomía de cerca de una hora sin alimentación. Considerando el peso de la lámpara (cerca de 350 Kg en la versión de disco en vidrio y cerca de 200 kg en el caso de disco en metacrilato) se debe verificar la resistencia del techo.

Piccolo Teatro, Milano



0024/3VN ø 141,5 x 138,5 4x54W (FL) G5

CE IP20

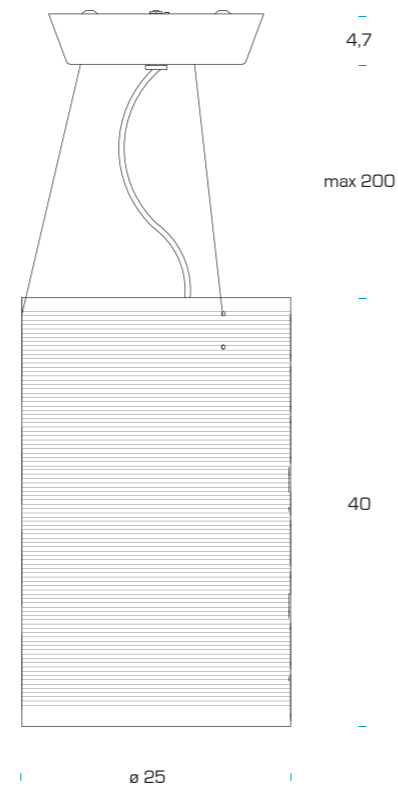

Lampada a sospensione.
Diffusore in vetro
trasparente avvolto da
cavo in Rilsan trasparente.
Rosone in metallo
verniciato bianco con cavi
di sospensione in acciaio e
cavo di alimentazione
trasparente.

Hanging lamp. Diffuser in
transparent glass wound
by a cable in transparent
Rilsan. Metal ceiling rose
painted in white colour.
Steel suspension cable.
Transparent feeding cord.

Suspension. Diffuseur en
verre transparent
enveloppé d'un câble
Rilsan transparent.
Fleuron en métal verni
blanc avec câble de
suspension en acier et
câble d'alimentation
transparent.

Hängelampe. Schirm aus
transparentem Glas,
durch ein transparentes
Kabel in Rilsan aufgewi-
ckelt. Rosette aus
lackiertem weißfarbigem
Metall mit Befestigungsseil
aus Edelstahl und
transparentem Netzkabel.

Lámpara de techo. Difusor
de cristal transparente
arrollado por un cable de
Rilsan transparente.
Rosetón de metal pintado
blanco. Cables de suspen-
sión en acero. Cable de
alimentación transparente.

3857/1	ø 25 x 40 + 200	☉	3x15W (FL) E27
3857/2	ø 25 x 40 + 200	☉	1x20W (FL) E27

CE IP20



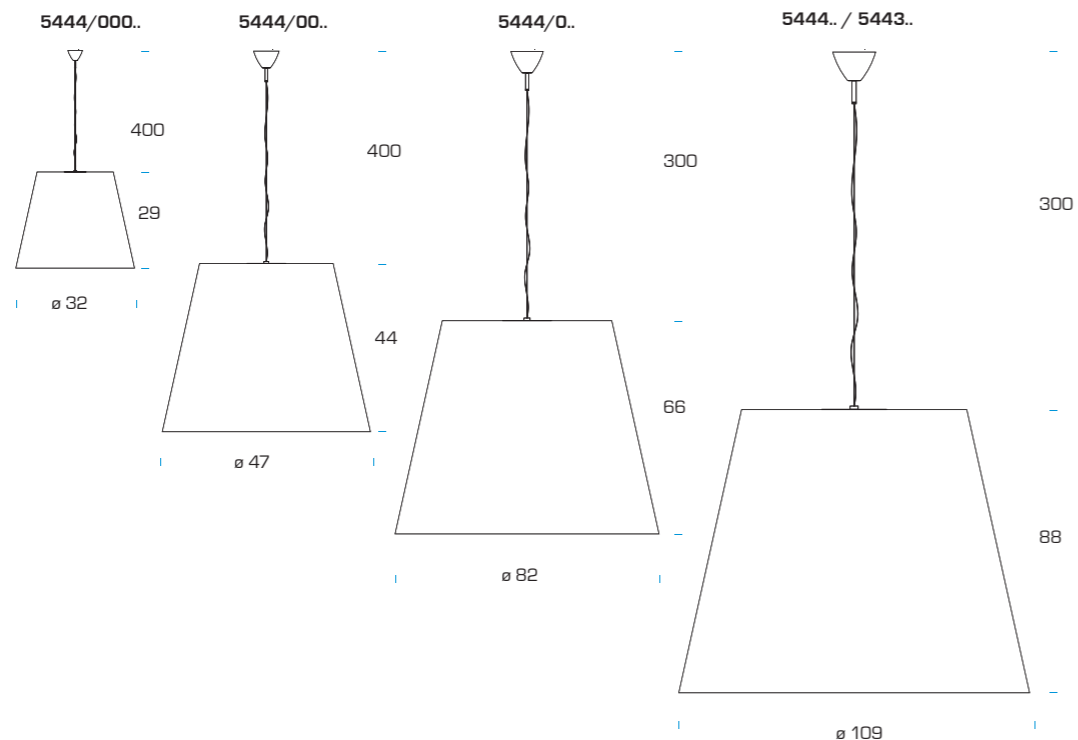

Lampada a sospensione. Montatura in metallo cromato. Diffusore in polietilene bianco all'interno e disponibile all'esterno nei colori bianco (BI), grigio (AG/BI) e nero (N/BI). Cavo di sospensione in acciaio. Cavo di alimentazione colorato. I modelli 5443., 5444. e 5444/O. possono montare come accessorio un disco di chiusura in metacrilato con tige e tappo di ancoraggio. Amax è disponibile su richiesta per ordini speciali anche con diffusore interno bianco e esterno argento metallizzato (MS/BI) oppure dorato (OO/BI).

Hanging lamp. Mounting in chrome-plated metal. Diffuser in polyethylene white colour inside and white (BI), grey (AG/BI) and black (N/BI) outside. Steel hanging cable. Coloured feeding cable. Models 5443., 5444. and 5444/O. can be equipped with a closing disc in methacrylate with suspension rod and fixing plug. Amax is available upon request for special orders with white diffuser inside and metallic silver (MS/BI) or gold (OO/BI) outside.

Suspension. Monture en métal chromé. Diffuseur en polyéthylène de couleur blanc à l'intérieur et disponible à l'extérieur dans les couleurs blanc (BI), gris (AG/BI) et noir (N/BI). Câble de suspension en acier. Câble d'alimentation à gaine colorée. Les modèles 5443., 5444. et 5444/O. peuvent monter un disque de fermeture en méthacrylate avec tige et bouchons d'ancrage. Amax est également disponible sur demande pour commandes spéciales avec diffuseur intérieur blanc et extérieur argent métallisé (MS/BI) ou bien doré (OO/BI).

Hängelampe. Gestell aus verchromtem Metall. Streukörper aus Polyäthylen innen weiß und außen in den Farben weiß (BI), grau (AG/BI) und schwarz (N/BI) erhältlich. Aufhängungskabel aus Stahl. Netzkabel farbig. Modelle 5443., 5444. und 5444/O. können mit einer Abschlusscheibe aus Methacryl mit Stiel und Schließkappe geliefert werden. Auf Nachfrage und für Sonderbestellungen kann Amax mit dem Streukörper innen weiß, außen silberfarben metallisiert (MS/BI) oder goldfarben (OO/BI) geliefert werden.

Lámpara de techo. Estructura en metal cromado. Difusor de polietileno internamente blanco y externamente disponible en color blanco (BI), gris (AG/BI) y negro (N/BI). Cable de suspension en acero. Cable de alimentación de color. Los modelos 5443., 5444 y 5444/O. se pueden equipar con un disco de cierre en metacrilato con barra de suspensión y tapa de anclaje. A petición y para pedidos especiales Amax está disponible con pantalla plateada (MS/BI) o dorada (OO/BI), siempre con la cara interna blanca.

5562
Ø 90 disco di chiusura opzionale per 5443. e 5444.

5562
Ø 90 optional closing disk for 5443. and 5444.

5562
Ø 90 disque de fermeture optionel pour 5443. et 5444.

5562
Ø 90 optionale Abschlusscheibe für 5443. und 5444.

5562
Ø 90 disco de cierre opzionale para 5443. y 5444.

5562/00
Ø 60 disco di chiusura opzionale per 5444/O.

5562/00
Ø 60 optional closing disk for 5444/O.

5562/00
Ø 60 disque de fermeture optionel pour 5444/O.

5562/00
Ø 60 optionale Abschlusscheibe für 5444/O.

5562/00
Ø 60 disco de cierre opzionale para 5444/O.

5444/000. AG/BI - BI - N/BI	ø 32 x 29 + 400		1x100W (HA) (ES) o/or 1x20W (FL) E27
5444/00. AG/BI - BI - N/BI	ø 47 x 44 + 400		1x150W (HA) (ES) o/or 1x20W (FL) E27
5444/0. AG/BI - BI - N/BI	ø 82 x 66 + 300		3x100W (HA) (ES) o/or 3x20W (FL) E27
5444. AG/BI - BI - N/BI	ø 109 x 88 + 300		3x150W (HA) (ES) o/or 3x20W (FL) E27
5443. AG/BI - BI - N/BI	ø 109 x 88 + 300		3x42W (FL) GX24q-4

IP20

5444/000. - 5444/00. - 5444/0. - 5444.





BI



AG/BI



N/BI



OO/BI



MS/BI

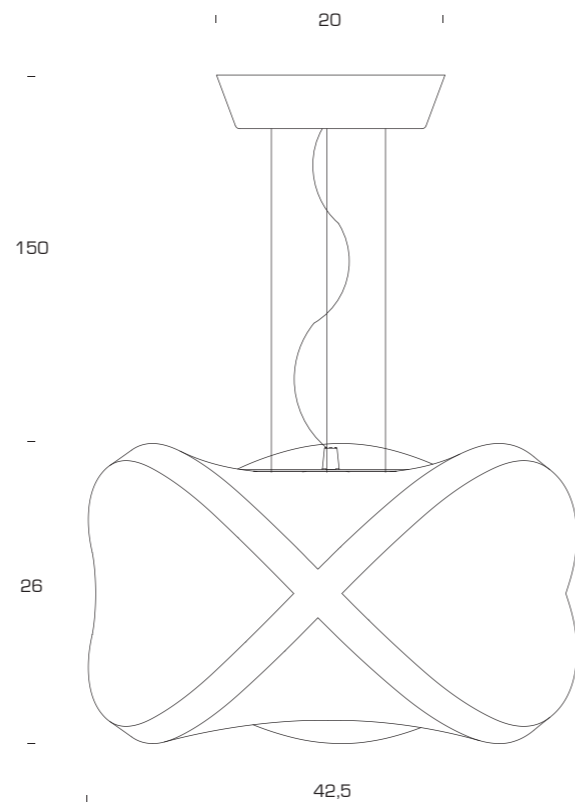

Lampada a sospensione.
Diffusore in vetro soffiato
bianco acidato. Rosone in
metallo verniciato bianco.
Cavi di sospensione in
acciaio. Cavo di
alimentazione trasparente.

Hanging lamp. White
acid-etched blown glass
diffuser. Metal ceiling rose
painted in white colour.
Steel suspension cables.
Transparent feeding cord.

Suspension. Diffuseur en
verre soufflé blanc traité
avec l'acide. Fleuron en
métal verni blanc avec
câble de suspension en
acier. Câble d'alimentation
transparent.

Pendelleuchte. Weißer
Leuchtschirm aus
geätztem Glas. Deckenro-
sette aus weiß lackiertem
Metall mit Stahlseilabhän-
gung. Transparente
Zuleitung.

Lámpara de techo.
Difusor de cristal soplado
blanco al ácido. Rosetón
de metal pintado blanco.
Cables de suspensión en
acero. Cable de alimenta-
ción transparente.

3649BI ø 42,5 x 26 + 150 1x150W (HA) (ES) E27

✓ ✓ ✓ CE IP20



A Tomic

Paolo Zani 2003



VQ Radisson, Dubai Marina, U.A.E.

Lampada a sospensione.
Montatura cromata.
Diffusore in vetro soffiato
bianco acidato. Cavo
saliscendi.

Hanging lamp. Chrome-
plated structure. Diffuser
in white blown acid-etched
glass. Rise and fall
counterweight cable.

Suspension. Structure
chromé. Diffuseur en
verre soufflé blanc traité
avec l'acide. Câble
réglable avec contrepoids.

Hängelampe.
Verchromtes Struktur.
Schirm aus weißem
mundgeblasem Ätztglas.
Mit höhenverstellbarem
Kabel.

Lámpara de techo.
Estructura cromada.
Difusor de cristal soplado
blanco al ácido. Cable de
sube y baja con
contrapeso.

3581	∅ 30 x 35+25 min (100 max)	1x150W (HA) E27
3581/1	∅ 45 x 52+25 min (100 max)	1x150W (HA) E27

IP20

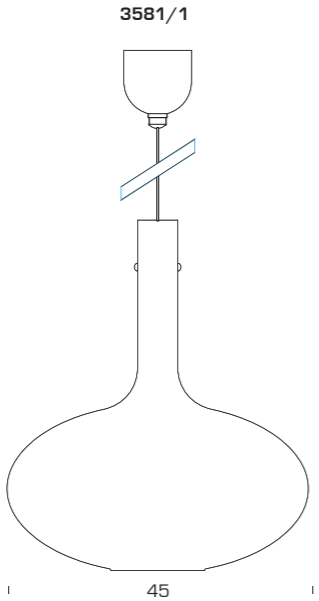
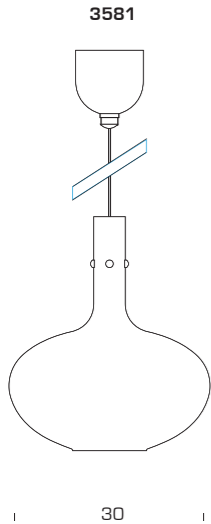

Salvarani, Giusano (MI)

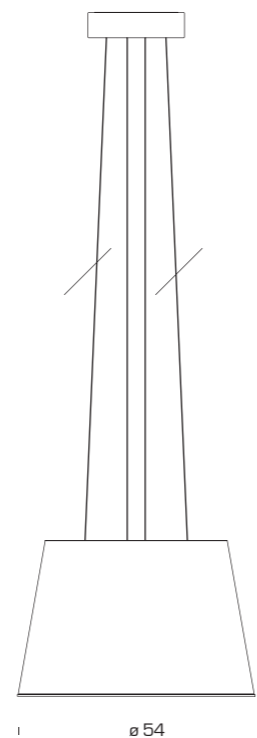

max 200

36

ø 54

Lampada a sospensione. Paralume esterno e rosone in alluminio verniciato color alluminio, bianco (BI), nero (N), oro (OO). Il paralume e il diffusore interno in polipropilene bianco nascondono la sorgente luminosa e producono una luce diffusa e leggera.

Hanging lamp. External shade and ceiling rose in aluminium painted aluminium colour, white (BI), black (N) or gold (OO). Internal shade in white polypropylene. The shades hide the lighting source and makes the light emission soft and diffused.

Suspension. Abat-jour extérieur et rosace en aluminium verni couleur aluminium, blanc (BI), noir (N) ou or (OO). L'abat-jour et le diffuseur interne en polypropylène blanc cachent la source lumineuse et produisent une lumière diffuse et légère.

Hängelampe. Äußerer Lampenschirm und Rosette aus Aluminium, lackiert aluminiumfarben, weiß (BI), schwarz (N) oder goldfarben (OO). Innerer Diffusor aus Polypropylen, weiß. Die Streukörper verstecken die Lichtquelle und produzieren somit ein diffuses und leichtes Licht.

Lámpara de techo. Pantalla exterior y rosetón en aluminio pintado de color aluminio, blanco (BI), negro (N) o oro (OO). Difusor interior en polipropileno blanco. Los conos ocultan la fuente luminosa para obtener una emisión de luz difusa.

5483 - 5483.. BI - N - OO ø 54 x 36+200 1x40W (FL) G10q

CE V U IP20

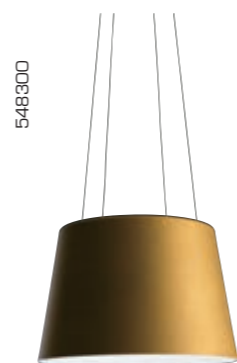
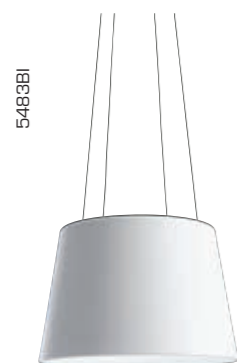

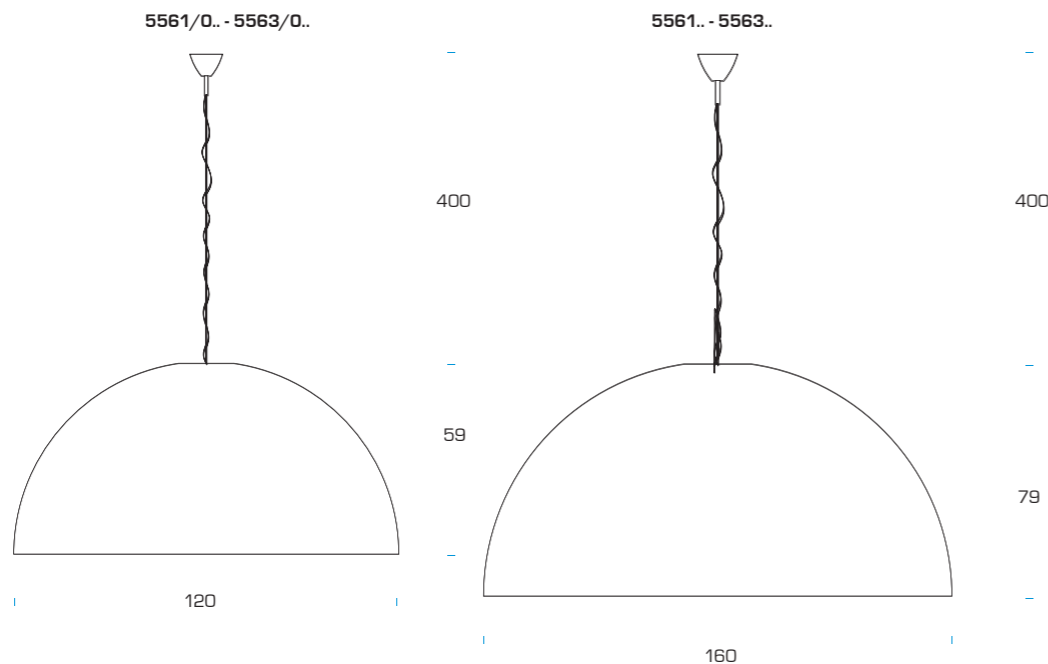

Lampada a sospensione. Montatura e rosone in metallo cromato. Diffusore in polietilene colore bianco all'interno (BI) e bianco all'esterno e verniciato all'esterno nei colori grigio (AG/BI) e nero (N/BI). Cavo di sospensione in acciaio. Cavo di alimentazione colorato. Disco di chiusura in metacrilato con tige e tappo di ancoraggio disponibile come accessorio. Avico è disponibile su richiesta per ordini speciali con diffusore interno bianco e esterno verniciato argento metallizzato (MS/BI) oppure dorato (OO/BI).

Hanging lamp. Mounting and ceiling rose in chrome-plated metal. Diffuser in polyethylene, white colour (BI) or white colour inside and painted grey (AG/BI) or black (N/BI) outside. Steel hanging cable. Coloured feeding cable. Closing disc in methacrylate with suspension rod and fixing plug available as an accessory. Avico is available upon request for special orders with diffuser white colour on the inside and painted metallic silver (MS/BI) or metallic gold (OO/BI) on the outside.

Suspension. Monture et rosace en métal chromé. Diffuseur en polyéthylène, couleur blanc (BI) et à l'intérieur blanc et à l'extérieur verni gris (AG/BI) et noir (N/BI). Câble de suspension en acier. Câble d'alimentation à gaine colorée. Disque de fermeture en méthacrylate avec tige et bouchons d'ancrage disponible comme accessoire. Avico est également disponible sur demande pour commandes spéciales avec diffuseur intérieur blanc et extérieur verni gris métallisé (MS/BI) ou bien métallisé doré (OO/BI).

Hängelampe. Gestell und Rosette aus verchromtem Metall. Streukörper aus Polyäthylen, weiß (BI) und innen weiß und außen in den Farben weiß (BI), grau (AG/BI) und schwarz (N/BI) lackiert. Aufhängungskabel aus Stahl. Netzkabel farbig. Als Zubehör Abschlußscheibe aus Methacryl mit Stiel und Schließkappe. Auf Nachfrage und für spezielle Bestellungen kann Avico mit dem Streukörper innen weiß, außen silberfarben metallisiert (MS/BI) oder goldfarben metallisiert (OO/BI) lackiert, geliefert werden.

Lámpara de techo. Estructura y rosetón en metal cromado. Difusor de polietileno, blanco (BI) y internamente pintado gris (AG/BI) y negro (N/BI). Cable de suspensión en acero. Cable de alimentación de color. Disco de cierre en metacrilato con varilla de suspensión y tapa de anclaje disponible como accesorio. A petición, y para pedidos especiales, Avico está disponible con pantalla pintada plateada (MS/BI) o dorada (OO/BI), siempre con la cara interna blanca.

5562
Ø 90 disco di chiusura opzionale per 5561.. e 5563..

5562
Ø 90 optional closing disk for 5561.. and 5563..

5562
Ø 90 disque de fermeture optionel pour 5561.. et 5563..

5562
Ø 90 optionale Abschlußscheibe für 5561.. und 5563..

5562
Ø 90 disco de cierre opzionale para 5561.. y 5563..

5562/00
Ø 60 disco di chiusura opzionale per 5561/O.. e 5563/O

5562/00
Ø 60 optional closing disk for 5561/O.. and 5563/O

5562/00
Ø 60 disque de fermeture optionel pour 5561/O.. et 5563/O..

5562/00
Ø 60 optionale Abschlußscheibe für 5561/O.. und 5563/O..

5562/00
Ø 60 disco de cierre opzionale para 5561/O.. y 5563/O..

5561/O.. AG/BI - BI - N/BI	Ø 120 x 59 + 400	☉	☉	3x100W (HA) (ES) o/ or 3x20W (FL) E27
5563/O.. AG/BI - BI - N/BI	Ø 120 x 59 + 400	☉	☉	3x32W (FL) GX24q-3
5561.. AG/BI - BI - N/BI	Ø 160 x 79 + 400	☉	☉	3x150W (HA) (ES) o/ or 3x20W (FL) E27
5563.. AG/BI - BI - N/BI	Ø 160 x 79 + 400	☉	☉	3x42W (FL) GX24q-4

CE IP20

UL 5561/O.. - 5561..

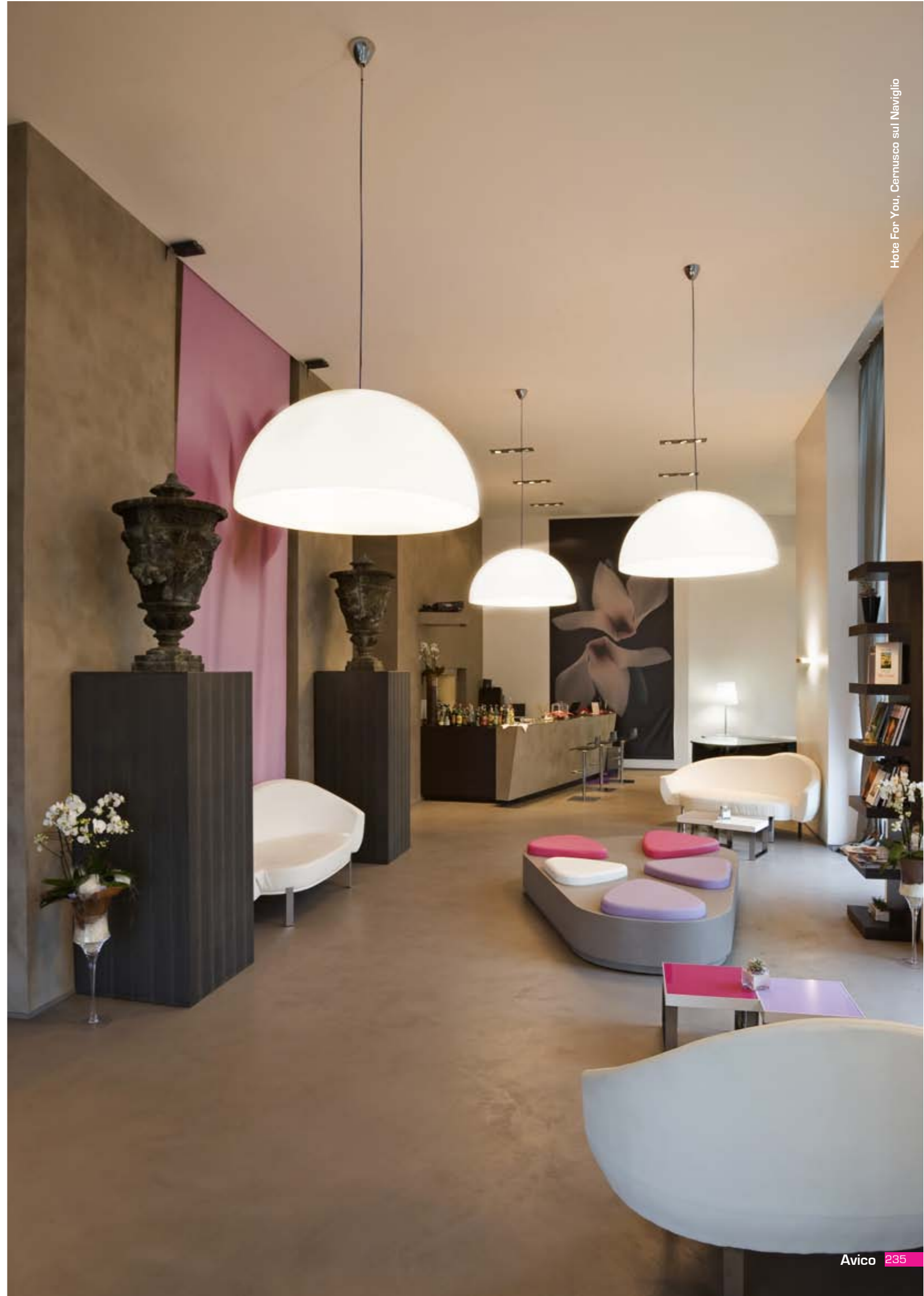



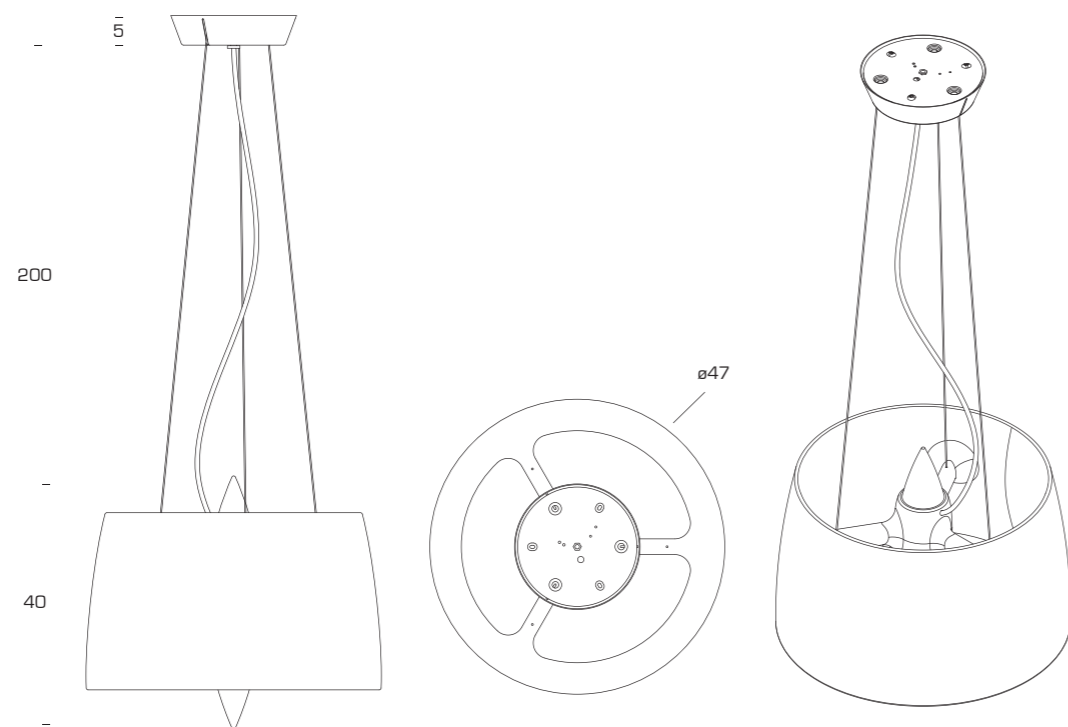

Lampada a sospensione. Supporto e paralume in nylon verniciato bianco lucido prodotto con tecnologia rotazionale. Disco diffusore inferiore in vetro verniciato bianco. Cavi di sospensione in acciaio. Cavo di alimentazione trasparente. Alloggia esclusivamente sorgenti luminose fluorescenti.

Hanging lamp. Support and shade in polished white painted nylon, manufactured through rotational moulding process. Lower disc diffuser in painted white glass. Steel hanging cables. Transparent feeding cable. It houses fluorescent lighting sources only.

Suspension. Support et abat-jour en nylon verni blanc brillant moulé avec technologie rotationnelle. Disque diffuseur inférieur en verre verni blanc. Câble de suspension en acier. Câble d'alimentation transparent. Elle accueille exclusivement des sources lumineuses fluorescentes.

Pendelleuchte mit Halterung und Schirm aus poliertem weiß lackiertem Nylon, im Rotationsverfahren hergestellt. Untere Scheibe aus weißem lackiertem Glas. Stahlseil Abhängung. Transparente Zuleitung. Ausschließlich mit Leuchtstofflampen bestückbar.

Lámpara de techo. Soporte y pantalla de nylon pintado blanco pulido producidos con tecnología rotacional. Disco difusor inferior de vidrio pintado blanco. Cables de suspensión en acero. Cable de alimentación transparente. Monta exclusivamente fuentes luminosas fluorescentes.



4022BI

ø 47 x 40 + 200



3x20W (FL) E27

CE Class II IP20

Balthazar

Daniela Puppa /
Francesca Martelli 2010

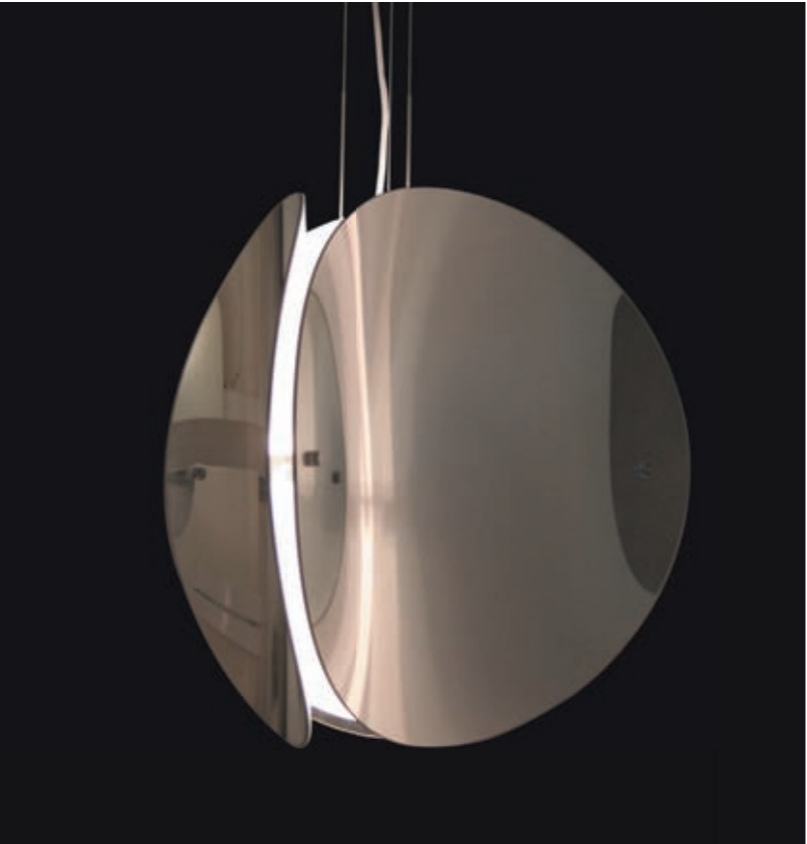

Lampada a sospensione. Diffusori in vetro curvato bianco (BI) oppure metallizzato cromato (CR). Rosone in metallo cromato lucido dal quale partono tre cavi di sospensione in acciaio e cavo di alimentazione trasparente.

Hanging lamp. Diffusers in curved white (BI) or metallized chrome-plated (CR) glass. From the ceiling rose in chrome-plated metal hang three hanging cables in stainless steel and a transparent feeding cable.

Suspension. Diffuseur en verre bombé blanc (BI) ou métallisé chromé (CR). Trois câbles de suspension en acier et un câble d'alimentation transparent sont suspendus à la rosace en métal chromé.

Hängeleuchte. Schirme aus gebogenem weißem (BI) oder metallisiertem verchromtem (CR) Glas. An der Rosette, aus verchromtem Metal, hängen drei Befestigungskabel aus Edelstahl und ein transparentes Netzkabel.

Lámpara de techo. Difusores de vidrio curvado blanco (BI) o metalizado cromado (CR). Cables de suspensión en acero y un cable de alimentación transparente penden del rosetón en metal cromado.

4108.. BI - SP ø 48,5 x 45 + 150 1x205W (HA) (ES) E27

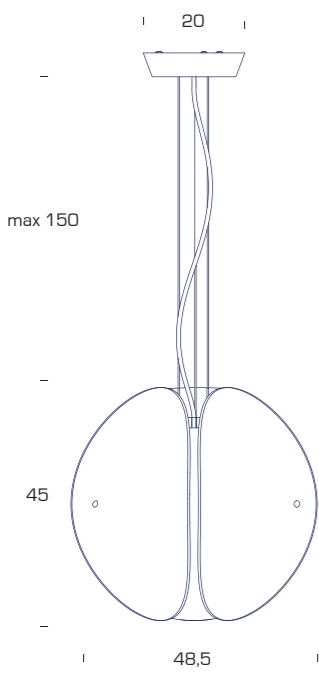

Bolla

Harry & Camila 2003



Lampada a sospensione. Diffusore in vetro soffiato trasparente con effetto iride. Rosone cromato. Cavo di alimentazione blu.

Hanging lamp. Diffuser in transparent blown glass with iris effect. Ceiling rose in chrome-plated brass. Blue feeding cable.

Suspension. Diffuseur en verre soufflé transparent à effet iridescent. Rosace en laiton chromé. Câble d'alimentation bleu.

Hängelampe. Schirm aus mundgeblasem transparentem Glas mit Regenbogeneffekt. Rosette aus verchromter Messing. Blaues Anschlusskabel.

Lámparas de techo. Difusor de cristal soplado transparente con efecto iris. Rosetón cromado. Cable de alimentación azul.

M3540CR
montatura
V3567/2TR
diffusore

M3540CR
mounting
V3567/2TR
shade

M3540CR
structure
V3567/2TR
diffuseur

M3540CR
Struktur
V3567/2TR
Schirm

M3540CR
estructura
V3567/2TR
difusor



M3540CR
montatura
V3567/1TR
diffusore



M3540CR
mounting
V3567/1TR
shade

M3540CR
structure
V3567/1TR
diffuseur

M3540CR
Struktur
V3567/1TR
Schirm

M3540CR
estructura
V3567/1TR
difusor

M3540CR + V3567/1TR 51 x 32 + 148  1x105W (HA)  E27

M3540CR + V3567/2TR 33 x 31 + 150  1x105W (HA)  E27

  IP20

M3540CR + V3567/2TR

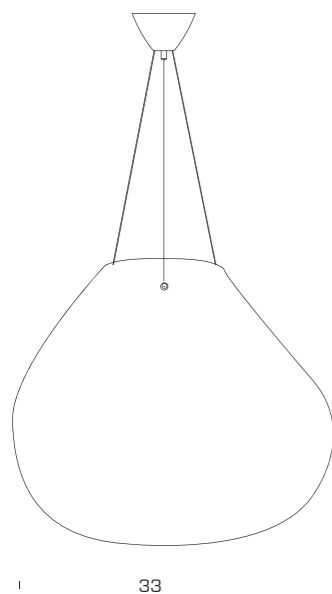

M3540CR + V3567/1TR

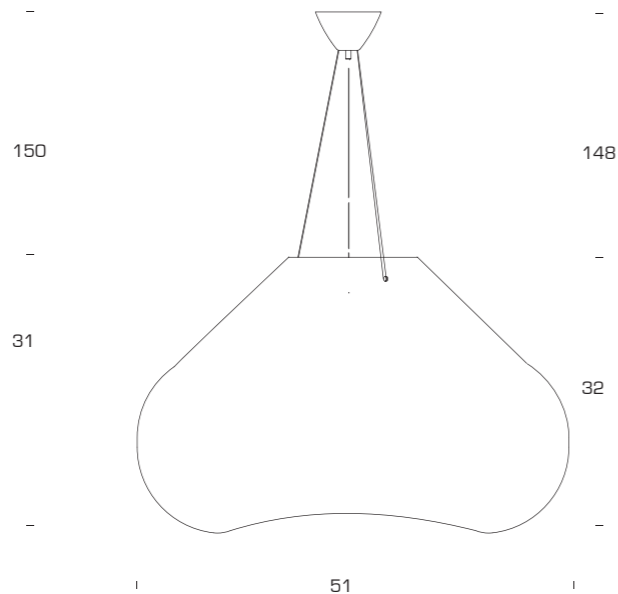

Salvarani, Giussano (MI)

Chandelier

David Chipperfield 2004



Lampada a sospensione a 1 o 2 anelli. Montatura in metallo verniciato grigio alluminio (G) o nero (N). Cavi di sospensione in acciaio inox. Diffusori in vetro borosilicato sabbato.

Hanging lamp with 1 or 2 rings. Structure in grey aluminium (G) or black (N) plated brass. Stainless steel suspension cables. Sandblasted borosilicate glass diffusers.

Suspension avec 1 ou 2 boucles. Monture en métal verni gris aluminium (G) ou noir (N). Câbles de suspension en acier inox. Diffuseurs en verre de borosilicate sablé.

Hängeleuchte mit 1 oder 2 Ringen. Struktur aus grauem (G) aluminium farbig oder schwarz (N) lackiertem Metall. Befestigungsseil aus Edelstahl. Schirme aus sandgestrahltem Borosilikatglas.

Lámpara de suspensión con 1 o 2 anillos. Estructura de metal pintado gris aluminio (G) o negro (N). Cables de suspensión de acero inoxidable. Difusores en vidrio borosilicato arenado.

5491/22.. - 5591/33..
doppia accensione

5491/22.. - 5591/33..
double switching

5491/22.. - 5591/33..
double allumage

5491/22.. - 5591/33..
Doppelschaltung

5491/22.. - 5591/33..
encendido double

5491/0.. G - N	ø 50 x 100	☞ ☞	8x40W (HA) o/ or 8x28W (HA) (ES) E14
5491.. G - N	ø 90 x 120	☞ ☞	14x40W (HA) o/ or 14x28W (HA) (ES) E14
5491/1.. G - N	ø 150 x 150	☞ ☞	19x40W (HA) o/ or 19x28W (HA) (ES) E14
5491/22.. G - N	ø 90 + ø 50 x 120	☞ ☞	8x40W (HA) o/ or 8x28W (HA) (ES) E14 + 14x40W (HA) o/ or 14x28W (HA) (ES) E14
5491/33.. G - N	ø 150 + ø 90 x 150	☞ ☞	14x40W (HA) o/ or 14x28W (HA) (ES) E14 + 19x40W (HA) o/ or 19x28W (HA) (ES) E14

CE F U IP20

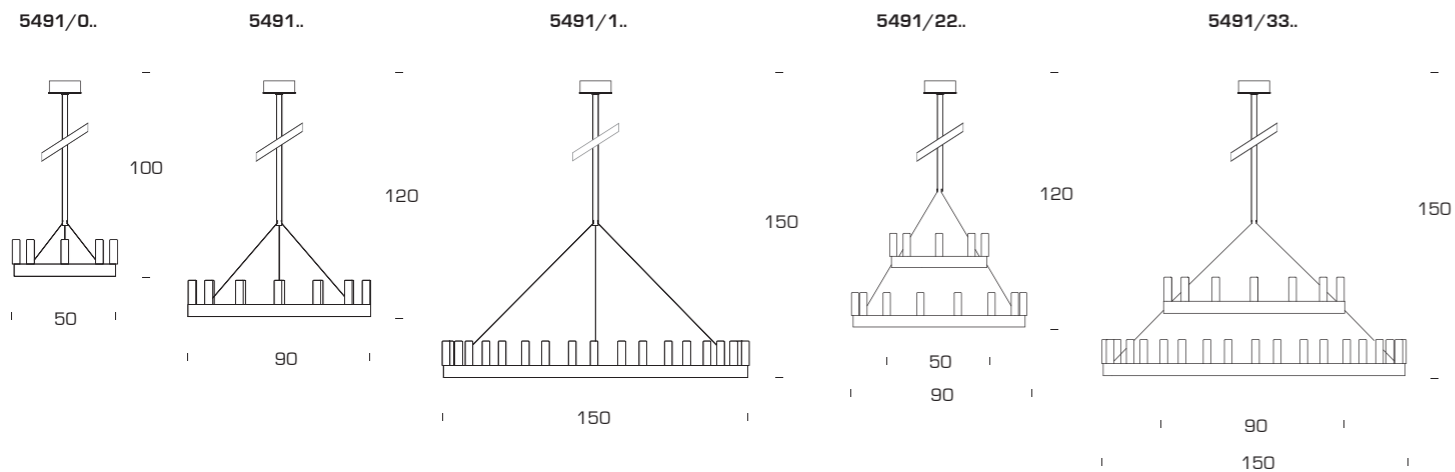

Lampada a sospensione.
Diffusore superiore in vetro centrifugato tipo midollino metallizzato esternamente. Diffusore inferiore in vetro soffiato bianco opalino acidato. Puntale cilindrico per il blocco del diffusore in metallo cromato. Rosone cromato con cavi di sospensione in acciaio regolabili. Cavo di alimentazione trasparente.

Suspension lamp. Upper diffuser in spinning glass "midollino"-type with external metal sheathing. Lower diffuser in opal white blown acid-etched glass. Cylindrical handgrips for the fixing of the diffusers in chrome-plated metal. Chrome-plated ceiling rose with adjustable hanging lamps in steel. Transparent feeding cable.

Suspension. Diffuseur supérieur en verre centrifugé type Midollino métallisé à l'extérieur. Diffuseur inférieur en verre soufflé blanc opalin acidé. Embouts cylindriques pour bloquer les diffuseurs en métal chromé. Rosace chromée avec câbles de suspension réglables en acier. Câble d'alimentation transparent.

Hängeleuchte. Oberer Streukörper aus zentrifugiertem Glas Typ "midollino", außen metallisiert. Unterer Streukörper aus weißem opal geätztem Glas. Zylindrische Metallspitze zur Befestigung von dem Schirm aus verchromtem Metall. Verchromte Rosette mit verstellbaren Befestigungskabeln aus Edelstahl. rasperentes Netzkabel.

Lámpara de techo. Difusor superior de vidrio centrifugado, tipo midollino metalizado externamente. Difusor inferior de vidrio soplado blanco opalino al ácido. Extremidades cilíndricas para el bloqueo del difusor en metal cromado. Rosetón de metal cromado con cables de suspensión ajustables en acero. Cable de alimentación transparente.

4035BI/CR	∅ 25,5 x 28 + 250	3x40W (HA) ES G9
4035/1BI/CR	∅ 53,5 x 59 + 250	3x70W (HA) ES G9

IP20

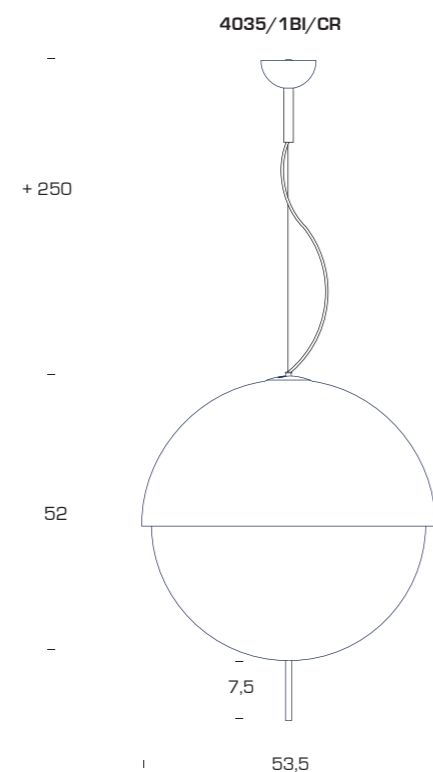
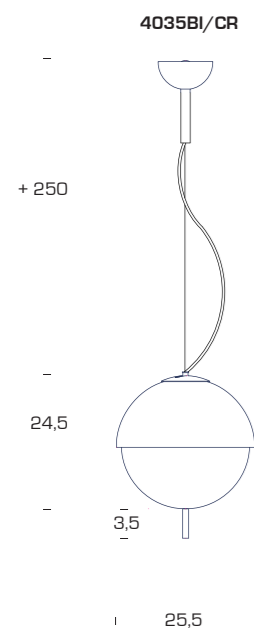

Cupola

Archivio Storico 1979



Lampada a sospensione.
Montatura in metallo
verniciato color alluminio
con interno bianco.
Cavo di alimentazione
trasparente.

Lampada a sospensione.
Montatura in metallo
verniciato color alluminio
con interno bianco.
Cavo di alimentazione
trasparente.

Suspension. Monture en
métal verni aluminium,
avec intérieur blanc. Câble
d'alimentation transparent.

Hängelampe. Metallge-
stell, lackiert, aluminium-
farben, innen weiß.
Transparentes Netzkabel.

Lámpara de techo.
Montura en metal pintado
en color aluminio con
interior blanco. Cable
de alimentación
transparente.

5117AN	ø 40 x 20 + 200	Ⓜ	1x105W (HA) Ⓜ E27
5117/1AN	ø 54 x 27 + 200	Ⓜ	1x140W (HA) Ⓜ E27

CE IP20

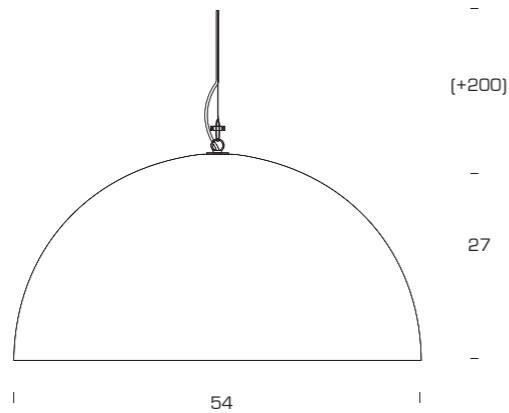
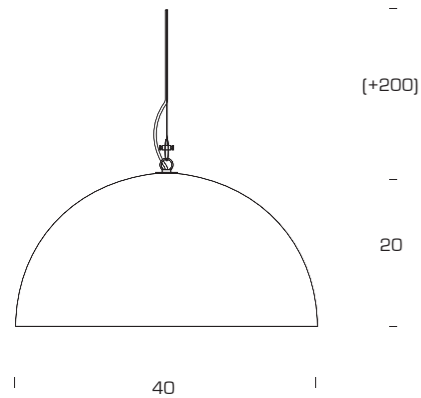

Salvarani, Giusano (MI)



25 Hours Hotel, Amburgo



Lampada a sospensione.
Diffusore in metacrilato
colato rosso (R) o satinato
(SA). Canalina in acciaio
lucidato. Portalampane
regolabili per una
diffusione diretta o
indiretta della luce.

Hanging lamp. Cast
methacrylate diffuser in
red (R) or satin (SA)
finishing. Polished steel
raceway. Adjustable
lampholders for direct or
indirect light emission.

Suspension. Diffuseur en
méthacrylate coulé de
couleur rouge (R) ou satiné
(SA). Conduite pour fils en
acier poli. Douilles réglables
pour une diffusion directe
ou indirecte de la lumière.

Hängelampe. Metallgestell,
verchromt. Gegossener
Metakryl-Schirm, rot (R)
oder satiniert (SA).
Regulierbare Lampenfas-
sungen zur direkten und
indirekte Lichtverteilung.

Hängelampe. Metallgestell,
verchromt. Gegossener
Metakryl-Schirm, rot (R)
oder satiniert (SA).
Regulierbare
Lampenfassungen zur
direkten und indirekte
Lichtverteilung.

5306.. R - SA	20 x 10 + 200	 2x50W (HA) E27
5306/1.. R - SA	40 x 10 + 200	 4x50W (HA) E27

   IP20

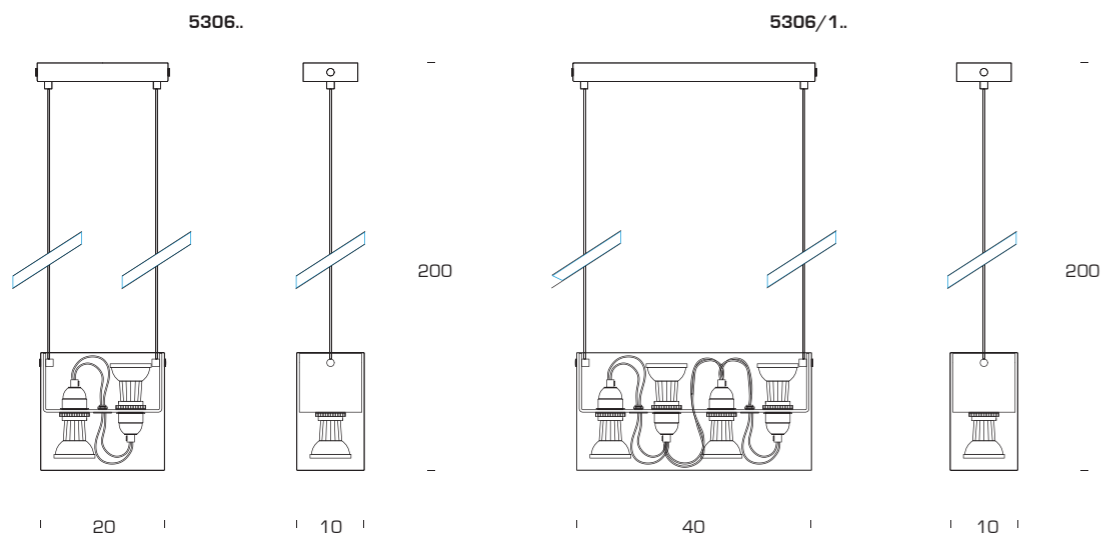



VQ Radisson, Dubai Marina, U.A.E.

Lampada a sospensione. Montatura in ottone cromato. Diffusore in metacrilato bianco (BI) o blu (BL) con inserti di tessuto. Cavo di alimentazione trasparente.

Hanging lamp. Frame in chrome-plated brass. Diffuser in methacrylate white (BI) or blue (BL) with fabric inserts. Transparent electric cord.

Suspension. Monture en laiton chromé. Diffuseur en méthacrylate blanc (BI) ou bleu (BL) avec insertions de tissu. Câble d'alimentation transparent.

Hängelampe. Messing-Gestell, verchromt. Metakryl-Schirm weiß (BI) oder blau (BL), mit Stoff-Einsätzen. Transparentes Netzkabel.

Lámpara de techo. Estructura de latón cromado. Difusor de metacrilato blanco (BI) o azul (BL) con aplicaciones de tejido. Cable de alimentación transparente.

M5307
montatura
P5265.. BI - BL
diffusore

M5307
mounting
P5265.. BI - BL
diffuser

M5307
monture
P5265.. BI - BL
diffuseur

M5307
Gestell
P5265.. BI - BL
Schirm

M5307
estructura
P5265.. BI - BL
difusor

M5367
montatura
P5367.. BI - BL
diffusore

M5367
mounting
P5367.. BI - BL
diffuser

M5367
monture
P5367.. BI - BL
diffuseur

M5367
Gestell
P5367.. BI - BL
Schirm

M5367
estructura
P5367.. BI - BL
difusor

M5307 + P5265.. BI - BL 34 x 18 x 30 + 200 1x105W (HA) E27

M5367 + P5367.. BI - BL 100 x 19 x 30 + 150 5x105W (HA) E27

IP20

M5307 + P5265..

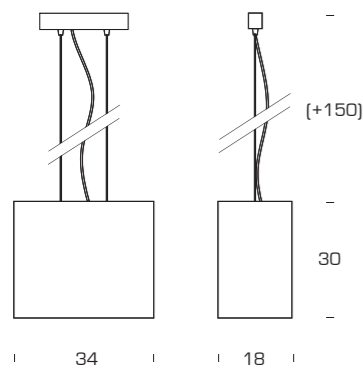

M5367 + P5367..

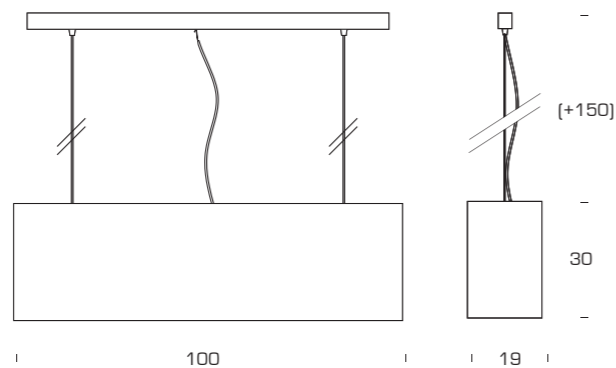

VQ Radisson, Dubai Marina, U.A.E.

Flûte 1 - Magnum

Franco Raggi 1999

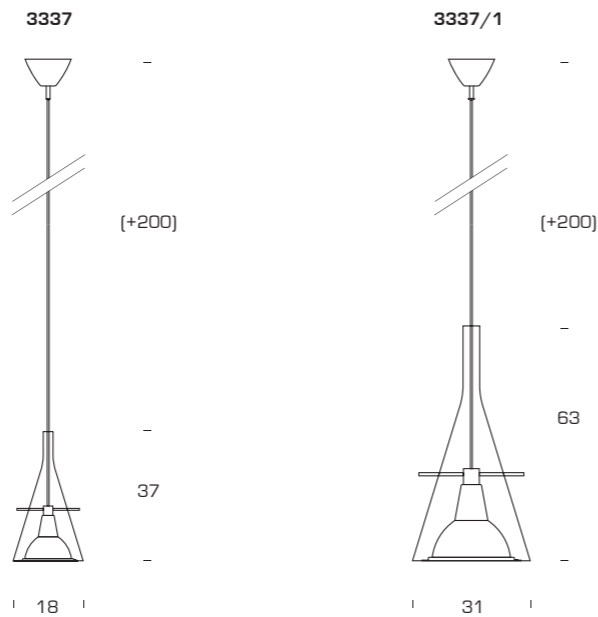

Lampada a sospensione. Diffusore in vetro borosilicato trasparente. Riflettore in alluminio cromato lucido. Cavo di alimentazione trasparente. Il cono di vetro accoglie al suo interno il riflettore sorretto da tre bracci cromati. La luce si riflette all'interno del cono e si diffonde in modo uniforme verso il basso.

Hanging lamp. Borosilicate transparent glass diffuser. Reflector in chrome-plated polished aluminium. Transparent feeding cable. The cone houses a reflector hold by three chrome-plated arms. The light reflects into the cone, thus giving a uniform light emission downwards.

Suspension. Diffuseur en verre de borosilicate transparent. Réflecteur en aluminium chromé poli. Câble d'alimentation transparent. Le cône de verre recueille en son intérieur le réflecteur soutenu par trois bras chromés. La lumière se reflète à l'intérieur du cône et se diffuse de manière uniforme vers le bas.

Hängelampe. Diffusor aus Borosilikat-Glas. Reflektor aus verchromtem glänzendem Aluminium. Transparentes N etzkabel. Drei schmale horizontale Stäbe halten einen Kegel fest, der in seinem innerem die Fassung hat. Der Kegel reflektiert das Licht und dank des Glasstreckkörpers, der den Lichtstrahl nach unten orientiert, erhält man eine gleichmäßige Lichtverteilung innerhalb des Raumes.

Lámpara de techo. Difusor de cristal al borosilicato. Reflector de aluminio cromado pulido. Cable de alimentación transparente. La luz es reflejada dentro el cono y agradece al difusor que dirige la luz hacia abajo una emisión uniforme y difundida ligera de luz es obtenida.

3337	∅ 18 x 37 + 200		1x60W (HA) o/or 1x42W (HA)
3337/1	∅ 31 x 63 + 200		1x230W (HA)

IP20 3337

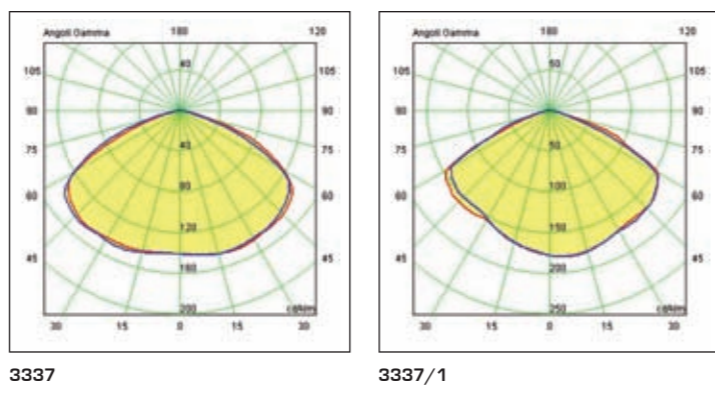

3337

3337/1



Flûte 2, 3

Franco Raggi 1999



Lampada a sospensione provvista di due oppure tre luci montate su canalina con interasse cm 50. Diffusori in vetro borosilicato trasparente. Riflettori in alluminio cromato lucido. Cavo di alimentazione trasparente.

Hanging lamp provided with two or three diffusers mounted on a raceway having a 50 cm distance between centres. Borosilicate glass diffusers. Polished chrome-plated aluminium reflectors. Transparent feeding cable.

Suspension pourvue de deux ou trois lampes montées sur une conduite de câbles avec un entraxe de 50 cm. Diffuseur en verre de borosilicate transparent. Réflecteur en aluminium chromé brillant. Câble d'alimentation transparent.

Hängelampe verfügt über zwei oder drei auf einer Rinne befestigten Leuchten, mit Achsabstand von 50 cm. Schirme aus Borosilikat-Glas. Reflektoren aus verchromtem, glänzendem Aluminium. Transparentes Netzkabel.

Lámpara de techo, tienes dos ou tres luces montadas en riel con intereje 50 cm. Difusores de cristal al borosilicato. Reflectores de aluminio cromado pulido. Cable de alimentación transparente.

3337/2	ø 80 x 18 x 180		2x60W (HA) o/or 2x42W (HA)
3337/3	ø 130 x 18 x 180		3x60W (HA) o/or 3x42W (HA)

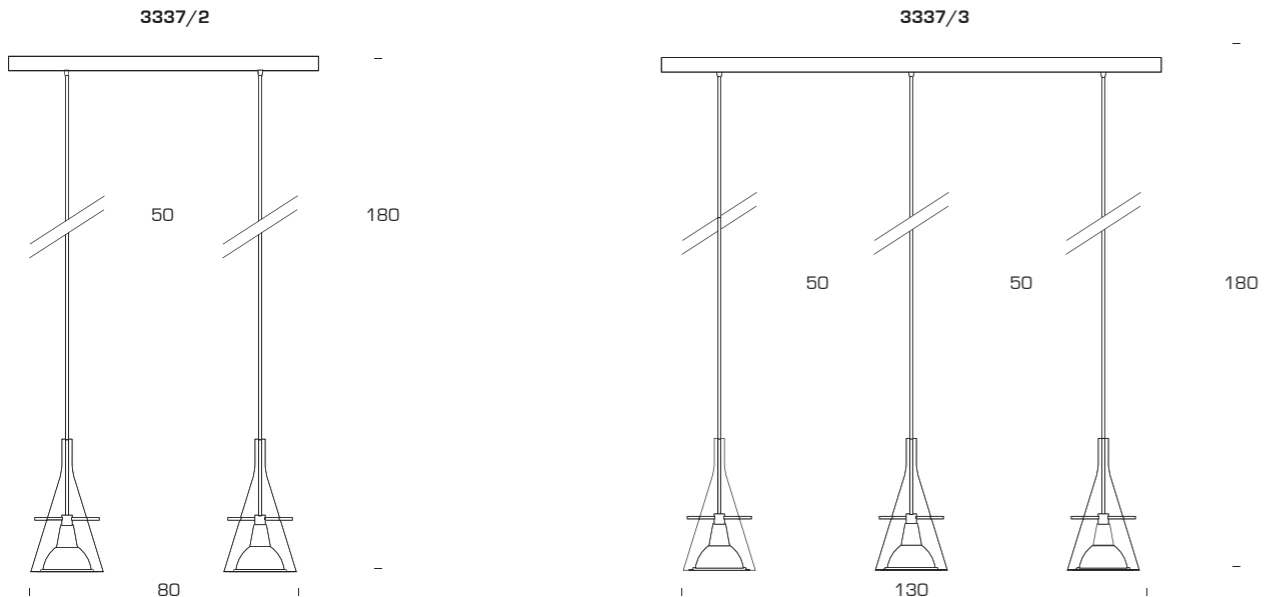

Varenna, Salone del Mobile, Milano

Globo di Luce

Roberto Menghi 1968



Lampada a sospensione. Globo in vetro soffiato argento metallizzato. Riflettore in alluminio anodizzato. Cavo di alimentazione trasparente.

Hanging lamp. Metallic silver blown glass globe. Anodised aluminium reflector. Transparent feeding cable.

Suspension. Globe en verre soufflé chromé métallisé. Réflecteur en aluminium anodisé. Câble d'alimentation transparent.

Hängelampe. Kugel aus metallisiertem silberem mundgeblasenem Glas. Reflektor aus eloxiertem Aluminium.

Lámpara de suspensión. Globo en cristal soplado metalizado plateado. Reflector de aluminio anodizado. Cable de alimentación transparente.

3644/OCR	∅ 20 x 19 + 250	🔊	1x40W (HA) E14 PAR16
3644CR	∅ 30 x 29 + 250	🔊	1x60W (HA) (ES) G9
3644/1CR	∅ 45 x 43 + 250	🔊	1x150W (HA) (ES) E27

IP20 3644CR - 3644/1CR 3644/1CR

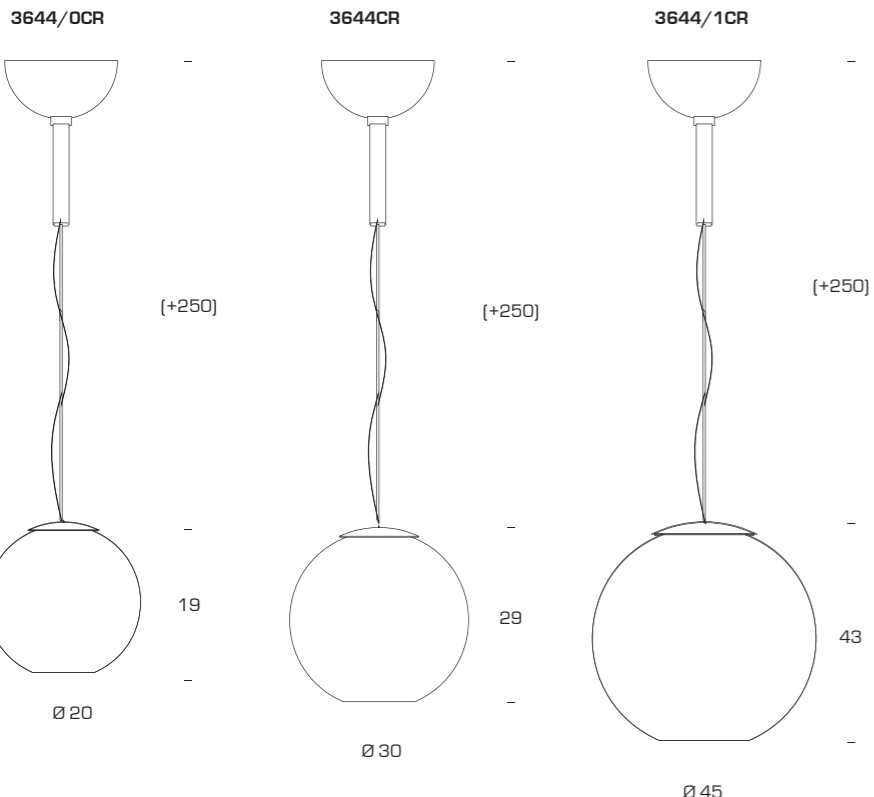

Bonaldo, Salone del Mobile, Milano





Lampada a sospensione.
Montatura in metallo
verniciato color alluminio
(AN), cromato (CR) o nero
(N) con interno bianco.
Cavo di sospensione in
acciaio inox. Cavo di
alimentazione trasparente.

Suspension lamp.
Mounting in metal painted
aluminium colour (AN),
chrome-plated (CR) or
black (N) with white
interior. Suspension cable
in stainless steel.
Transparent power cable.

Suspension. Monture en
métal verni aluminium (AN),
chromé (CR) ou noir (N),
intérieur blanc. Câble de
suspension en acier inox.
Câble d'alimentation
transparent.

Hängelampe. Metallgestell,
lackiert, aluminiumfarben
(AN), verchromt (CR) oder
schwarz (N), innen weiß.
Edelstahlkabel zur
Aufhängung. Transparentes
Netzkabel.

Lámpara de techo.
Montura en metal pintado
de color aluminio (AN),
cromado (CR) o negro (N)
con interior blanco. Cable
de suspensión en acero
inoxidable. Cable de
alimentación transparente.

5059.. AN - CR - N ø 40 x 30 + 250 1x140W (HA) or 1x20W (FL) E27

IP20

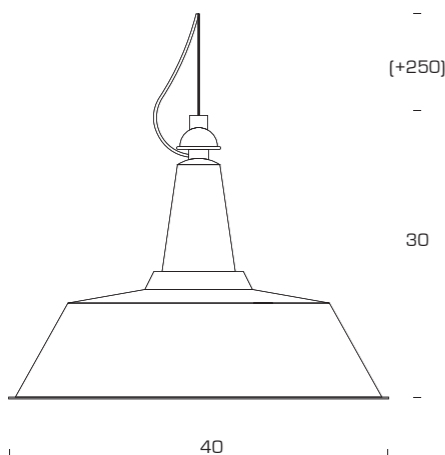

Lampara

Archivio Storico 1965



Playlife, Milano

Lampada a sospensione. Montatura in alluminio naturale (AN) oppure cromato (CR). Riflettore verniciato bianco all'interno. Cavo di sospensione in acciaio inox. Cavo di alimentazione trasparente.

Hanging lamp. Mounting in natural aluminium (AN) or chrome-plated (CR). White painted reflector on the inside. Stainless steel hanging cables. Transparent feeding cable.

Suspension. Monture en aluminium naturel (AN) ou chromé (CR). Reflecteur verni blanc à l'intérieur. Câble de suspension en acier inox. Câble d'alimentation transparent.

Hängelampe. Gestell aus natur Aluminium (AN) oder verchromt (CR). Innerer Reflektor weiß lackiert. Edelstahlkabel zur Aufhängung. Transparentes Netzkabel.

Lámpara de techo. Estructura en aluminio natural, (AN) o cromada (CR). Reflector blanco pintado en el interior. Cable de suspensión en acero inoxidable. Cable de alimentación transparente.

5000AN	ø 27 x 30 + 200	Ⓢ Ⓢ	1x60W (IN) o/or 1x42W (HA) Ⓢ E27
5000/1.. AN - CR	ø 35 x 40 + 200	Ⓢ	1x105W (HA) Ⓢ E27
5000/2.. AN - CR	ø 40 x 45 + 200	Ⓢ	1x140W (HA) Ⓢ E27

CE IP20 15 D UL 5000/2AN

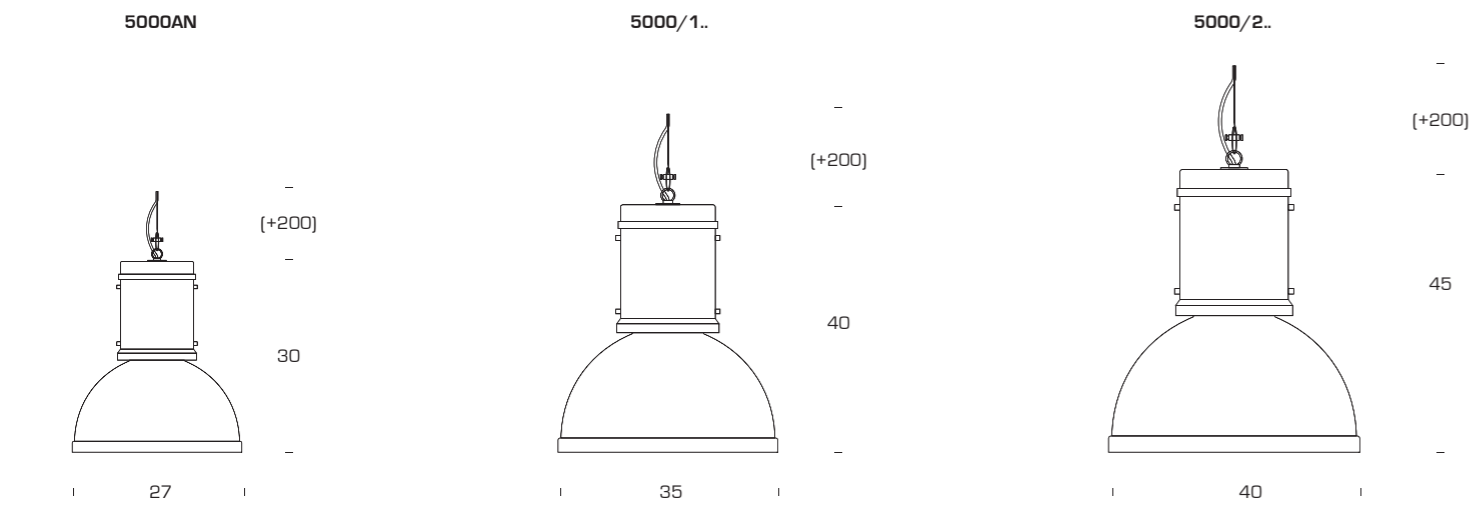

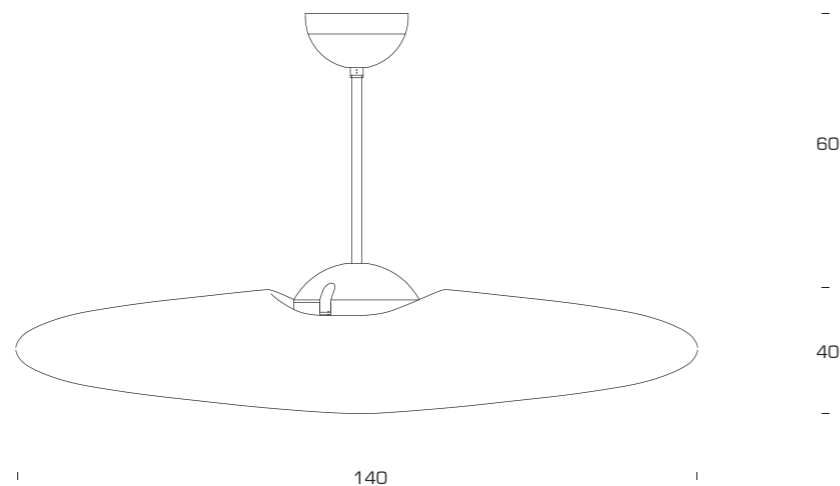

Lampada-ventilatorea sospensione. Diffusore in polietilene bianco ottenuto mediante stampaggio rotazionale. Montatura in ottone verniciato bianco. Rosone superiore in metallo verniciato, rosone inferiore (a copertura del dispositivo per la ventilazione) in polietilene. La lampada, dotata di motore a rotore con potenza di 85W, ha funzione anche di ventilatore.

Hanging lamp with fan. Diffuser in white polyethylene, produced by means of rotational moulding. Brass mounting painted white. Upper rose in painted metal, lower rose (covering the fan mechanism) in polyethylene. The luminaire is provided with a 85W rotor motor that allows it to function also as a fan, either with a remote control system.

Suspensionv entileteur. Diffuseur en polyéthylène blanc obtenu par moulage rotationnel. Monture en laiton verni blanc. Fleuron supérieur en métal peint, fleuron inférieur (couvrant le dispositif de la ventilation) en polyéthylène. La lampe, dotée de moteur à rotor d'une puissance de 85W, a également une fonction de ventilation avec système de commande à ondes radio.

Hängelampe mit Ventilator. Schirm aus Polyäthylen weiß hergestellt durch Rotationspressung. Gestell aus Messing, weiß lackiert. Obere Rosette aus lackiertem Metall, untere Rosette (Abdeckung des Ventilatorelements) aus Polyäthylen. Die Leuchte verfügt über einen 85W-Drehmotor und dient auch als Ventilator mit Funkwellen-Fernbedienung.

Lámpara de techo con ventilador. Difusor en polietileno blanco obtenido a través de moldeado rotacional. Montura de latón barnizado blanco. Rosetón superior en metal barnizado, rosetón inferior (cobertura del aparato para la ventilación) en polietileno. La lámpara, dotada de motor a rotor con potencia de 85W, también tiene función de ventilador con sistema de mando a radioondas.

Deposito di brevetto internazionale.

International patent pending.

Dépôt de brevet international.

Internationales angemeldet.

Depósito de patente internacional.

Modello comunitario depositato.

Design patent pending.

Modèle communautaire déposé.

Eingetragenes Warenzeichen.

Modelo comunitario depositado.

M5467/2BI/BI + V5467BI 140 x 40 + 35 2x30W (FL) E27

CE Class II IP20



Lunapiena

RobertoR ighetti 2003



Lampada a sospensione.
Montatura e rosone
in metallo verniciato
bianco. Diffusore in
polimetilmetacrilato. Cavo
di alimentazione
trasparente.

Hanging lamp. White
painted metal frame and
ceiling rose. Diffuser in
polymethylmethacrylate.
Transparent feeding
cable.

Suspension. Structure et
rosaceen métal verni
blanc. Diffuseur en
polyméthacrylate.
Câble d'alimentation
transparent.

Hängelampe. Struktur und
Rosette aus weiß
lackiertem Metall. Schirm
aus Polymethacrylat.
Transparentes Netzkabel.

Lámparas de techo.
Estructura y rosetón de
metal pintado blanco.
Difusor de
polimetilmetacrilato. Cable
de alimentación
transparente.

5448 Ø 41 x 4 + 150 - 1x55W (FL) GX13

CE IP20

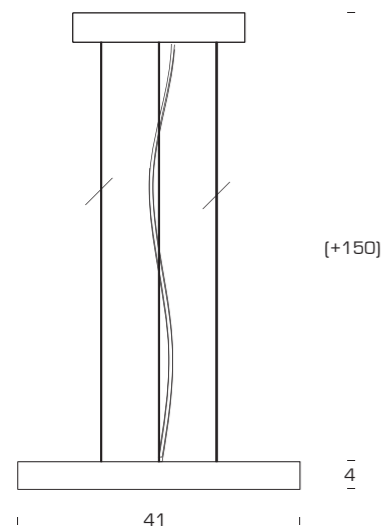

Morocco

Vico Magistretti 1998



Lampada a sospensione. Montatura cromata con griglia a binario per l'alloggiamento di massimo 36 bicchieri (non forniti) che, oltre ad avere funzione estetica, permettono anche la rifrazione della luce.

Hanging lamp. Chrome-plated frame with a grid track containing up to 36 glasses (not provided) that, apart from having an aesthetical function, also allow the refraction of the light.

Suspension.M onture chromé avec grille à rail permettant le positionnement de maximum 36 verres (exclus). Indépendamment de leur rôle esthétique, ils favorisent la réfraction de la lumière.

Hängelampe. Gestell aus verchromtem Metall mit Gleisnetz für maximal 36 Gläser (nicht geliefert), die nicht nur der Ästhetik dienen, sondern auch das Licht brechen.

Lámpara de techo. Estructura cromada con parrilla de riel para asiento de máx. 36 vasos (excluidos) que, además de contar con función estética, también permiten la refracción de la luz.

3246	56 x 56 + 140		8x50W (HA) o/or 8x40W (HA) GZ10
3246/1	56 x 56 + 170		8x50W (HA) o/or 8x40W (HA) GZ10

IP20

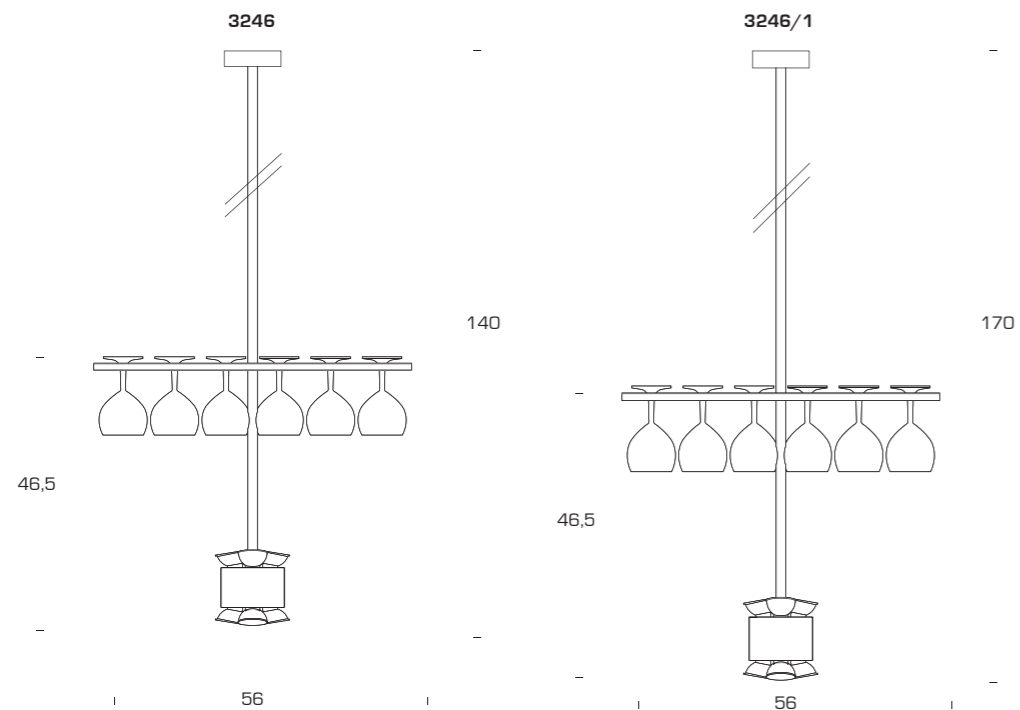

Hotel Style, Vienna (A)

Noaxis

Alessandro Pedretti /
Studio Rota & Partners 2007



Lampada a sospensione.
Struttura in vetroresina
verniciata bianca (BI) o
nera (N). Diffusore in
vetro.

Hanging lamp. Structure
in painted white (BI) or
black (N) fibreglass. Glass
diffuser.

Suspension. Structure en
fibre de verre vernie blanc
(BI) ou noir (N). Diffuseur
en verre.

Hängelampe. Gestell aus
lackiertem weißem (BI)
oder schwarzem (N)
Glasfaserkunststoff. Schirm
aus Glas.

Lámpara de techo.
Estructura en fibra de
vidrio pintada blanca (BI)
ou negra (N). Difusor de
vidrio.

Modello comunitario
depositato

Design patent pending

Modèle communautaire
déposé

Eingetragenes
Warenzeichen

Modelo comunitario
depositado

3902.. BI-N Ø 63 x 76 1x140W (HA) E27

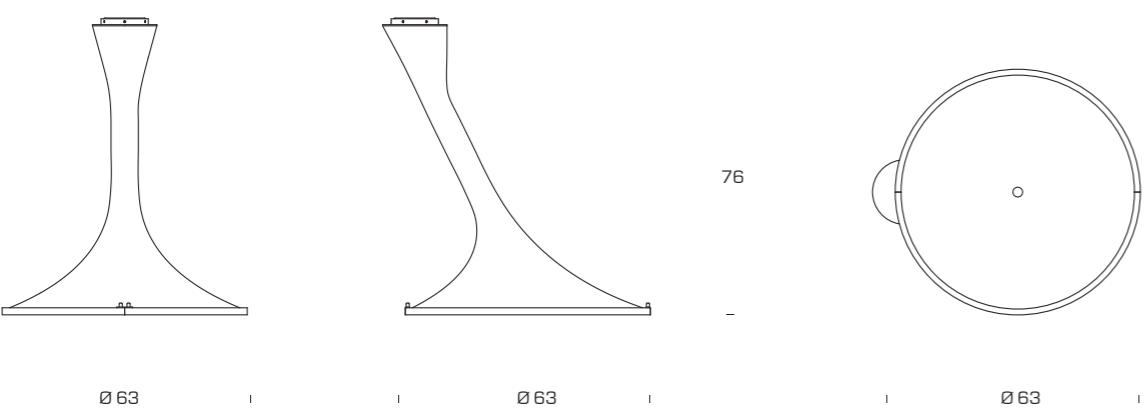

Hotel Boscolo Exedra, Milano







Lampada a sospensione. Montatura in metallo cromato (CR), verniciato grigio alluminio (G) oppure nichelato satinato (NS). La lampada è fornita con riflettore in alluminio anodizzato per luce indiretta e diffusori in vetro stampato, temperato e sabbato. Scatola distanziale inclusa. I modelli 3085.., 3358.. e 3358/1 sono provvisti di tige telescopica.



Hanging lamp. Mounting in chrome-plated (CR), grey aluminium painted (G) or nickel-plated satin (NS) metal. The lamp is provided with reflector in anodized aluminium for indirect light emission and diffusers in printed glass, tempered and sand-blasted. Spacer box included. Models 3085.., 3358.. e 3358/1 are provided with telescopic stem.



Suspension. Monture en métal chromé (CR), verni gris aluminium (G) ou nickelé satiné (NS). La lampe est équipée d'un réflecteur pour éclairage indirect et diffuseurs en verre pressé, sablé et trempé. Munie d'entretoise. Les lampes 3085.., 3358.. e 3358/1 sont avec tige télescopique.

Hängelampe. Gestell aus verchromtem (CR), grau lackiertem (G) oder satiniertem Vernickeltem Metall (NS). Der Leuchtkörper ist mit einem Reflektor für indirekte Beleuchtung und Schirmen aus bedrucktem und sandgestrahltem Sicherheitsschirmen ausgestattet. Komplett mit Distanzstück. Modelle 3085.., 3358.. e 3358/1 sind mit Teleskopstiel.

Lámpara de techo. Estructura de metal cromado (CR), pintada gris aluminium (G) o niquelada satinada (NS). El aparato está equipadode reflector para luz indirecta y difusores de cristal grabado, templado y arenado. Dispone de caja separador. Los modelos 3085.., 3358.. e 3358/1 estan con varilla telescópica.

3022..-3022/1.. CR-G-NS	Ø 15 x 36		1x120W (HA) (ES) R7s/80
3085.. CR-G-NS	Ø 15 x 54/66		1x120W (HA) (ES) R7s/80
3358.. CR-G-NS	Ø 23 x 49/66		1x230W (HA) (ES) R7s/115
3358/1.. CR-G-NS	Ø 23 x 49/66		1x70W (MH) Rx7s

   IP40

3022.. - 3022/1.. - 3085.. 3358  3358.. - 3358/1 

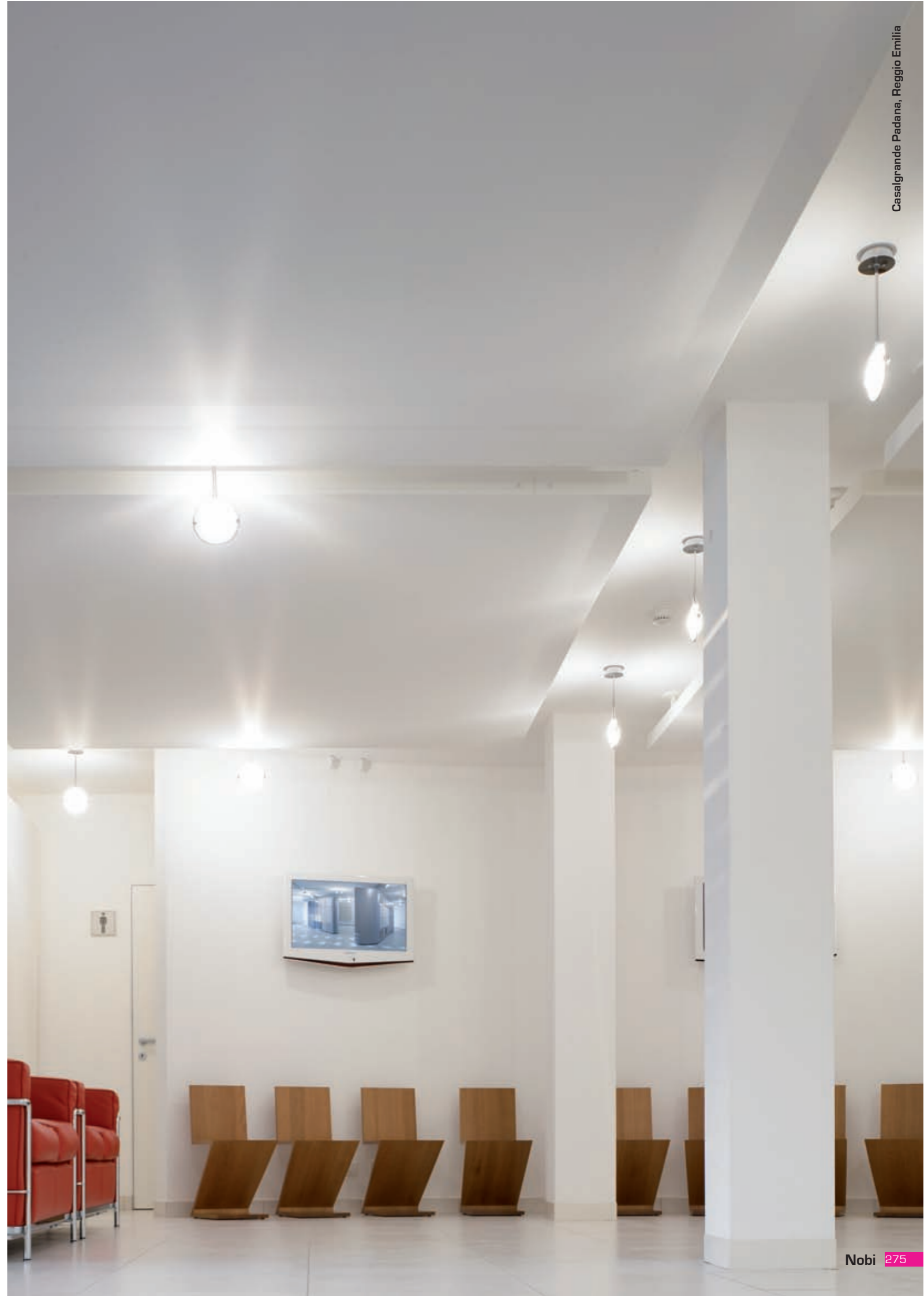
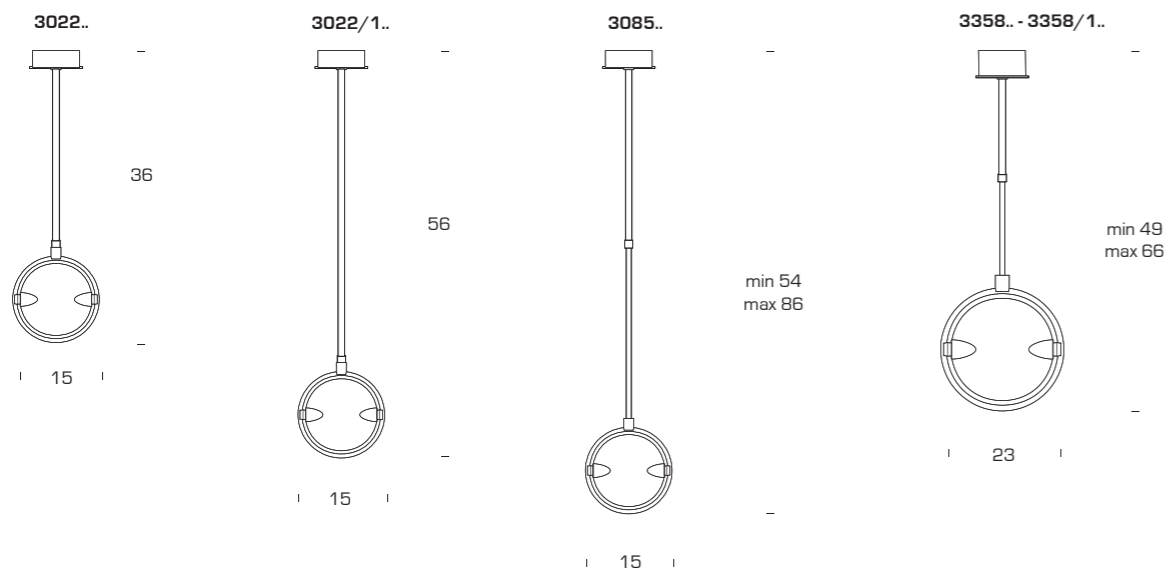

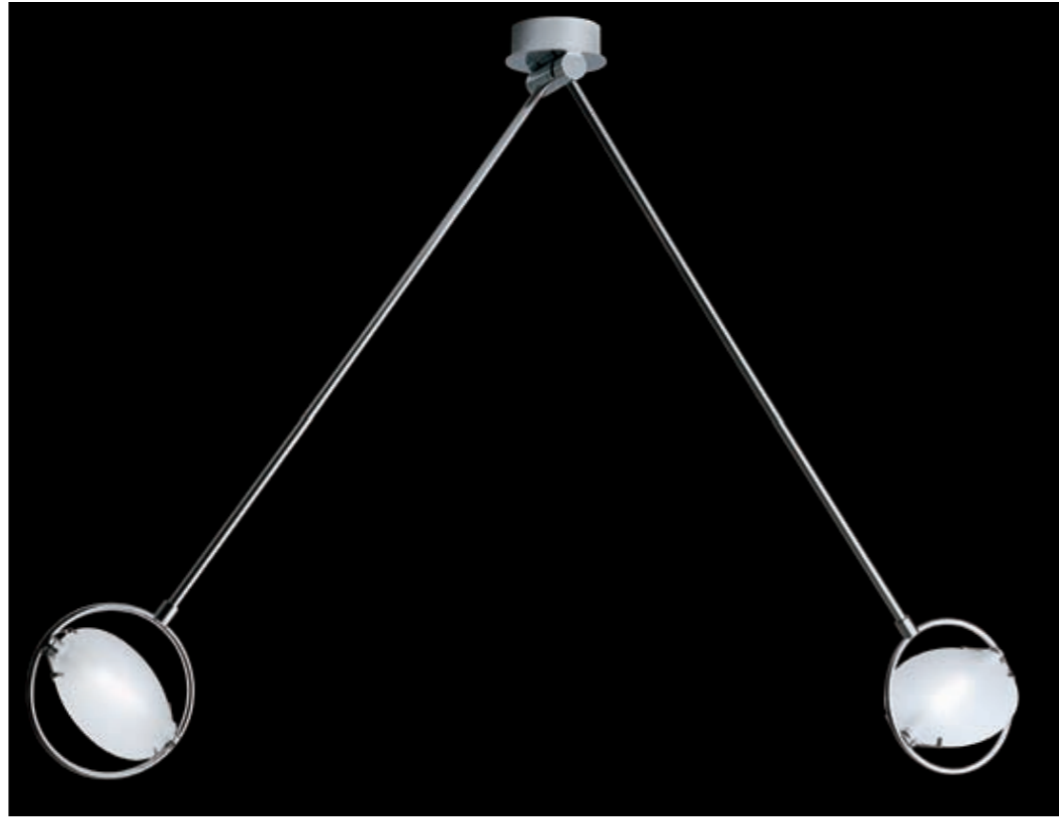

Lampada a sospensione. Montatura con bracci orientabili in metallo cromato (CR), verniciato grigio (G) o nichelato satinato (NS). Diffusori orientabili in vetro stampato, sabbato e temperato. Distanziatore incluso. Nella versione a 4 luci i diffusori possono essere posizionati orizzontalmente oppure verticalmente.

Hanging lamp. Mounting, with adjustable arms, in chrome-plated (CR), grey painted (G) or satin nickel-plated (NS) metal. Adjustable diffusers in pressed, sandblasted, tempered glass. Spacer included. In the version with 4 lights the diffusers can be positioned either horizontally or vertically.

Suspension. Structure à bras orientables en métal chromé (CR), vernis gris (G) ou nickelé satiné (NS). Diffuseurs orientables en verre moulé, sablé et trempé. Entretoise incluse. Dans la version avec 4 lumières les diffuseurs peuvent être placés horizontalement ou verticalement.

Hängelampe. Metallstruktur mit schwenkbaren Armen verchromt (CR), grau lackiert (G) oder vernickeltem gebürstetem (NS). Schwenkbare Schirme aus bedrucktem und sandgestrahltem Sicherheitsglas. Distanzstück inbegriffen. In der Version mit 4 Leuchten können die Schirme wahlweise horizontal oder vertikal angeordnet werden.

Lámpara de techo. Estructura con brazos orientables de metal cromado (CR), pintado gris (G) o niquelado satinado (NS). Difusores orientables de cristal arenado, grabado y templado. Distanziador incluido. En la versión con 4 luces los difusores se pueden colocar horizontal o verticalmente.



R3086S
riflettore in alluminio anodizzato opzionale

R3086S
optional anodized aluminium reflector

R3086S
réflecteur optionnel en aluminium anodisé

R3086S
optionaler Reflektor aus eloxiertem Aluminium

R3086S
opcional reflector de aluminio anodizado

3596. CR - G - NS	24 x 9 x 79	 2x120W (HA)  R7s/80
3597. CR - G - NS	35 x 36 x 65 min (80 max)	 4x120W (HA)  R7s/80

 IP40

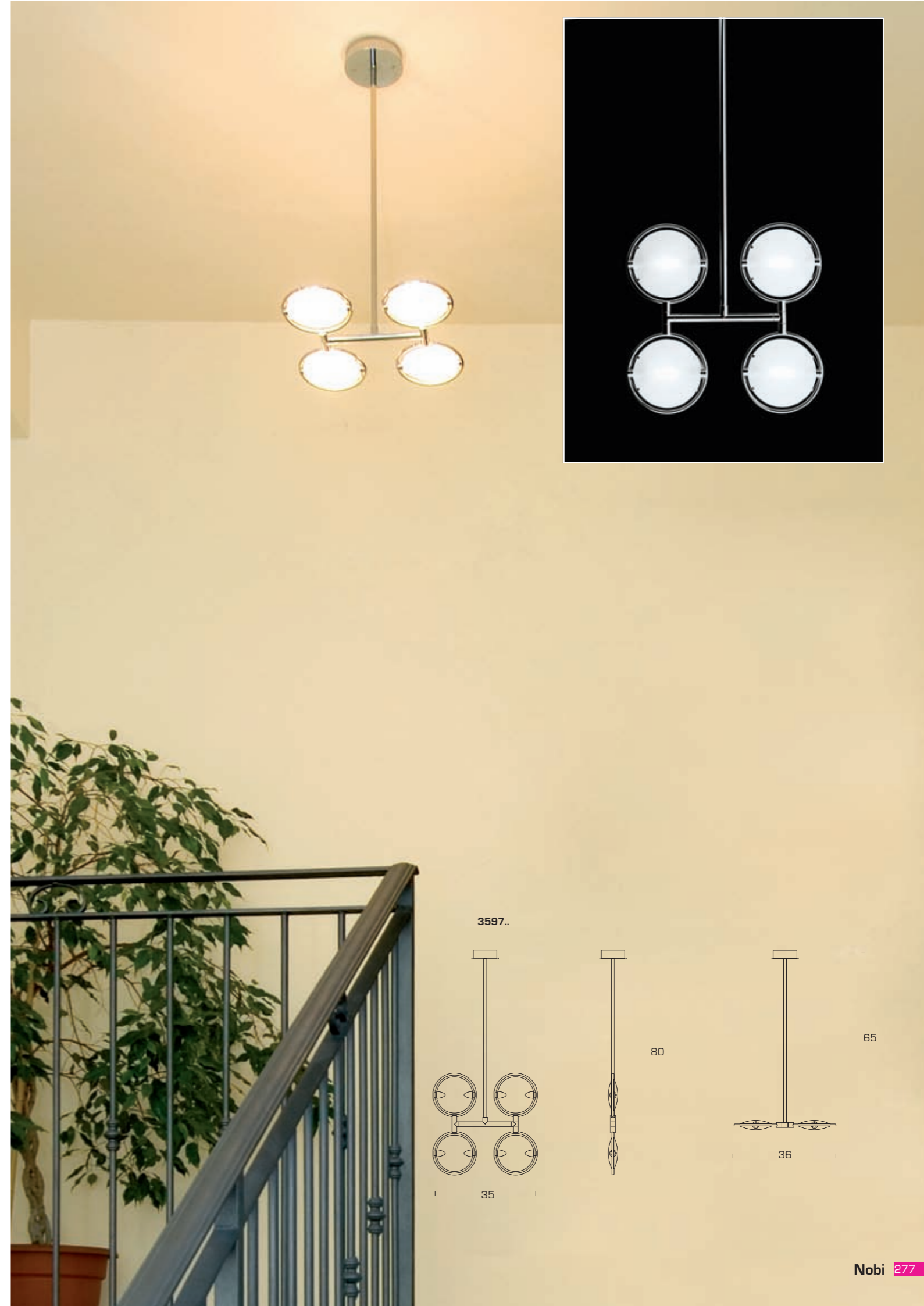
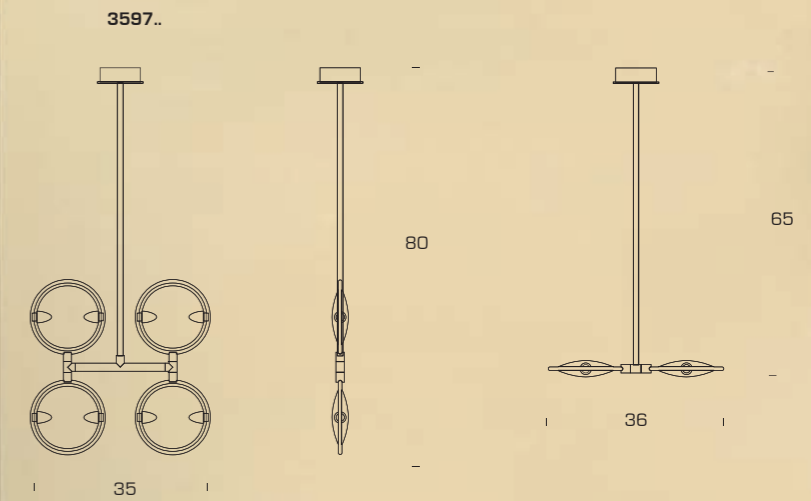
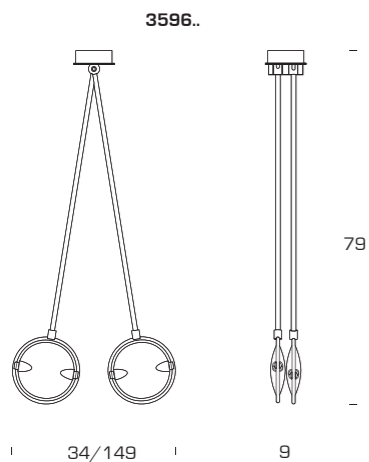

Nobona

Metis 1998



Lampada a sospensione.
Montatura cromata.
Diffusore orientabile in
vetro curvato e sabbato.

Hanging lamp. Chrome-
plated frame. Adjustable
diffuser in curved and
sandblasted glass.

Suspension. Monture
chromée. Diffuseur
orientable en verre
bombé et sablé.

Hängelampe. Verchromtes
Gestell. Verstellbarer Schirm
aus gebogenem
sandgestrahltem Glas.

Lámpara de techo.
Estructura cromada.
Difusor orientable de
cristal curvado y arenado.

3245 Ø 60 x 102 2x100W (HA) **ES** or 2x30W (FL) E27

CE IP20

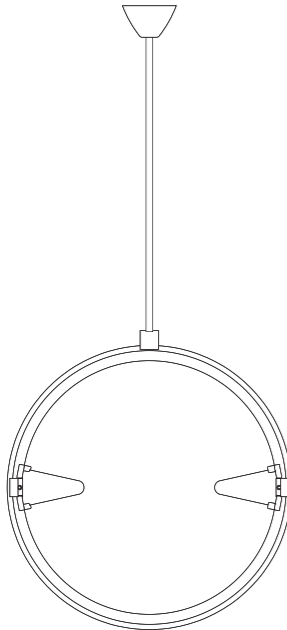

102

60



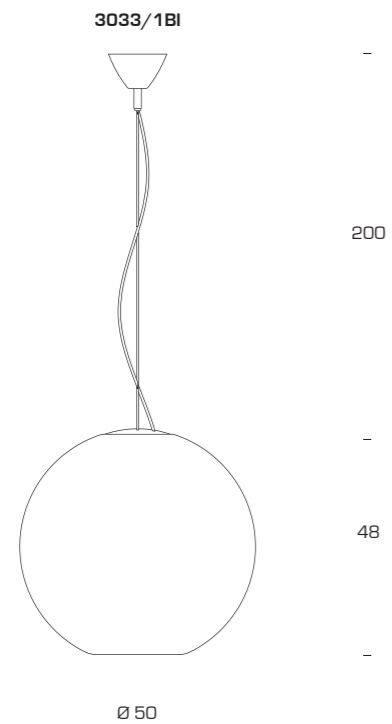

200

48

Ø 50

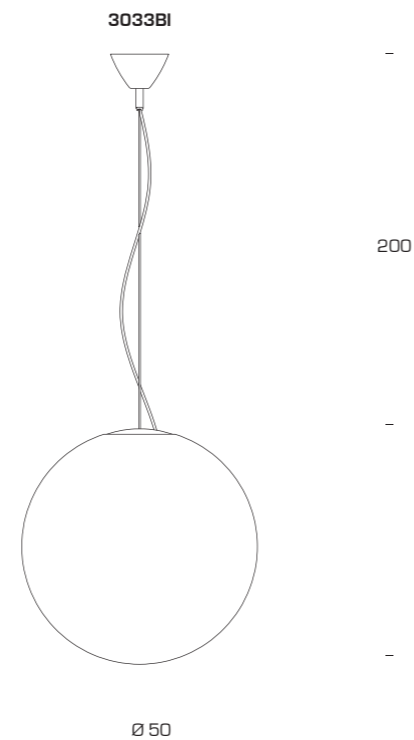

200

Ø 50

Lampada a sospensione con emissione di luce diffusa o doppia emissione di luce (diffusa e concentrata). Rosone cromato. Cavo di alimentazione trasparente. Diffusore in vetro soffiato opalino bianco.

Hanging lamp with diffused light emission or double light emission (diffused and concentrated). Chrome-plated ceiling rose. Transparent feeding cable. Diffuser in white opal blown glass.

Suspension à lumière diffuse ou à double lumière (diffuse et concentrée). Fleuron chromé. Câble d'alimentation transparent. Diffuseur en verre soufflé opalin couleur blanc.

Hängelampe mit gestreutem Licht oder zweifach mit gestreuten und konzentriertem Licht. Verchromte Rosette. Transparentes Netzkabel. Streukörper aus geblasenem weißem Opalglas.

Lámpara de techo de luz difusa o de doble luz (difusa y concentrada). Rosetón cromado. Cable de alimentación transparente. Difusor de cristal soplado blanco opalino.

3033BI	Ø 50 + 200		1x150W (HA) (ES) E27
3033/1BI	Ø 50 x 48 + 200		1x60W (IN) o/ or 1x42W (HA) (ES) E27+ 1x75W PAR30

IP20





Lampada a sospensione. Diffusore e disco inferiore in vetro opalino soffiato bianco satinato. Rosone in metallo verniciato bianco con cavi di sospensione in acciaio e cavo di alimentazione trasparente.

Hanging lamp. Diffuser and lower disk in blown opal glass, white satin. Ceiling rose in white painted metal with steel suspension cables and transparent power cord.

Suspension. Diffuseur et disque inférieur en verre opalin soufflé blanc satiné. Fleuron en métal verni blanc, câbles de suspension en acier, câble d'alimentation transparent.

Hängelampe. Diffusor und untere Scheibe aus mundgeblasenem opalem weißem Glas, satiniert. Rosette aus Metall, weiß lackiert, mit Hängekabeln aus Stahl und transparentem Netzkabel.

Lámpara de techo. Difusor y disco inferior de cristal opalino soplado blanco satinado. Rosetón en metal barnizado blanco con cables de suspensión en acero y cable de alimentación transparente.

3655 Ø 47 x 28 + 150 1x150W (HA) E27

IP20

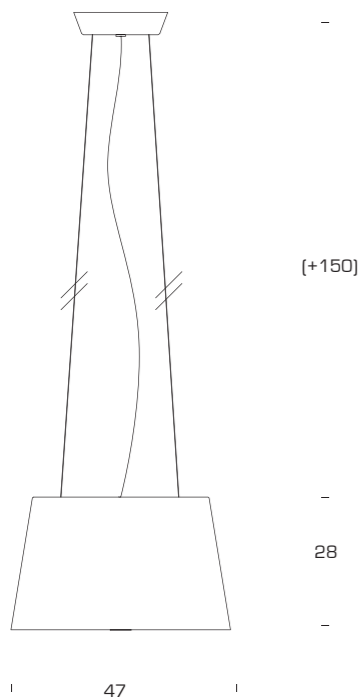

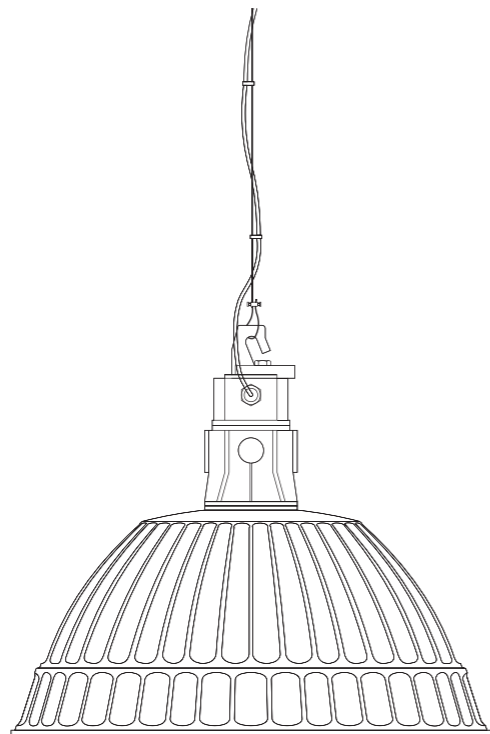

55

200

50

Lampada a sospensione. Riflettore in alluminio sfaccettato e anodizzato. Montatura e gancio a bilanciere in fusione di alluminio. La lampada può essere fornita di un disco in vetro temperato trasparente con anello di chiusura.

Hanging lamp. Reflector in faceted and anodized aluminium. Mounting and balance hook in aluminium casting. The lamp can be provided with a transparent tempered glass disc with closing ring.

Suspension. Reflecteur en aluminium à facettes et anodisé. Monture et crochet à balancier en aluminium coulé. La lampe peut être fournie d'un disque en verre trempé transparent avec anneau de fermeture.

Hängelampe. Riflettor aus facettiertem, eloxiertem Aluminium. Gestell und Kipphebel aus Aluminiumguss. Die Leuchte kann mit einem Hartglas mit Abschlußring geliefert werden.

Lámpara de suspensión. Reflector de aluminio tallado y anodizado. Montura y gancho de balancín de aluminio colado. La lámpara se puede equipar con un disco transparente templado con anilla de cierre.

M5217
 montatura

M5217
 mounting

M5217
 monture

M5217
 Gestell

M5217
 estructura

P5217
 riflettore

P5217
 reflector

P5217
 réflecteur

P5217
 Riflettor

P5217
 reflector

V5217
 disco in vetro opzionale

V5217
 optional glass disc

V5217
 disque en verre optionnel

V5217
 optionale Glasscheibe

V5217
 disco de cristal opcional

M5217 + P5217 Ø 55 x 50 + 200 1x205W (HA) E27 o/or 1x30W (FL) E27

IP20

StudioArt, Arzignano (VI), ph. Paolo Veciani



S1853

Archivio Storico 1954



Morningstar, Milano - progetto speciale

Lampada a sospensione. Montatura in metallo cromato con tige telescopica e cavetto di sostegno all'interno. Diffusore in vetro bianco soffiato e satinato.

Hanging lamp. Chrome-plated metal frame with telescopic stem and internal supporting cable. Diffuser in satin white blown glass.

Suspension. Monture en métal chromé avec tige télescopique et avec câble de soutien à l'intérieur. Diffuseur en verre blanc soufflé et satiné.

Hängelampe. Gestell aus verchromtem Metall mit Teleskopstiel und Stützliste im Innern. Schirm aus weißem, geblasenem Satinglas.

Lámpara de suspensión. Estructura de metal cromado con varilla telescópica y con cable de sujeción en su interior. Difusor de cristal blanco soplado y satinado.

S1853/0	∅ 20 x 85 min (153 max)	1x75W (IN) o/or 1x70W (HA) o/or 1x16W (FL) E27
S1853	∅ 32 x 97 min (163 max)	1x100W (HA) o/or 1x20W (FL) E27
S1853/1	∅ 47 x 80 min (120 max)	1x150W (HA) o/or 1x20W (FL) E27

IP20

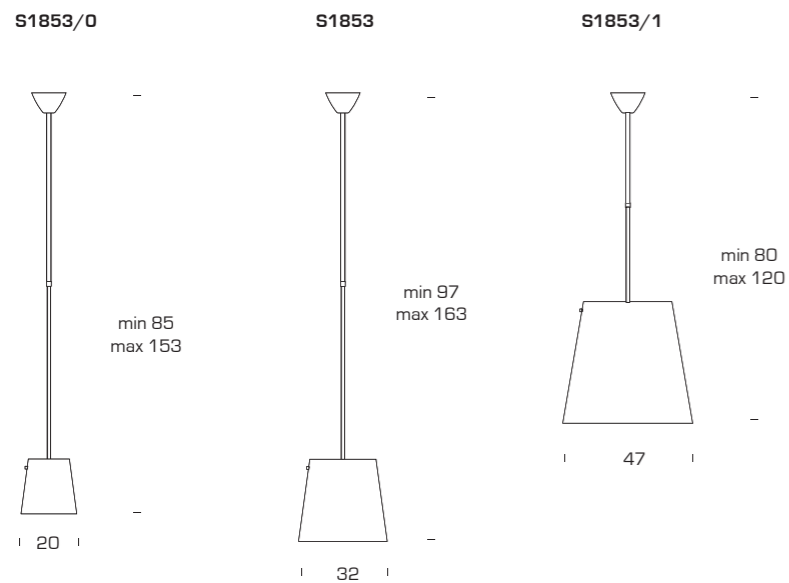

Scintilla AT1S

Livio / Piero Castiglioni 1972



Lampada a sospensione. Struttura cromata (CR) o nichelata satinata (NS). La lampada è provvista di schermi di sicurezza in vetro borosilicato, trasparenti e sabbiati, e un distanziatore per connessioni elettriche. Un riflettore per luce indiretta è disponibile come accessorio.

Suspension lamp. Chrome-plated (CR) or satin nickel-plated (NS) structure. The lamp is provided with safety screens in transparent and sandblasted borosilicate glass and a spacer for electrical connections. A reflector for indirect light emission is available as an accessory.

Suspension. Structure chromé (CR) ou nickelé satiné (NS). La lampe est équipée d'écrans de sécurité en verre borosilicate, transparents et sablés, et d'une entretoise pour les connexions électriques. Un réflecteur pour éclairage indirect est disponible comme accessoire.

Hängelampe. Verchromtes (CR) oder satiniertes vernickeltes (NS) Struktur. Die Lampe ist mit Sicherheitsblenden aus Borosilikatglas geliefert, transparenten und sandgestrahten, und ein Distanzstück für die Stromversorgung. Ein Reflektor für indirekte Beleuchtung ist verfügbar als Zubehör.

Lámpara de techo. Estructura cromada (CR) o niquelada satinada (NS). La lámpara está equipada de pantallas de seguridad en vidrio borosilicato, transparentes y arenados, y un distanciador para conexions eléctricas. Un reflector para luz indirecta está disponible como accesorio.

RAT/F/S150
riflettore per AT1S150..

RAT/F/S150
reflector for AT1S150..

RAT/F/S150
réflecteur pour AT1S150..

RAT/F/S150
Reflektor für AT1S150..

RAT/F/S150
reflector para AT1S150..





RAT/F/S
riflettore per AT1S300..

RAT/F/S
reflector for AT1S300..

RAT/F/S
réflecteur pour AT1S300..

RAT/F/S
Reflektor für AT1S300..

RAT/F/S
reflector para AT1S300..

AT1S150.. CR - NS	16 x 4,5 x 19		1x120W(HA)  R7s/80
AT1S300.. CR - NS	19 x 4,5 x 24		1x230W (HA)  R7s/115

       IP20

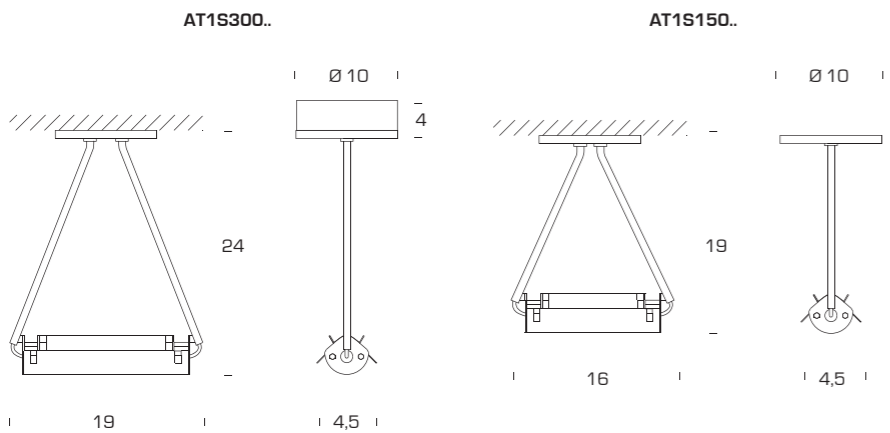

Scintilla AT1SL

Livio / Piero Castiglioni 1972

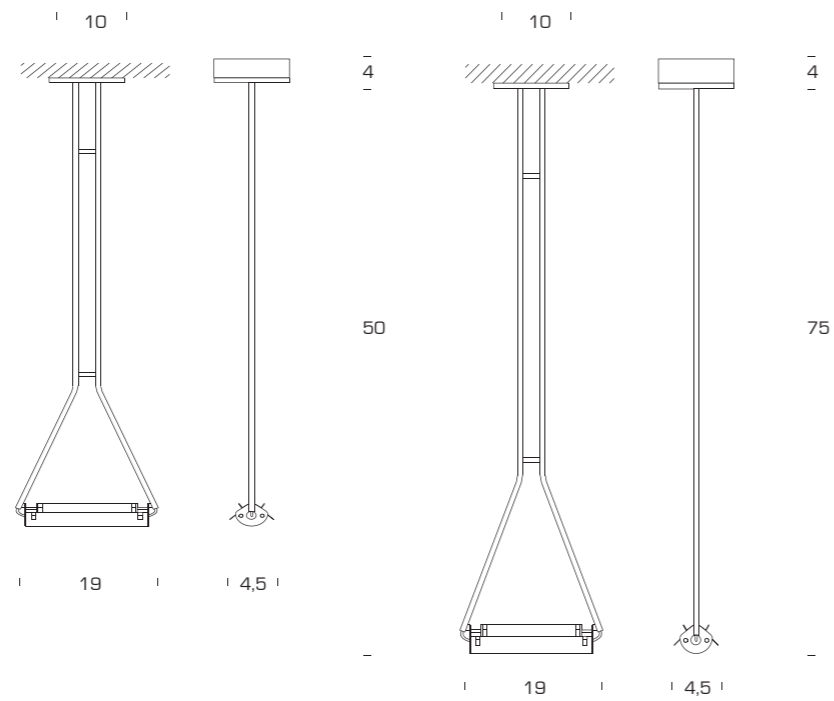

Lampada a sospensione
Struttura portalampara,
piattello, tubetti
passacavo in ottone
o cromati (CR) o nichelati
satinati (NS). La lampada
è provvista di schermi di
sicurezza in vetro
borosilicato, trasparenti e
sabbati, e di un distan-
ziatore per connessioni
elettriche. Un riflettore
per luce indiretta è
disponibile come
accessorio.

RAT/F/S
riflettore

Suspension lamp.
Lamp-holder structure,
plate, cable-holder tubes in
brass, or chrome-plated
(CR) or brass or satin
nickel-plated (NS). The
lamp is provided with
safety screens in
borosilicate glass,
transparent and sand-
blasted, and a spacer for
electrical connections. A
reflector for indirect light
emission is available as an
accessory.

RAT/F/S
reflector

Suspension. Structure
porte lampe, plateau, tubes
porte fils en laiton ou
chromé (CR) ou nickelé
satiné (NS). La lampe est
équipée d'écrans de
sécurité en verre
borosilicate, transparents
et sablés, et d'une
entretoise pour les
connexions électriques. Un
réflecteur pour éclairage
indirect est disponible
comme accessoire

RAT/F/S
réflecteur

Hängelampe. Struktur,
Lampenfassung, Teller,
Kabelrohren
aus Stahl oder verchromt
(CR) oder satinierte
vernickelt (NS) Messing. Die
Lampe ist mit Sicherheits-
blenden aus Borosilikatglas
geliefert, transparenten und
sandgestrahten, und
einem Distanzstück für die
Stromversorgung. Ein
Reflektor für indirekte
Beleuchtung ist verfügbar
als Zubehör.

RAT/F/S
Reflektor

Lámpara de techo.
Estructura portalampara,
platillo, tubos pasacables
de latón o cromado (CR) o
niquelado satinado (NS).
La lámpara está equipada
de pantallas de seguridad
en vidrio borosilicato,
transparentes y arenados,
y de un distanciador para
conexions eléctricas.
Un reflector para luz
indirecta está disponible
como accesorio.

RAT/F/S
reflector

AT1SL50. CR - NS	19 x 4,5 x 50	↔	1x230W(HA) (ES) R7s/115
AT1SL75. CR - NS	19 x 4,5 x 75	↔	1x230W (HA) (ES) R7s/115

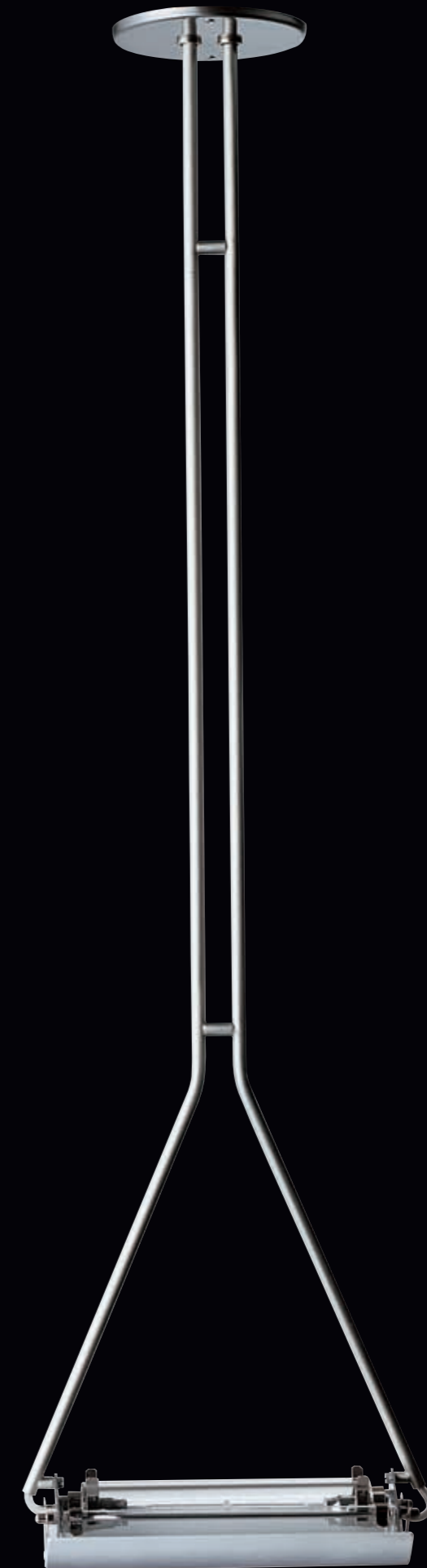

Scintilla BT1S

Livio / Piero Castiglioni 1972

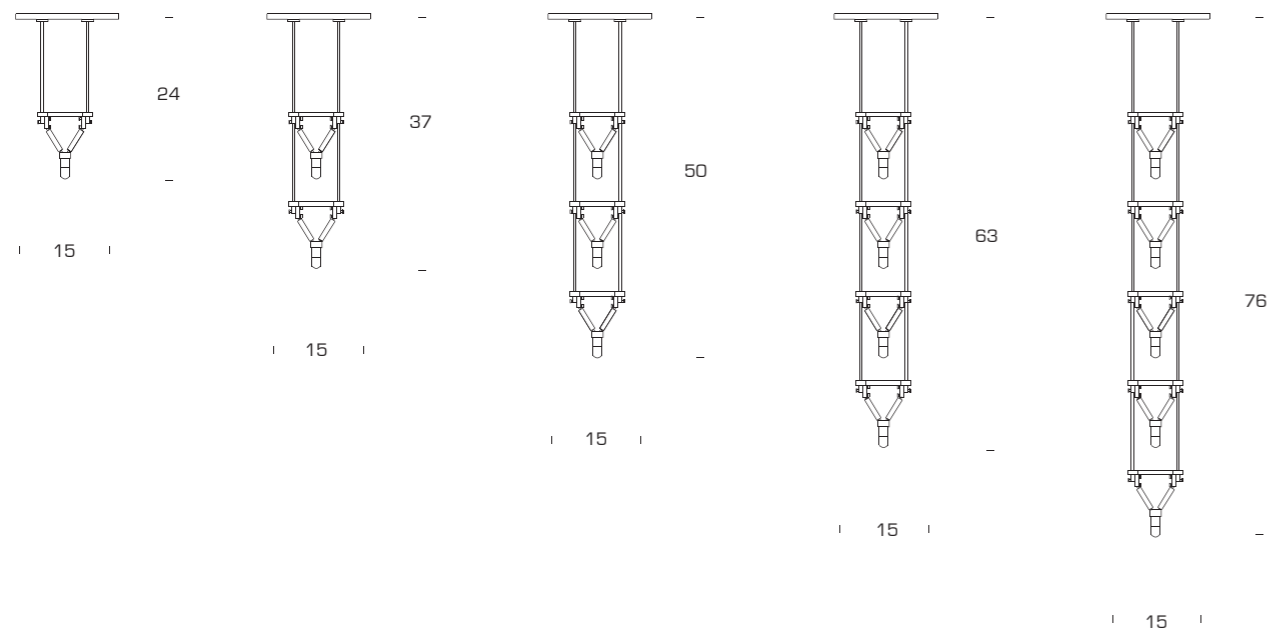

Lampade a sospensione con cascata verticale da 1 a 5 lampadine a bassa tensione. Piattello in acciaio inox, portalampada in steatite, bacchette in rame cromato, distanziatori in vetro borosilicato. Le bacchette in rame consentono di trasferire l'alimentazione a bassa tensione, dal soffitto alla lampadina senza la presenza di cavo elettrico. Trasformatore a richiesta.

Suspension lamp with vertical cascade of from 1 to 5 low-voltage bulbs. Plate in stainless steel, bulb-holder in steatite, stays in chrome-plated copper, spacer in borosilicate glass. The copper stays allow the low voltage power supply to be transferred from the ceiling to the bulb without the presence of electric wires. Transformer upon request.

Suspension à cascade verticale de 1 à 5 ampoules basse tension. Plateau en acier inox, portelampe en stéatite, tiges en cuivre chromé, entretoise en verre borosilicate. Les tiges en cuivre permettent une alimentation basse tension, du plafond à l'ampoule, sans présence de câble électrique. Transformateur sur demande.

Hängelampe mit senkrechter Kaskade mit bis zu 5 Niederspannungsleuchten. Tellerchen aus Edelstahl, Fassung aus Speckstein, Stäbe aus verchromtem Kupfer, Distanzstück aus Borosilikatglas. Durch die Kupferstäbe ist die Niederspannungsversorgung von der Decke bis zur Lampe ohne Netzkabel möglich. Transformator wird auf Wunsch mitgeliefert.

Lámpara de techo con casacada vertical de 1 a 5 bombillas de baja tensión. Platillo de acero inoxidable, portálampara de esteatita, varitas de cobre cromado, distanciador en vidrio borosilicato. Las varitas de cobre permiten llevar la alimentación a baja tensión de el plafón a la bombilla sin la presencia de cable eléctrico. Transformador opcional.

BT1S50/T	Ø 15 x 24	⇒	1x35W (ES) o/or 1x50W 12V (HA) GY6.35
BT2S50/T	Ø 15 x 37	⇒	2x35W (ES) o/or 2x50W 12V (HA) GY6.35
BT3S50/T	Ø 15 x 50	⇒	3x35W (ES) o/or 3x50W 12V (HA) GY6.35
BT4S50/T	Ø 15 x 63	⇒	4x35W (ES) o/or 4x50W 12V (HA) GY6.35
BT5S50/T	Ø 15 x 76	⇒	5x35W (ES) o/or 5x50W 12V (HA) GY6.35

CE IP20



Scintilla Sommatoria

Livio / Piero Castiglioni 1972

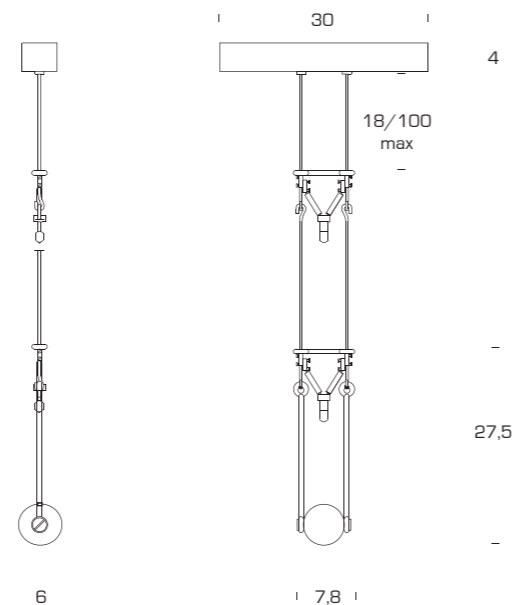

Elementi d'illuminazione modulare a bassa tensione per creazione di gruppi illuminanti a sospensione. Canalina in acciaio inox per ancoraggio a soffitto. Coppia di bacchette in rame cromato di lunghezza massima di 1 metro (da specificare all'ordine). Distanziatori in vetro borosilicato. Sfera terminante in ottone cromato per assicurare il contatto elettrico. Le bacchette in rame consentono di portare l'alimentazione a bassa tensione dalla canalina alle lampadine, senza la presenza di cavo elettrico. Possibilità di montare massimo 12 punti luce. Trasformatore fornito a richiesta.

BTSOMM/EB
elemento base con 1 punto luce
BTSOMM/SU
punto luce supplementare

BTSOMM/EB	49,5 / 131,5	⇒	1x20W 12V [HA] (ES) G4
BTSOMM/SU	18 / 100	⇒	1x20W 12V [HA] (ES) G4

CE Classe II IP20

Low-voltage modular elements for creating suspended lighting groups. Conduits in stainless steel for fixing to ceiling. Pairs of stays in chrome-plated copper of maximum length one metre. Spacers in borosilicate glass. Sphere terminating in chrome-plated brass to guarantee electrical contact. The copper stays allow the low voltage power supply to be transferred from the conduit to the bulbs without the presence of electric wires. Possibility of mounting up to 12 light points. Transformer supplied upon request.

BTSOMM/EB
basic element with 1 light point
BTSOMM/SU
supplementary light point

Éléments d'éclairage modulaire à basse tension pour la création de groupes d'éclairage à suspension. Passe-fil en acier inox pour ancrage au plafond. Paire de tiges en cuivre chromé d'une longueur maximum d'un mètre. Entretoises en verre borosilicate. Sphère terminale en laiton chromé pour assurer le contact électrique. Les tiges en cuivre permettent d'amener l'alimentation basse tension du passe-fil aux ampoules sans la présence de câble électrique. Possibilité de monter un maximum de 12 points d'éclairage. Transformateur fourni sur demande.

BTSOMM/EB
élément base avec 1 point d'éclairage
BTSOMM/SU
point lumière supplémentaire

Elemente für Modularbeleuchtung mit Niederspannung für Hängebeleuchtungssysteme. Edelstahlrohr zur Verankerung an der Decke. 2 Kupferstäbe, verchromt, max. Länge ein Meter. Distanzstücke aus Borosilikatglas. Rundes Endstück aus Kupfer, verchromt, zur Gewährleistung des elektrischen Kontaktes. Durch die Kupferstäbe ist die Niederspannungsversorgung vom Rohr bis zu den Lampen ohne Netzkabel möglich. Anbringung von bis zu 12 Lichtpunkte möglich. Transformator kann auf Wunsch mitgeliefert werden.

BTSOMM/EB
Grundelement mit 1 Leuchte
BTSOMM/SU
zusätzlicher Lichtpunkt

Elementos de iluminación modular de baja tensión para creaciones de grupos de iluminación en suspensión. Canal de acero inoxidable para anclaje en techo. Pareja de varitas de cobre cromado de longitud máxima de un metro. Distanciadores de cristal borosilicato. Esfera con terminación de latón cromado para asegurar el contacto eléctrico. Las varitas de cobre permiten llevar la alimentación de baja tensión del canal a las bombillas sin cable eléctrico. Posibilidad de montar como máximo 12 puntos de luz. Transformador opcional.

BTSOMM/EB
elemento base con 1 punto de luz
BTSOMM/SU
punto de luz suplementario

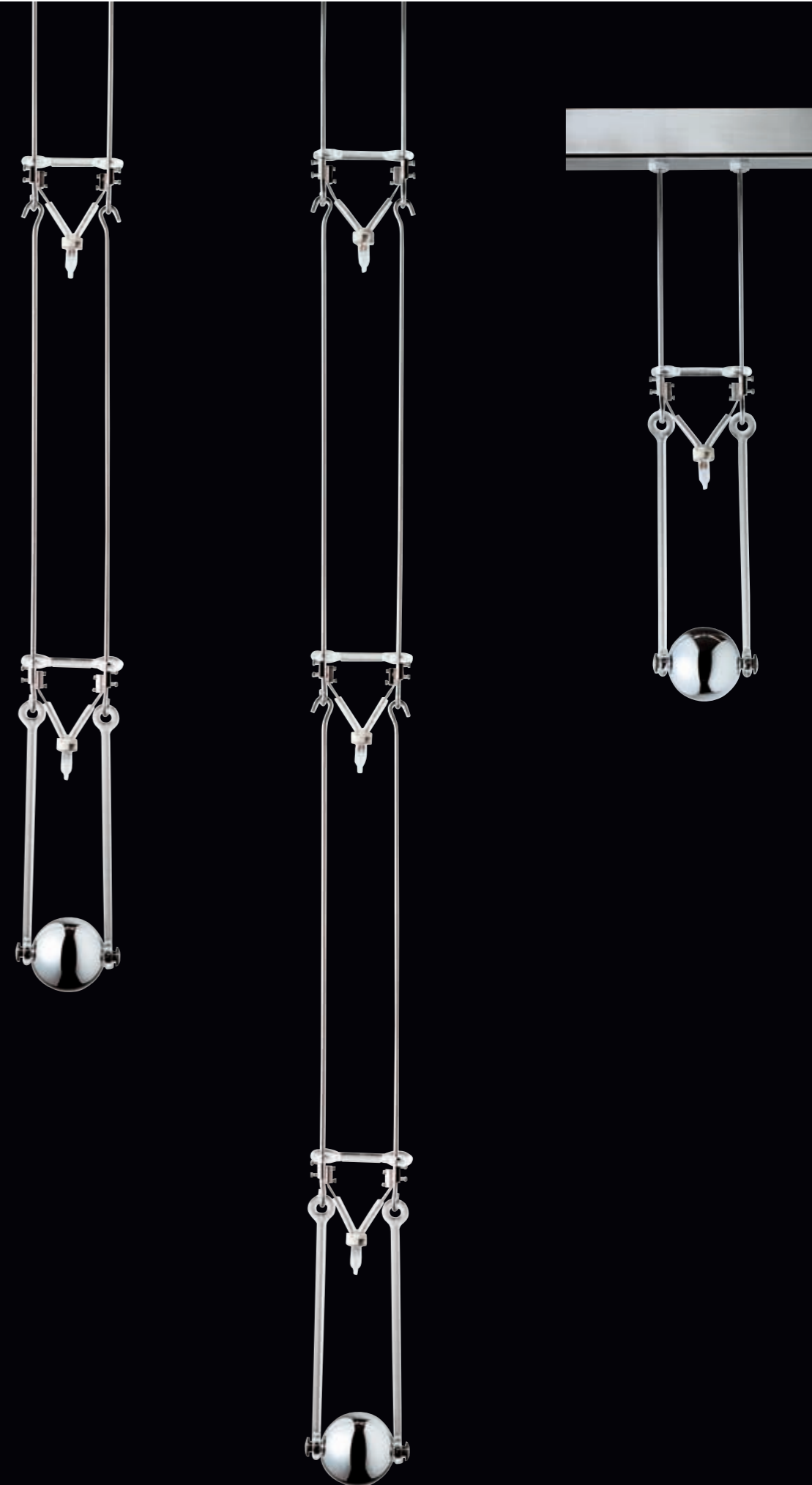

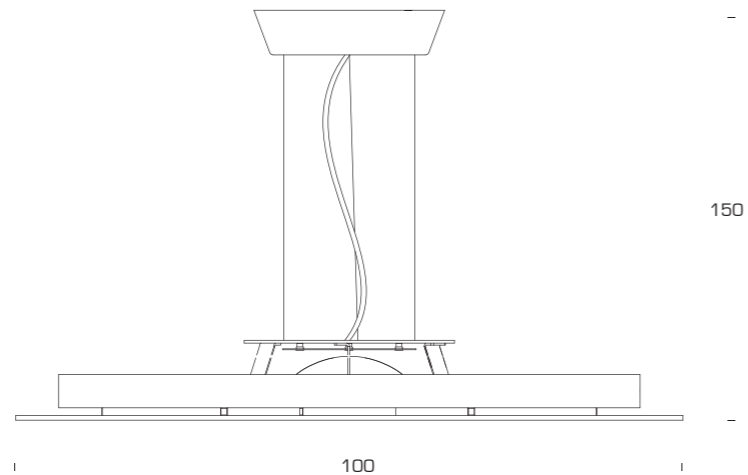

Lampada a sospensione. Montatura in metallo verniciato a polvere epossodica bianco opaco con cavi di sospensione in acciaio regolabili e cavo di alimentazione trasparente. Disco diffusore in vetro extra chiaro temperato colore bianco satinato (BS) o rosso satinato (R). Cupola in vetro soffiato colore bianco lucido (BI) o rosso satinato (R).

Suspension lamp. Mounting in matt-white epoxy-powder coated metal with adjustable hanging steel cables and transparent feeding cable. Shade disc in extra clear tempered white satin glass (BS) or red satin (R). Bowl in blown glass colour brilliant white (BI) or red satin (R).

Suspension. Monture en métal verni aux poudres époxydiques blanc opaque avec câbles réglables en acier et câble de alimentation transparent. Disque diffuseur en verre extra clair trempé blanc satiné (BS) ou rouge satiné (R). Coupole en verre soufflé blanc poli (BI) ou rouge satiné (R).

Hängelampe. Gestell aus mattweißem epoxydlackiertem Metall mit regulierbaren Kabeln aus Stahl und transparentem Kabel. Scheibendiffuser aus Hartglas, extrahell, weiß satiniert (R). Kuppel aus geblasenem Glas, weiß poliert (BI) oder rot satiniert (R).

Lámpara de techo. Montura en metal barnizado con polvos de epoxit blanca opaca con cables regulables de acero y cable de alimentacion transparente. Disco difusor de cristal extra claro templado color blanco satinado (BS) o rojo satinado (R). Cúpula de cristal soplado color blanco lúcido (BI) o rojo satinado (R).

Modello comunitario depositato

Design patent pending

Modèle communautaire déposé

Eingetragenes Warenzeichen

Modelo comunitario depositado

M3748
montatura
V3748.. BS - R
diffusore
S3748.. BI - R
cupola

M3748
mounting
V3748.. BS - R
shade
S3748.. BI - R
bowl

M3748
monture
V3748.. BS - R
diffuseur
S3748.. BI - R
coupole

M3748
Gestell
V3748.. BS - R
Schirm
S3748.. BI - R
Kuppel

M3748
montura
V3748.. BS - R
difusor
S3748.. BI - R
cúpula

M3748 ø 100 x 150 3x80W (FL) 2G11

CE IP20 M3748

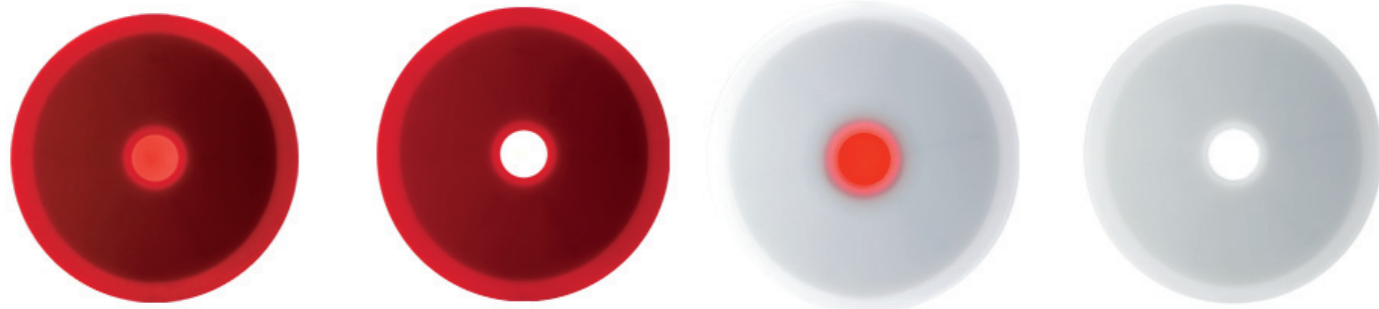



Spiral Tribe

Gabi Peretto 2009

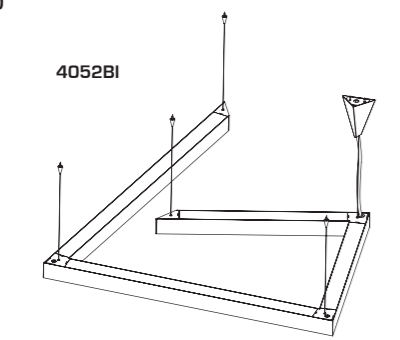

4052BI

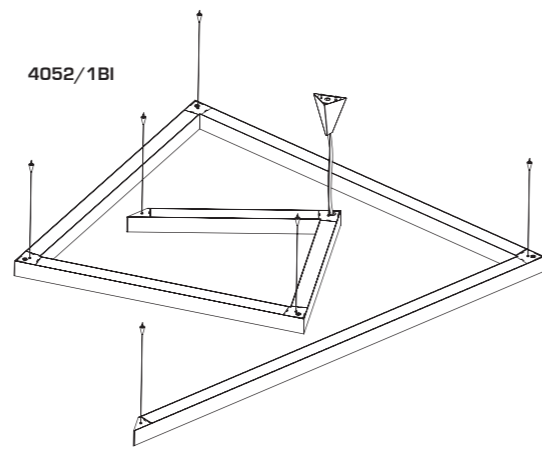
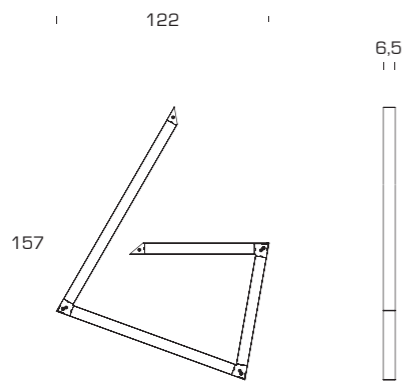

4052/1BI

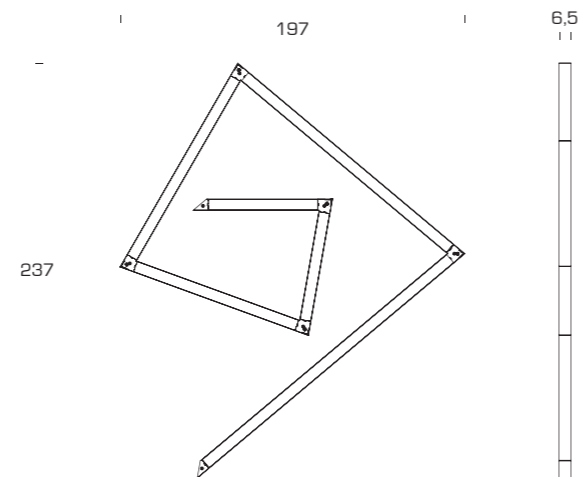



Lampada a sospensione a luce indiretta. Disponibile in due versioni: da 4 o da 6 elementi lineari in alluminio estruso forniti di ottica riflettente per sorgenti fluorescenti T5, e di diffusori trasparenti in policarbonato. Giunti passanti e terminali in pressofusione di alluminio. L'alimentazione elettronica è prevista su ogni elemento e permette la doppia accensione alternata. Cavi di sospensione in acciaio regolabili (max 2.5 m), cavo di alimentazione trasparente. Per il montaggio viene fornita una dima di fissaggio e una livella a bolla.

Suspension lamp with indirect light. Available in two versions: with 4 or 6 extruded aluminum linear elements equipped with aluminum reflecting optics for fluorescent T5 sources and with transparent diffusers. Joints and terminals made of die-cast aluminum. The electronic power supply is conceived to be present on each element and allows double switch with alternate elements. Steel adjustable suspension cables (max 2.5 m), transparent power supply cable. For the assembly, the supply includes a fixing template and a water level.

Suspension à lumière indirecte. Disponible en deux versions : à 4 ou 6 éléments linéaires en aluminium extrudé avec une optique en aluminium réfléchissant pour sources fluorescentes T5 et des diffuseurs transparents. Joints de passage et d'extrémité en aluminium coulé sous pression. L'alimentation électronique est prévue sur chaque élément et permet le double allumage à éléments alternés. Câbles de suspension en acier réglables (max. 2.5 m), câble d'alimentation transparent. Pour le montage, on fournit un dispositif mécanique de fixation et un niveau à bulle d'air.

Pendelleuchte mit indirekter Lichtverteilung. In zwei Versionen verfügbar: mit 4 oder 6 linearen extrudierten Aluminiumelementen mit Reflektoroptik für T5 Leuchtstofflampe und transparente Diffusorabdeckungen aus Polycarbonat. Verbinder und Endkappen aus Aluminiumdruckguß. Jedes Lichtelement ist mit einem EVG ausgestattet und somit 2-fach schaltbar. Höhenverstellbare Stahlseilabhängung (max. 2,5 m). Transparente Zuleitung. Für die Montage wird eine Schablone und eine Wasserwaage mitgeliefert.

Lámpara de techo de luz indirecta. Disponible en dos versiones: de 4 o 6 elementos lineales de aluminio extrudido equipados con óptica de aluminio reflectante para fuentes fluorescentes T5 y con difusores transparentes. Juntas pasantes y terminales de aluminio moldeado a presión. La alimentación electrónica se ha previsto en cada elemento y permite el doble encendido de elementos alternados. Cables colgados de acero ajustables (máximo 2,5 m); cable de alimentación transparente. Para el montaje se entrega un patrón de fijación y un nivel de burbuja.

4052BI	6,5 x 122 x 157 + 250	 2x24W (FL) + 2x39W (FL) G5
4052/1BI	6,5 x 197 x 237 + 250	 2x24W (FL) + 2x39W (FL) + 1x54W (FL) + 1x80W (FL) G5

CE IP20



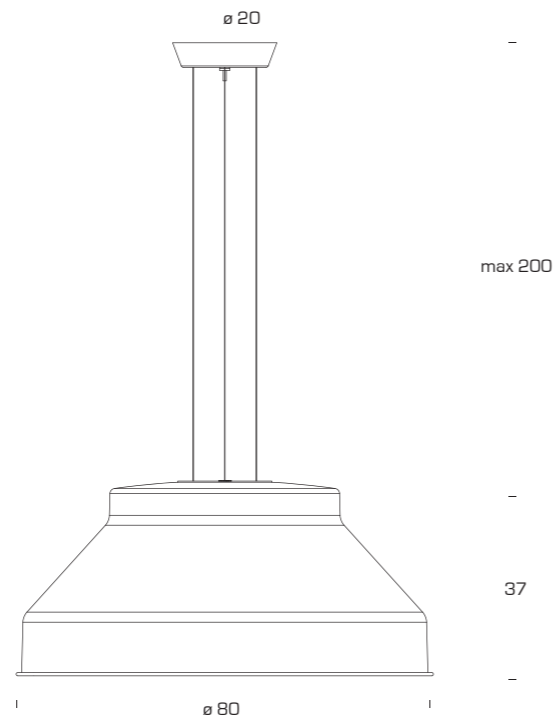



Lampada a sospensione. Diffusore in vetroresina, disco inferiore decorato con grafica serigrafata disponibile in due versioni: floreale (FL) e futurista (FU). Rosone cromato con cavi di sospensione in acciaio regolabili che consentono di montare la lampada anche inclinata (max 20°). Cavo di alimentazione trasparente. Doppia emissione luminosa: diretta verso il basso e diffusa fluorescente. Alimentazione elettronica multipower inclusa nel diffusore. Doppia accensione. A richiesta decori personalizzati.

Suspension lamp. Diffuser in silk-screen printed fiberglass reinforced plastics available in two versions: floral (FL) and futuristic (FU). Chrome-plated rose equipped with three steel suspension cables allowing the lamp to be mounted even in a tilted position (max 20°). Transparent power supply cable. Double light emission: direct downwards and diffused fluorescent. Electronic multipower supply system included in the diffuser. Double activation. Upon request customized decorations.

Suspension. Diffuseur en fibres de verre décoré avec une sérigraphie disponible en deux versions: florale (FL) et futuriste (FU). Rosace chromée pourvue de trois câbles de suspension en acier permettant de monter la lampe même inclinée (max 20°). Câble d'alimentation transparent. Double émission lumineuse: directe vers le bas et diffuse fluorescente. Alimentation électronique multipower incluse dans le diffuseur. Double allumage. À la demande, décorations personnalisées.

Pendelleuchte. Diffusor-scheibe aus Kunststoff mit Siebdruck-Grafik. Verfügbar in zwei Versionen: Blumenmuster (FL) und futuristisches Design (FU). Verchromte Rosette mit regulierbarer 3-fach Stahlseilbhängung, welche es ermöglicht, eine Leuchte auch geneigt aufzuhängen (max 20°). Transparente Zuleitung. Zwei Lichtquellen: downlight und diffuses Licht durch Kompaktleuchtstofflampe. Inklusive Multiwatt EVG 2-fach Schaltbar. Auf Anfrage persönlich gestaltete Dekoration.

Lámpara de techo. Difusor de fibra de vidrio decorado con gráfica serigrafada disponible en dos versiones: floral (FL) y futurista (FU). Florón cromado equipado con tres cables de colgar de acero, que permiten montar la lámpara también inclinada (20°). Cable de alimentación transparente. Doble emisión luminosa: dirigida hacia abajo y difundida fluorescente. Alimentación electrónica multipower incluida en el difusor. Encendido doble. A petición de los interesados, decoraciones personalizables.

4094.. FL - FU	ø 80 x 37,5 + 200	  1x100W (HA) o/or 1x15W (FL) PAR30 E27 + 1x26/32/42W GX24q-3/4 (FL)
4095.. FL - FU	ø 80 x 37,5 + 200	 1x100W (HA) o/or 1x15W (FL) PAR30 E27 + LED RGB

CE IP20



Time 20:30

Studio Parisotto / Formenton 2006



Lampada a sospensione con doppia emissione di luce (diffusa e concentrata). Struttura in alluminio estruso anodizzato satinato (A) o anodizzato nero opaco (N). Diffusori in vetro bianco satinato (BI) o arancione ambra satinato (AM). Cavetti di sospensione in acciaio. Trasformatori inclusi.

Suspension lamp with double light emission, diffused and concentrated. Structure in anodized satin-finish extruded aluminium (A) or anodized matt black (N). Shades in white satin-finish glass (BI) or amber/orange satin-finish (AM). Steel suspension cables. Transformers included.

Suspension à double éclairage (diffus et concentré). Structure en aluminium extrudé anodisé satiné (A) ou anodisé noir opaque (N). Diffuseurs en verre blanc satiné (BI) ou orange/ambre satiné (AM). Câbles pour suspension en acier. Transformateurs inclus.

Hängelampe mit Doppelschaltung (diffuse und konzentrierte) Beleuchtung. Struktur aus Aluminium, stranggepresst, eloxiert, satiniert (A) oder eloxiert mattschwarz (N). Schirme aus weißem satiniertem (BI) oder bernsteinfarben satiniertem (AM) Glas. Hängekabel aus Stahl. Trafo werden mitgeliefert.

Lámpara de techo con doble luz (difusa y concentrada). Estructura de aluminio extrudido anodizado satinado (A) o anodizado negro opaco (N). Difusores de cristal blanco satinado (BI) o anaranjado ámbar satinado (AM). Cables para suspensión de acero. Transformadors incluidos.

M5528.. A - N + V5528.. AM - BI 9 x 45 + 200  1x18W (FL) 2G11 + 1x20W (HA) GU4

 IP20

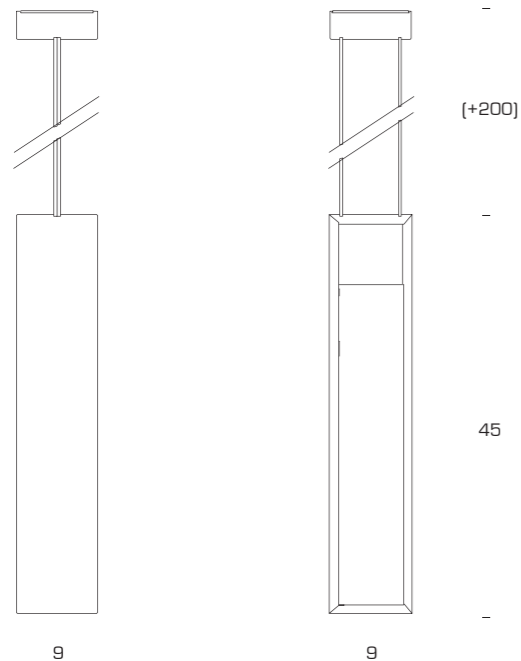



Lampada a sospensione a luce diffusa o a doppia emissione di luce (diffusa e concentrata). Diffusore in vetro soffiato opalino bianco acidato. Rosone cromato. Cavo di alimentazione trasparente.

Hanging lamp with diffused or double light emission (diffused and concentrated). Diffuser in white opal blown acid-etched glass. Chrome-plated ceiling rose. Transparent feeding cable.

Suspension à lumière diffuse ou à double lumière (diffuse et concentrée). Diffuseur en verre soufflé opalin blanc traité à l'acide. Fleuron chromé. Câble d'alimentation transparent.

Hängelampem it gestreutem Licht oder zweifach mit diffusem und konzentriertem Licht. Schirm aus weißem, geblasenem Ätztglas. Verchromte Rosette. Transparentes Netzkabel.

Lámpara de techo de luz difusa o de doble luz (difusa y concentrada). Difusor de cristal soplado opalino blanco al ácido. Rosetón cromado. Cable de alimentación transparente.

3032	Ø 43 x 60 + 200	1x150W (HA) (ES) E27
3032/1	Ø 43 x 56 + 200	1x60W (IN) o/or 1x42W (HA) (ES) E27 + 1x75W PAR30

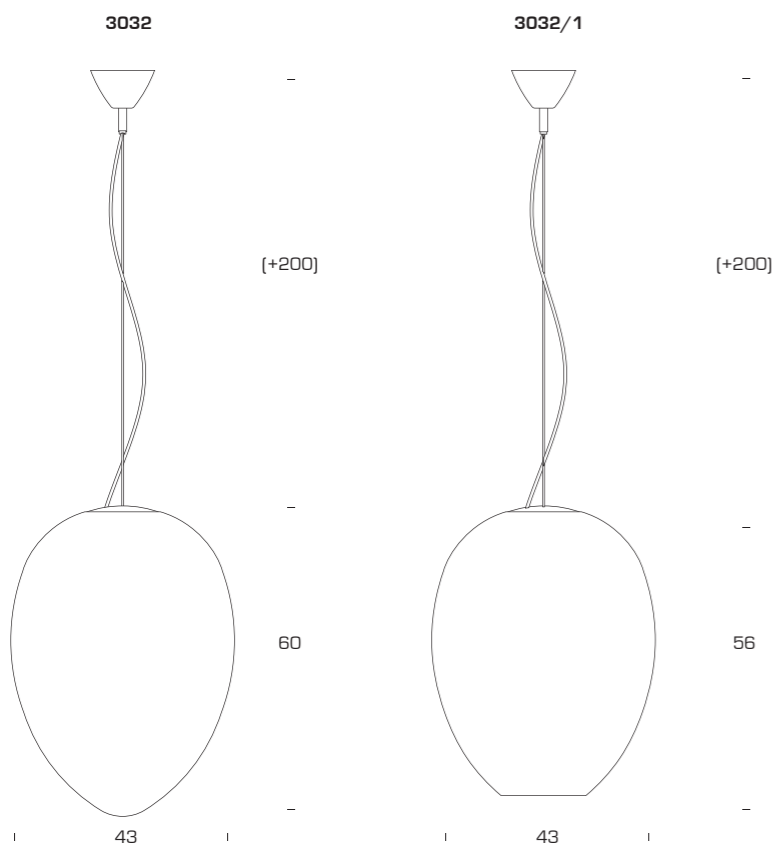







Lampada a sospensione. Diffusore in vetro, spessore 3 mm, curvato, indurito e sabbato. Schermi di sicurezza per lampadina alogena in vetro borosilicato sabbato. Rosone e agganci in alluminio pressofuso. Tiranteria in acciaio. La lampada è disponibile in 5 altezze diverse.

Hanging lamp. Diffuser in tempered, sandblasted, curved glass (3 mm thick). Halogen bulb safety shields in sandblasted borosilicate glass. Die-cast, aluminium ceiling rose and hooks. Brushed and polished steel rods. The lamp is available in 5 heights.

Suspension. Diffuseur en verre, épaisseur 3 mm, bombé, durci et sablé. Ecran de sécurité pour ampoule halogène en verre borosilicate sablé. Rosace et crochets en aluminium moulé sous pression. Tirants en acier. La lampe est disponible en 5 hauteurs différentes.

Hängelampe. Schirm aus 3 mm starkem gebogenem, gehärtetem, satiniertem Glas. Sicherheitsabdeckungen für die Halogenlichtquelle aus Borosilikat-Mattglas. Rosette und Aufhänger aus Pressguss-Aluminium. Gestänge aus Stahl. Die Leuchte ist in 5 Größe erhältlich.

Lámpara de techo. Difusor de cristal de 3 mm de grosor, curvado, endurecido y arenado. Pantallas de seguridad para bombilla halógena de vidrio borosilicato arenado. Rosetón y enganches de aluminio fundido a presión. Tirantes de acero. La lámpara está disponible in 5 tamaños de alto.

2791/..	80 x 60 - 50/70/90/110/130	 1x230W (HA)  R7s/115
2791/1/..	120 x 60 - 50/70/90/110/130	 1x230W (HA)  R7s/115

    IP20

2791/..

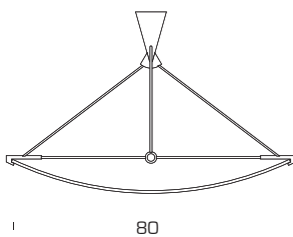

80

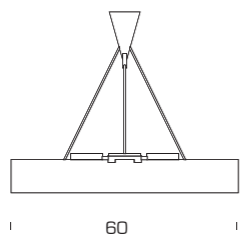

60

50/70/90/
110/130

2791/1/..

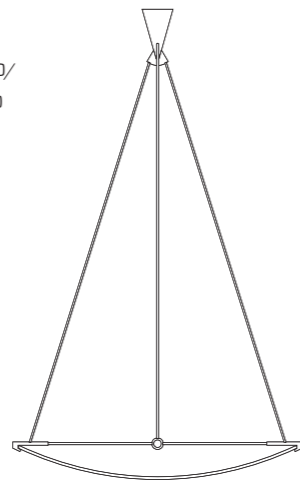

120

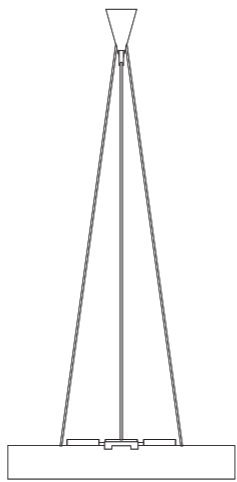

60

50/70/90/
110/130





Lampada a sospensione a 1, 2 oppure 3 luci. Paralume in lamiera d'alluminio piegata e lucidata a specchio o verniciata color bianco (BI). Riflettore interno in alluminio verniciato con speciale patina antiriflesso. Rosone o canalina dello stesso colore del paralume. Cavo di alimentazione trasparente.

Hanging lamp with 1, 2 or 3 lights. Shade of folded aluminium sheet, mirror finish or painted white (BI). Internal reflector of painted aluminium with special anti-glare coating. Ceiling rose or raceway in the same colour as the diffuser. Transparent feeding cable.

Suspension avec 1, 2 ou 3 lumieres. Abat-jour en tôle d'aluminium pliée et polie miroir ou vernie blanc (BI). Réflecteur interne en aluminium verni, effet spécial anti-reflets. Rosace ou conduit de câble de la même couleur de l'abat-jour. Câble d'alimentation transparent.

Hängelampe mit 1, 2 oder 3 Leuchten. Lampenschirm aus gefaltem Aluminiumblech oder eloxiert weiß lackiert (BI). Innerer Reflektor aus Aluminium, mit spezieller blendfreier Beschichtung lackiert. Rosette oder Rohr in dem selben Farben vom Schirm. Transparentes Netzkabel.

Lámpara de techo con 1, 2 o 3 luces. Pantalla en chapa de aluminio plisada y abricantada o barnizada en blanco (BI). Reflector interior de aluminio barnizado con patina especial antirreflectora. Rosetón ou canaleta en lo mismo color de la pantalla. Cable de alimentación transparente.

5546 - 5546BI	24 x 27 x 40 + 150	☞ ☞	1x60W (HA) o/or 1x42W (HA) (ES) E14
5546/2 - 5546/2BI	80 x 24 x 40 + 150	☞ ☞	2x60W (HA) o/or 2x42W (HA) (ES) E14
5546/3 - 5546/3BI	130 x 24 x 40 + 150	☞ ☞	3x60W (HA) o/or 3x42W (HA) (ES) E14

CE IP20

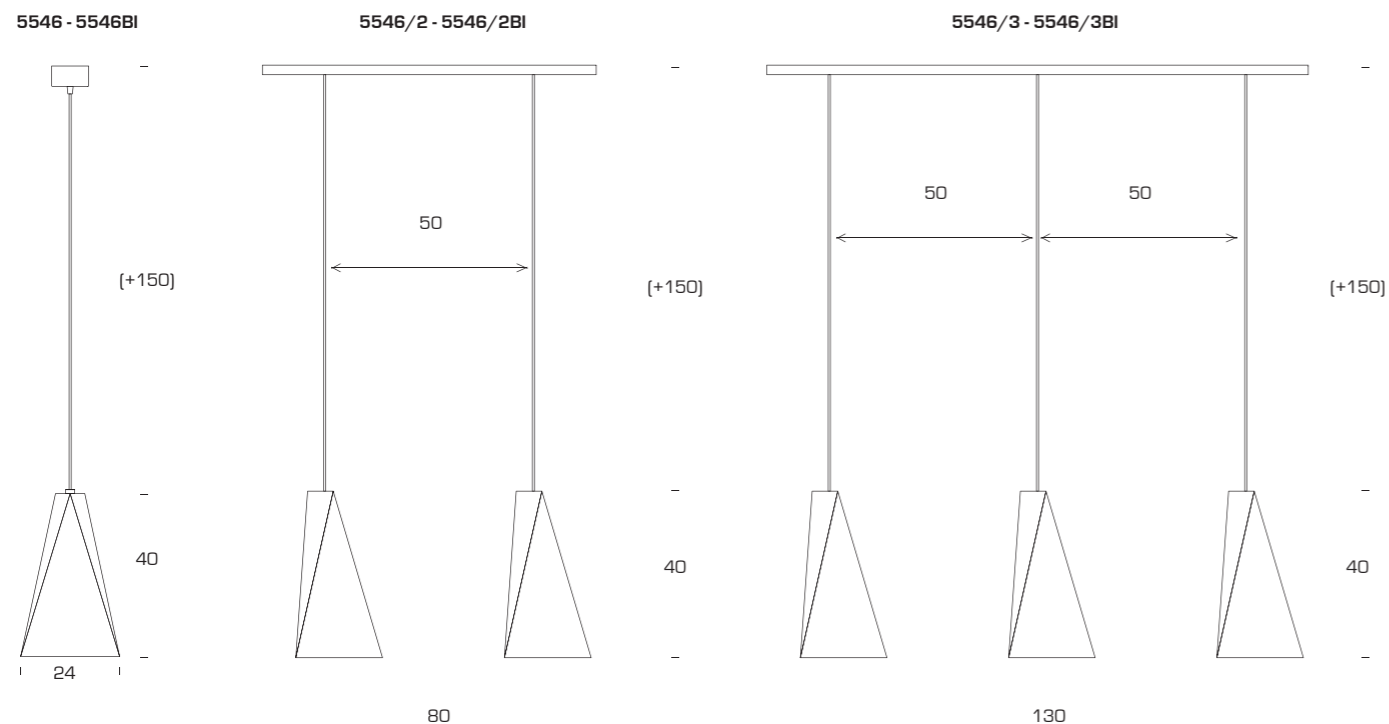



Furniture

Pezzi unici, veri e propri elementi di arredo che contribuiscono a formare lo spirito dei luoghi che li accolgono • A collection of unique and functionally designed elements that help to shape the mood of the environments in which we live • Pièces uniques, véritables éléments fondamentaux d'ameublement qui contribuent à former l'esprit des lieux qui les accueillent • Einzelstücke, fundamentale Möbelemente, die dazu beitragen, den Geist der Räumlichkeiten, die sie aufnehmen, zu bilden • Piezas únicas, elementos fundamentales de decoración que contribuyen formando el espíritu de los lugares que los acogen.

Furnishing accessories

Trasparenze senza tempo che si inseriscono silenziosamente in ambienti anche molto diversi tra loro, grazie a linee purissime e eleganti • Timeless objects that fit unobtrusively into a wide variety of interiors due to their pure and elegant lines • Transparences sans âge qui s'insèrent silencieusement dans des lieux très différents les uns des autres, grâce à des lignes très pures et élégantes • Zeitlose Transparenzen, die sich dank ihrer reinen und eleganten Linien geräuschlos in sehr unterschiedlichen Räumlichkeiten einfügen • Transparencias intemporales que se integran silenciosamente en una amplia variedad de interiores, gracias a sus líneas purísimas y elegantes.

Teso

Renzo Piano 1985

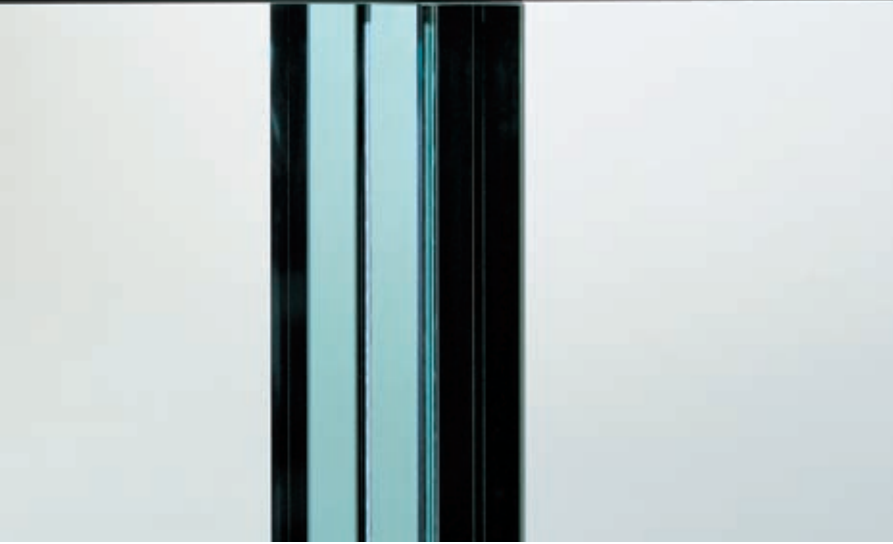

Tavolo. Piano in vetro float stratificato (spessore 25 mm). Gambe in lastre di vetro float stratificato, dello spessore di 38 mm, con scanalature per inserimento di tiranti in metallo. La tensione, grazie all'elevato coefficiente di compressione del vetro, trasforma il tavolo in un monoblocco.

Table. Layered (25 mm thick) float-glass top. Layered (38 mm thick) float-glass sheet legs, grooved to contain metal ties. Thanks to its high glass-compression coefficient, tension makes the table a one-piece structure.

Table. Plateau en verre float stratifié (épaisseur 25 mm). Pieds en plaque de verre float stratifié (épaisseur 38 mm) rainurés pour l'introduction de tirants en métal. Grâce au coefficient de compression élevé du verre, la tension transforme la table en un monobloc.

Tisch. Oberfläche aus geschichtetem Float-Glas, 25 mm stark. Tischbeine aus geschichtetem Float-Glasscheiben, 38 mm stark, mit Aussparungen zum Montieren der Spannstangen aus Metall. Durch den Druck, der durch den hohen Kompressionskoeffizienten ausgeübt wird, wirkt der Tisch wie ein einziger großer Block.

Mesa. Sobre de cristal float estratificado (espesor 25 mm). Patas en láminas de cristal float estratificado (espesor 38 mm) con ranuras para introducir tirantes de metal. La tensión, debido al importante coeficiente de compresión del cristal, transforma la mesa en un sólo bloque.

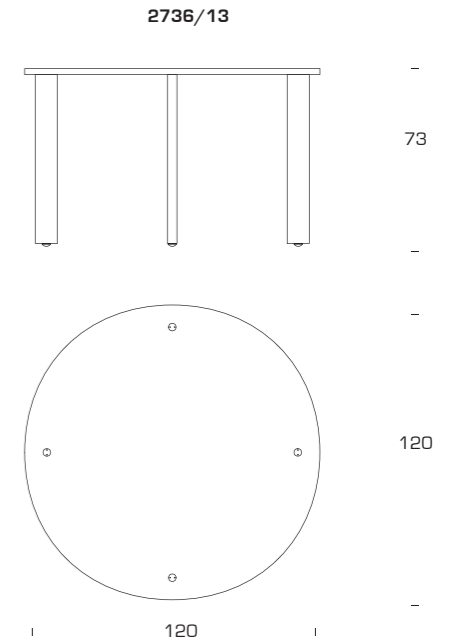
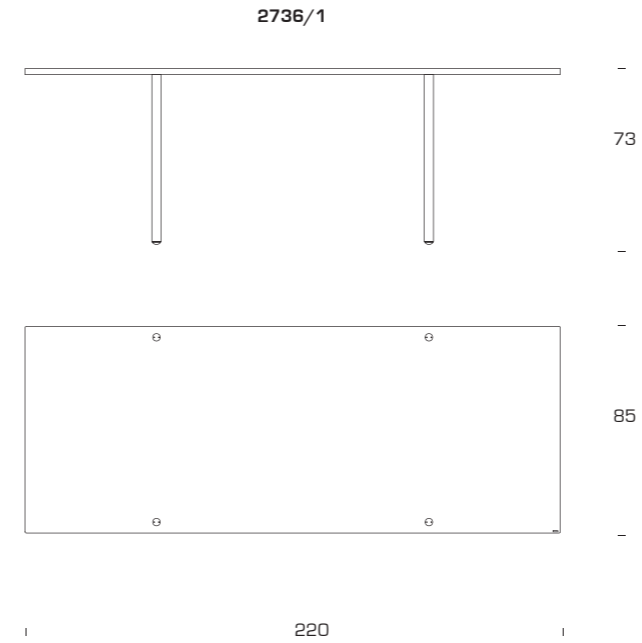

2736/1	220 x 85 x 73
2736/13	∅ 120 x 73



Tour

Gae Aulenti 1993

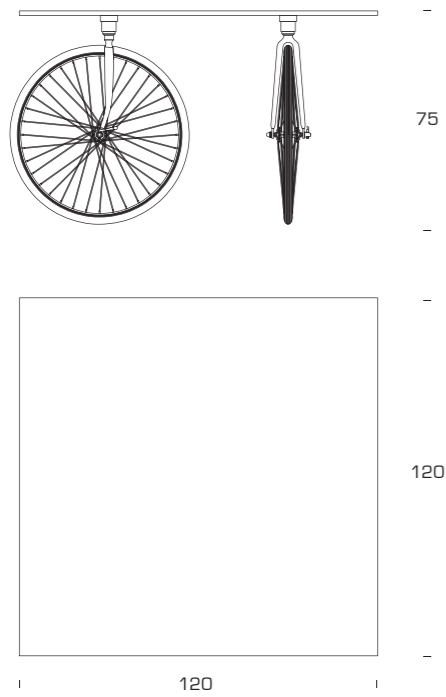

75

120

120

Tavolo. Piano in vetro float molato (spessore 15 mm). Ruote pivotanti fissate al piano mediante quattro piattelli in acciaio inox. Forcelle cromate. Copertoni in gomma piena.

Table. Float ground glass top (15 mm thick). Rotating wheels fixed to the top by four stainless steel plates. Chromium-plated brackets. All-rubber wheels.

Table. Plateau en verre float biseauté, (épaisseur 15 mm). Roues pivotantes fixées au plateau par quatre rondelles en acier inox. Fourches chromées. Pneumatiques en caoutchouc plein.

Tisch. Oberfläche aus geschliffenem Float-Glas (15 mm stark). Die Pivot-Räder sind mittels vier Scheiben aus Edelstahl an der Tischfläche befestigt. Verchromte Gabeln. Die Reifendecken sind aus Vollgummi.

Mesa. Sobre de cristal float biselado (espesor 15 mm). Ruedas pivotantes fijadas en el sobre con cuatro platos de acero inoxidable. Horquillas cromadas. Cubiertas de caucho denso.

3005

120 x 120 x 75

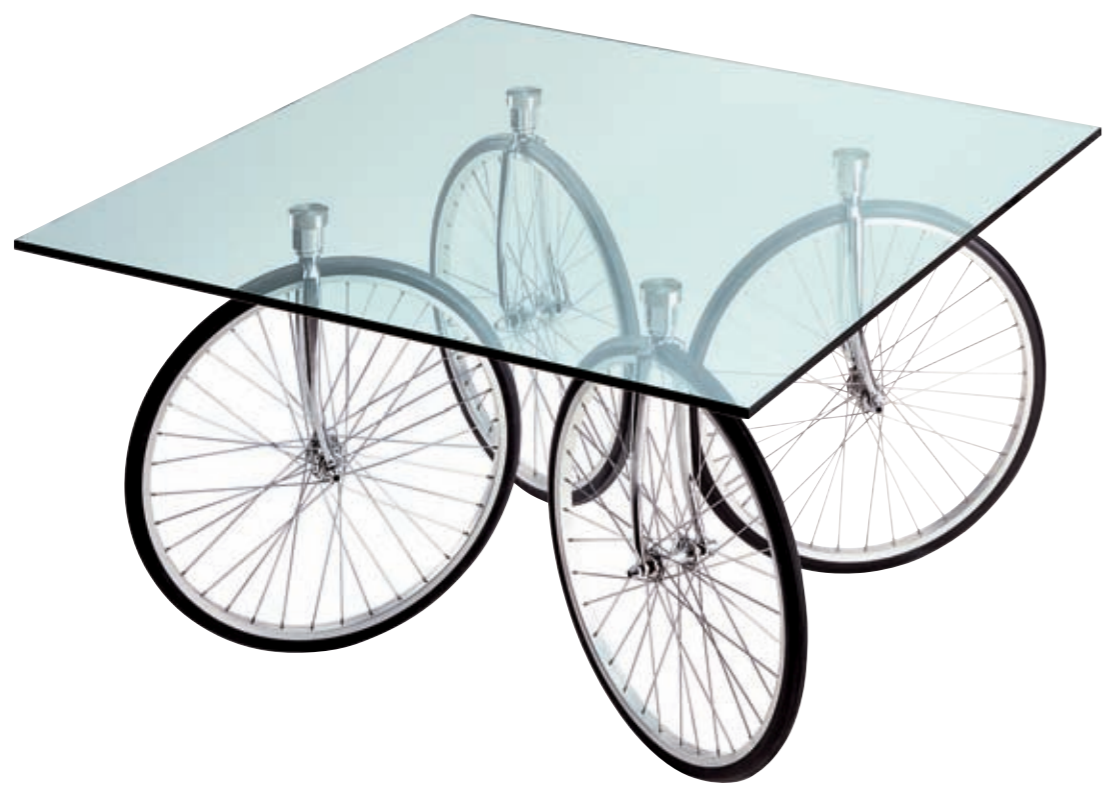

2633

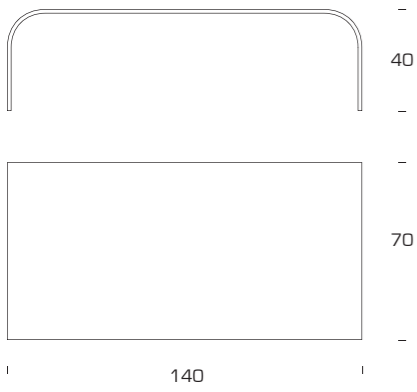

2633/1

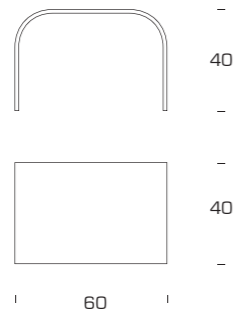

2633/2

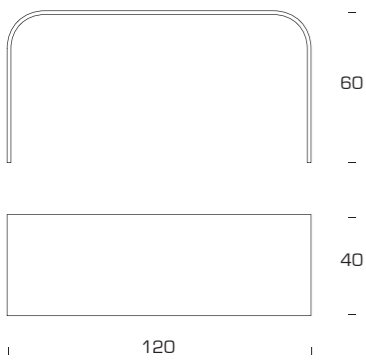

2633/4

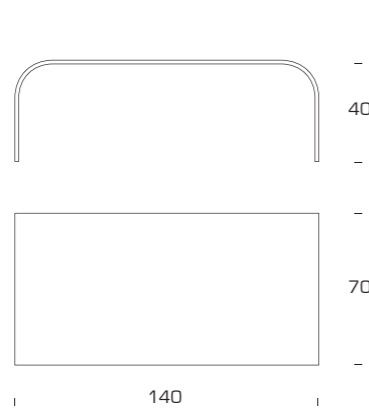

Tavolino in vetro float dello spessore di 15 mm, curvato e molato.

Coffee table. Curved and ground float-glass (15 mm thick).

Table basse en verre float (épaisseur 15 mm), courbé et biseauté.

Kleiner Tisch aus Float-Glas (15 mm stark), gebogen und geschliffen.

Mesita de cristal float (espesor 15 mm), curvado y biselado.

2633	140 x 70 x 40
2633/1	60 x 40 x 40
2633/2	120 x 40 x 60
2633/4	120 x 60 x 40

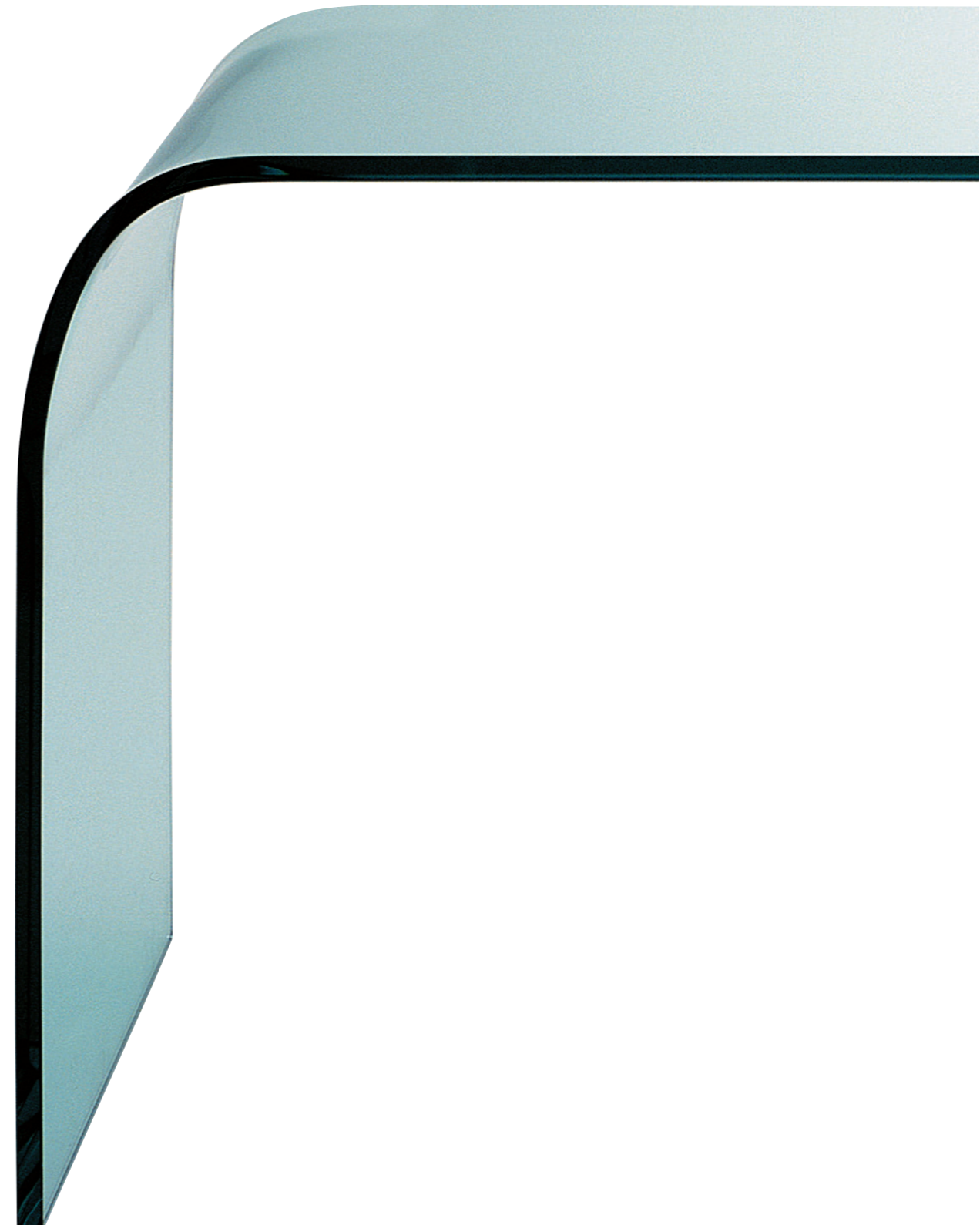

Tavolino 1932

Gio Ponti 1932

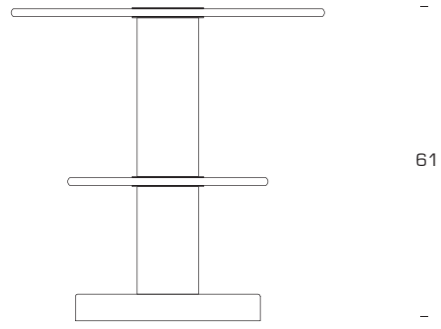

61

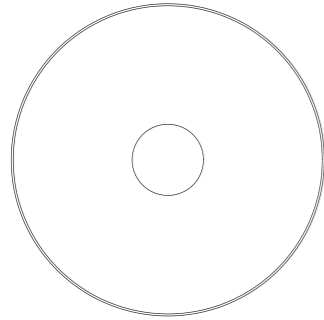

61

Tavolino con due dischi in vetro float dello spessore di 15 mm. Struttura in ottone nichelato e spazzolato.

Occasional table with two 15 mm thick float-glass disks. Structure in polished nickel-plated brass.

Table basse avec deux disques en verre float, épaisseur 15 mm. Structure en laiton nickelé et brossé.

Kleiner Tisch mit zwei runden Platten aus Float-Glas, 15 mm stark. Struktur aus geglänztem, vernickeltem Messing.

Mesita con dos discos de cristal float, espesor 15 mm. Estructura de latón niquelado y cepillado.



2747

∅ 61 x 61

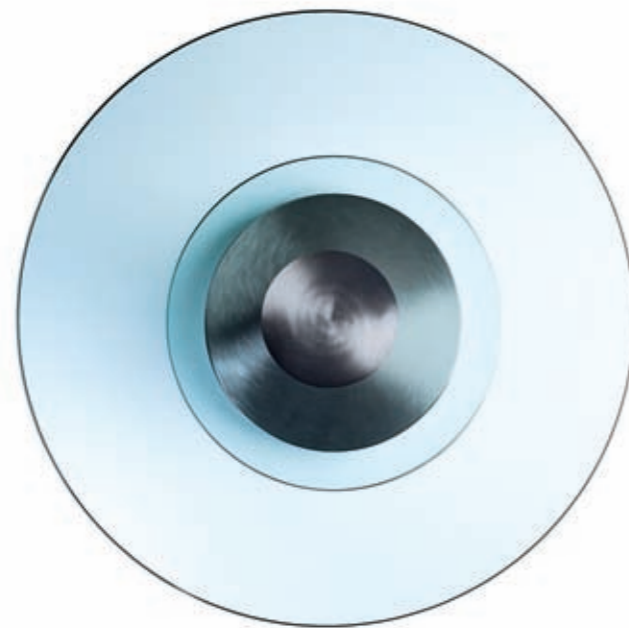

Tavolo con Ruote

Gae Aulenti 1980

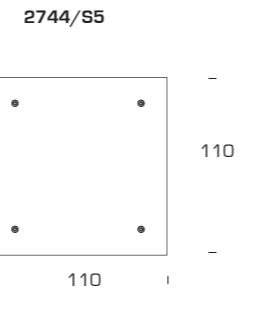
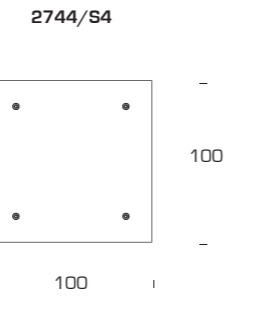
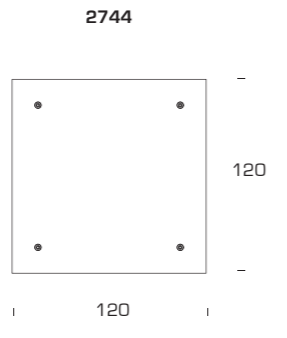
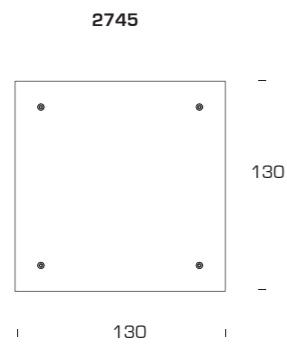
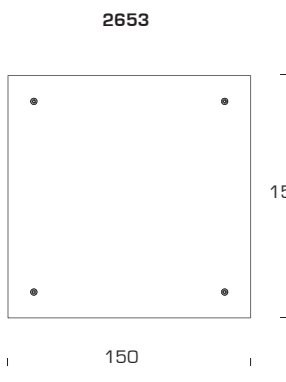
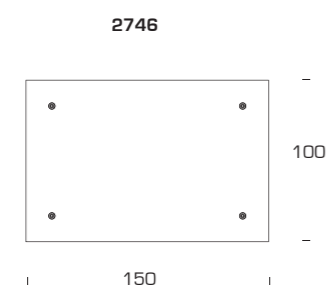
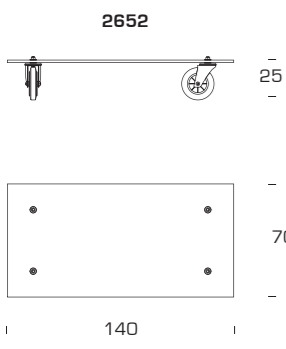

Tavolino. Piano in vetro float molato dello spessore di 15 mm. Ruote industriali con forcelle in metallo verniciato nero ottico.

Coffee table. Float ground-glass top (15 mm thick). Industrial wheels with black-painted metal brackets.

Table basse. Plateau en verre float biseauté (épaisseur 15 mm). Roulettes industrielles avec fourches en métal verni noir optique.

Kleiner Tisch. Oberfläche aus geschliffenem Float-Glas (15 mm stark). Industrieräder mit Gabeln aus optischem schwarzem lackiertem Metall.

Mesa baja. Sobre de cristal float biselado (espesor 15 mm). Ruedas industriales con horquillas de metal pintado negro óptico.

2652	140 x 70 x 25
2653	150 x 150 x 25
2744	120 x 120 x 25
2745	130 x 130 x 25
2746	150 x 100 x 25
2744/S4	100 x 100 x 25
2744/S5	110 x 110 x 25

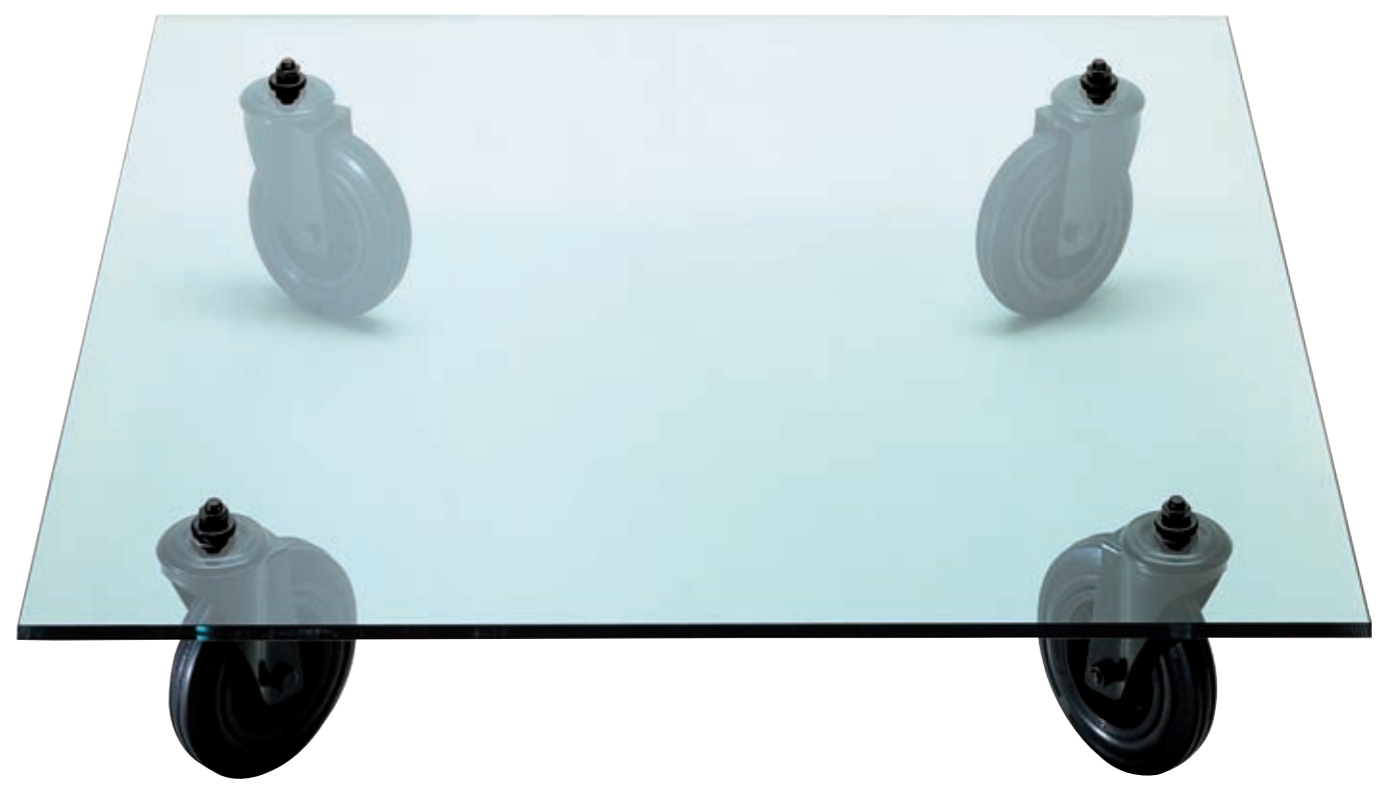

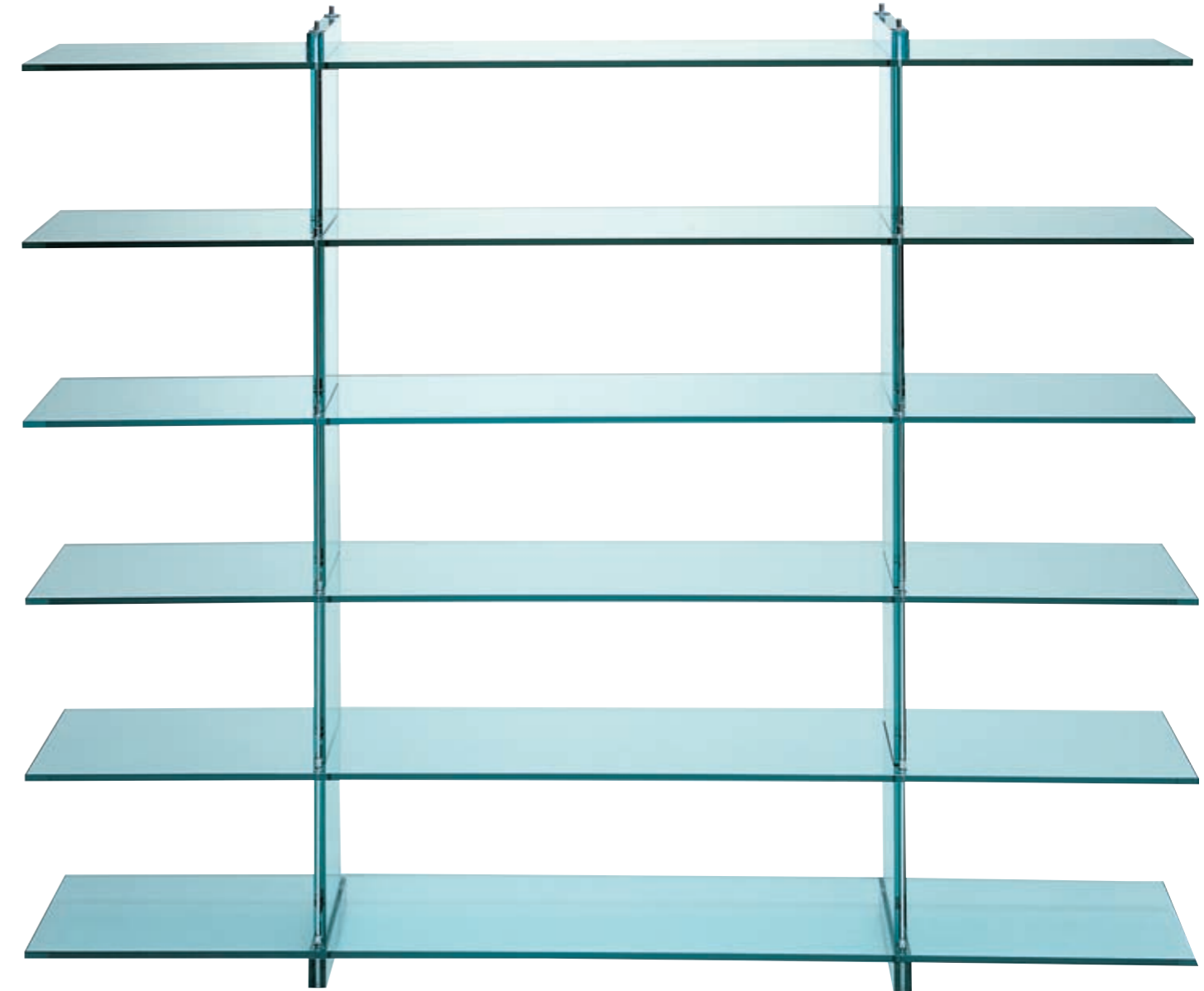
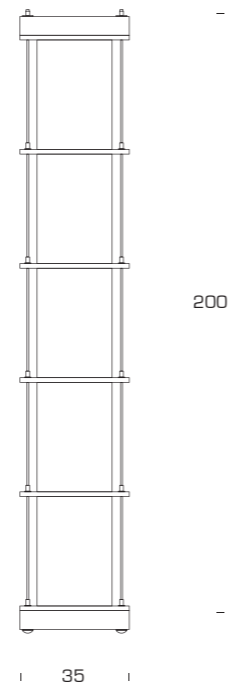
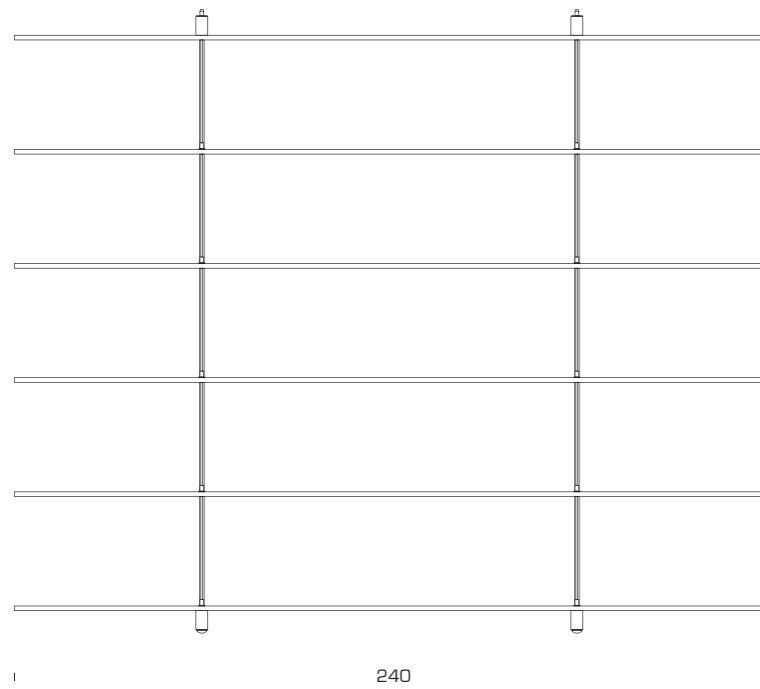

Libreria aperta sui due lati. Ripiani e montanti in vetro float dello spessore rispettivamente di 15 mm e 25 mm. Tiranti in metallo cromato. La tensione, grazie all'elevato coefficiente di compressione del vetro, trasforma la libreria in un monoblocco.

Bookcase open on two fronts. Shelves and uprights made of respectively 15 mm and 25 mm thick float-glass. Chromed metal ties. Due to the high-compression coefficient, the tension makes the bookcase a single block.

Bibliothèque ouverte sur deux fronts. Étagères (épaisseur 15 mm) et montants (épaisseur 25 mm) en verre float. Tirants en métal chromé. Grâce au coefficient de compression élevé du verre, la tension transforme l'ensemble en un monobloc.

Auf beiden Seiten offenes Bücherregal. Fächer und Pfosten aus Float-Glas 15mm bzw. 25mm hoch. Spannstangen aus verchromten Metall. Dank des hohen Kompressionskoeffizienten, wird aus dem Bücherregal ein einziger Glasblock.

Estantería abierta en dos frentes. Estantes y montantes de cristal float (espesor en respectivo 15 mm y 25 mm). Tirantes de metal cromado. La tensión, debido al importante coeficiente de compresión del cristal, transforma la estantería en un sólo bloque.

2757/6

240 x 35 x 200



Teso

Renzo Piano 1991

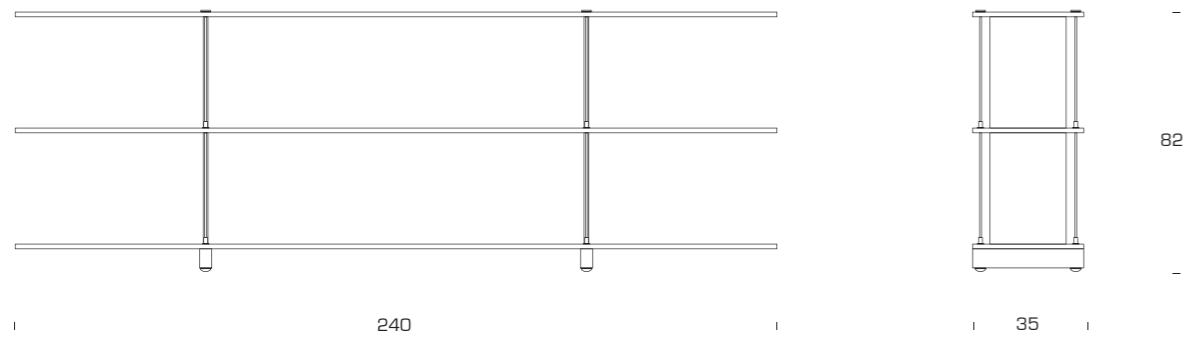

Consolle aperta sui due lati. Ripiani e montanti in vetro float dello spessore rispettivamente di 15 mm e 25 mm. Tiranti in metallo cromato. La tensione, grazie all'elevato coefficiente di compressione del vetro, trasforma la consolle in un monoblocco.

Console open on two fronts. Shelves and uprights made of respectively 15 mm and 25 mm thick float-glass. Due to the high-compression coefficient, the tension makes the console a single block.

Console ouverte sur deux fronts. Étagères (épaisseur 15 mm) et montants (épaisseur 25 mm) en verre float. Tirants en métal chromé. Grâce au coefficient de compression élevé du verre, la tension transforme l'ensemble en un monobloc.

Auf beiden Seiten offenes Regal. Fächer und Pfosten aus Float-Glas 15mm bzw. 25mm hoch. Spannstangen aus verchromten Metall. Dank des hohen Kompressionskoeffizienten, wird aus dem Regal ein einziger Glasblock.

Consola abierta en dos frentes. Estantes y montantes de cristal float (espesor en respectivo 15 mm y 25 mm). Tirantes de metal cromado. La tensión, debido al importante coeficiente de compresión del cristal, transforma la consola en un sólo bloque.

2842 240 x 35 x 82



Aixo Mateix

Valérie Bergeron 1994



Appendiabiti da parete con struttura in acciaio armonico. Sfere in vetro blu cobalto (BC), rosso rubino (R), verde (V) o trasparente (TR).

Wall coat hook with frame in harmonic steel. Spheres in cobalt blue (BC), ruby red (R), green (V) or transparent (TR) glass.

Portemanteau mural, structure en acier harmonique. Sphères en verre bleu cobalt (BC), rouge rubis (R), vert (V) ou transparent (TR).

Kleiderständern it Struktur aus harmonischem Stahl. Kugeln aus kobaltblauem (BC), rubinrotem (R), grünem (V) oder transparentem (TR) Glas.

Colgador de pared con estructura de acero armónico. Esferas de cristal azul cobalto (BC), rojo rubí (R), verde (V) o transparente (TR).



3037..BC - R - V - TR 7 x 9 x 7

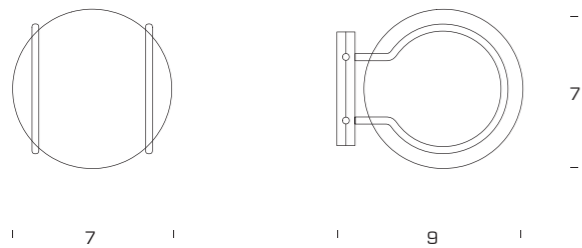

Bowl

Paolo Ulian 2003



Portaoggetti
appendibiti in vetro
soffiato trasparente.
Gancio supplementare
per appendibiti in metallo
cromato.

Holder and coat-hook.
Blown transparent glass.
Additional hook for
coat-stand in chrome-
plated metal.

Portemanteau et
porte-objets en verre
soufflé transparent.
Crochet supplémentaire
pour portemanteau en
métal chromé.

Kleiderständeru nd
Objektablage aus
mundgeblasenem Glas,
transparent. Zusätzlicher
Haken für Kleiderständer
aus verchromtem Metall.

Porta-objetos y colgador
de cristal soplado
transparente. Gancho
suplementario para
colgador de metal
cromado.

3411

19 x 12 x 22

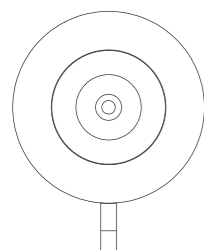

19

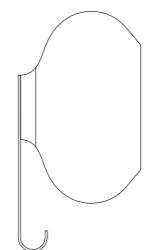

12

22

Cartoccio

Pietro Chiesa 1932



Vaso in vetro naturale (VN), satinato (VS) o stampato (VST). Colori per le versioni in vetro naturale o satinato: bianco (BI), blu (BL), giallo (GI), grigio (G), verde (VE). La lavorazione manuale del vetro rende il vaso unico e diverso da ogni altro.

Vase in clear (VN), satin (VS) or stamped patterned (VST) glass. Colours for the clear or satin glass version: blue (BL), white (BI), yellow (GI), grey (G), green (VE). The hand-crafted production of glass makes each vase unique and different from another.

Vase en verre naturel (VN), satiné (VS) ou imprimé (VST). Couleurs pour les versions en verre naturel ou satiné: bleu (BL), blanc (BI), jaune (GI), gris (G), vert (VE). Le travail à la main du verre rend le vase unique et différent de tous les autres.

Vase aus natürlichem Glas (VN), satiniert (VS) oder dekoriert (VST). Farben für die Versionen aus natürlichem oder satiniertem Glas: weiß (BI), blau (BL), gelb (GI), grau (G) und grün (VE). Das durch Handarbeit hergestellte Glas macht aus jeder Vase ein Einzelstück, jedes anders als das andere.

Jarrón en cristal natural (VN), satinado (VS) o estampado (VST). Colores para la versión de cristal natural o satinado: azul (BL), blanco (BI), amarillo (GI), gris (G), verde (VE). La elaboración manual del vidrio hace que el jarrón sea único y diferente a los demás.

2029/OVS - 2029/OVST	h. 15	
2029/OVN/.. - 2029/OVS/..	h. 15	BI - BL - G - GI - V
2029VS - 2029VST	h. 20	
2029VN/.. - 2029VS/..	h. 20	BI - BL - G - GI - V
2029/1VS - 2029/1VST	h. 30	
2029/1VN/.. - 2029/1VS/..	h. 30	BI - BL - G - GI - V

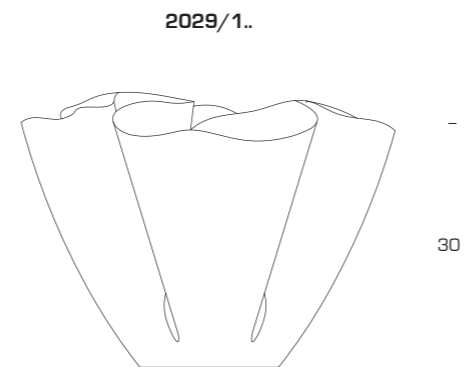
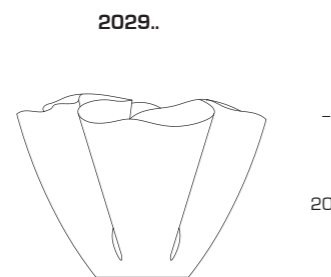
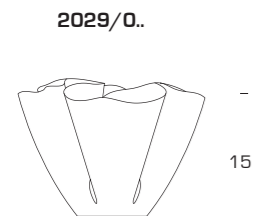

Vetro satinato / satin glass / verre satiné / satiniertes Glas / vidrio satinado



2029/OVS



2029VS



2029/1VS



2029/OVS/BI



2029VS/BI



2029/1VS/BI



2029/OVS/BL



2029VS/BL



2029/1VS/BL



2029/OVS/GI



2029VS/GI



2029/1VS/GI



2029/OVS/G



2029VS/G



2029/1VS/G



2029/OVS/V



2029VS/V



2029/1VS/V



2029/OVST



2029VST



2029/1VST

Vetro naturale / natural glass / verre naturel / natürliches Glas / vidrio natural



2029/OVN/BI



2029VN/BI



2029/1VN/BI



2029/OVN/BL



2029VN/BL



2029/1VN/BL



2029/OVN/GI



2029VN/GI



2029/1VN/GI



2029/OVN/G



2029VN/G



2029/1VN/G



2029/OVN/V



2029VN/V



2029/1VN/V

Cartoccio

Pietro Chiesa 1932

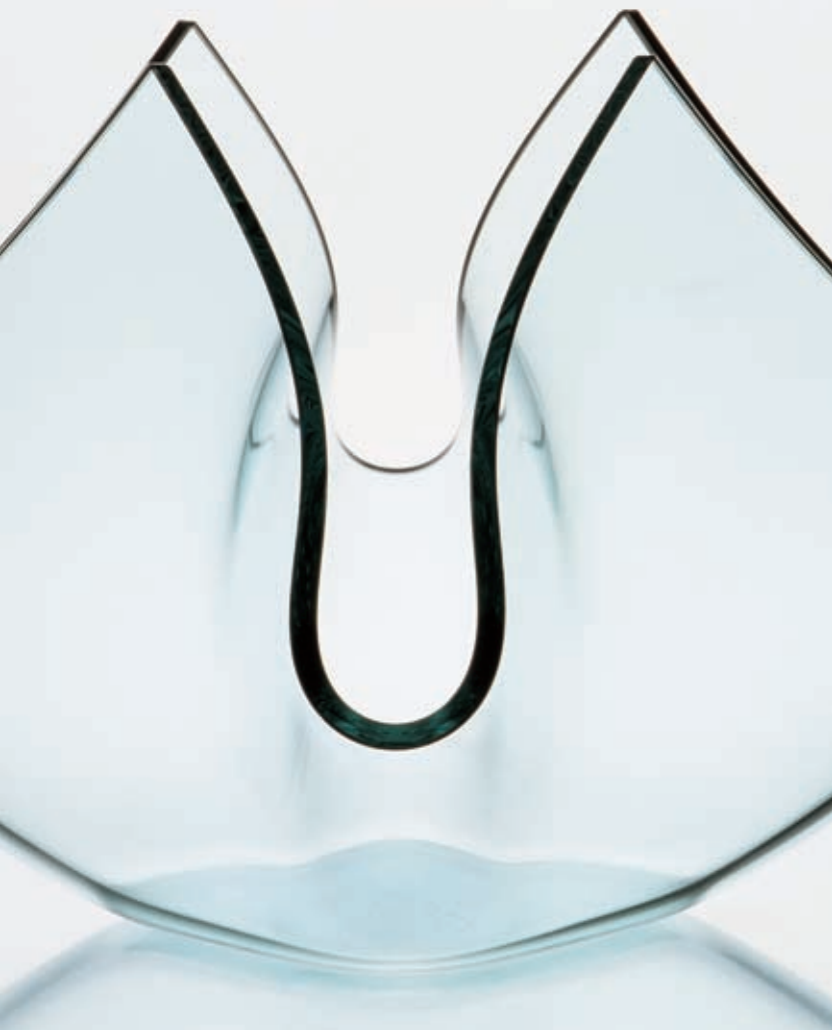

Vaso in vetro trasparente. Vase in clear glass.

Vase en verre transparent.

Vase aus transparentem Glas.

Jarrón de cristal transparente.

2029Q

h. 28

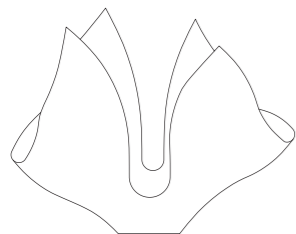

28